

CUSTOMER NAME	
CUSTOMER CONTACT	
CUSTOMER REFERENCE	

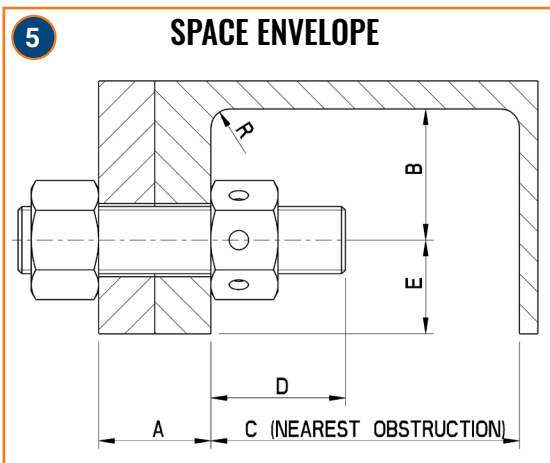
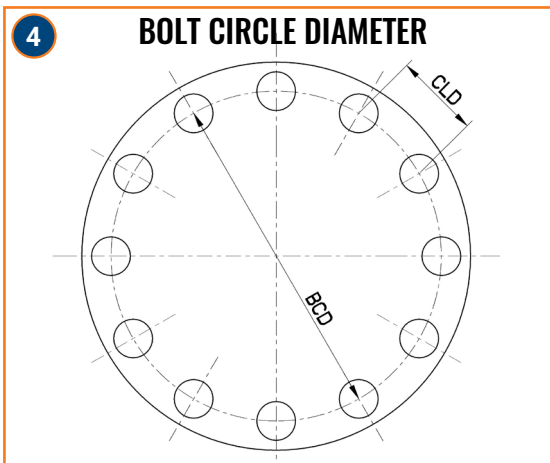
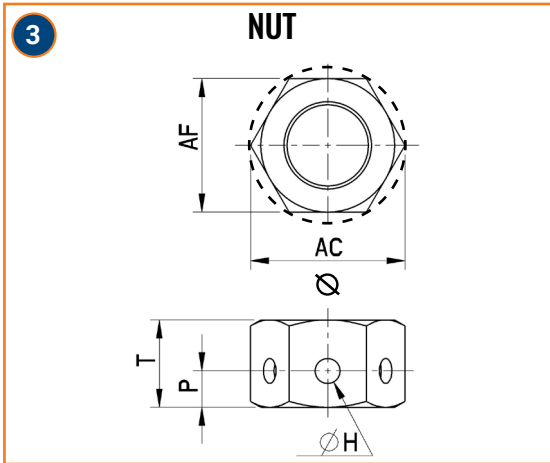

CRITICAL JOINT DATA

1 BOLT DATA

Bolt Thread Size & Pitch:	
Bolt Material:	

2 LOAD DATA

Required Load:	<input type="checkbox"/> Residual	<input type="checkbox"/> Applied	<input type="checkbox"/> Tool
Load:	<input type="checkbox"/> kN	<input type="checkbox"/> LBF	

3 NUT DATA

Nut Type:	<input type="checkbox"/> Round	<input type="checkbox"/> Hex	<input type="checkbox"/> Drilled	<input type="checkbox"/> Other (Provide Details below)
Nut AF:	Nut AC/ \varnothing			
Nut Height:				
Hole \varnothing	P:			
No Holes:	Other:			

4 BOLT SPACING

Number of Bolts:	
BCD _____ or CLD _____	

5 SPACE ENVELOPE

A	B
C	D
E	R

ADDITIONAL CONSIDERATIONS: (PROVIDE DETAIL SEPARATELY)

- | | | | |
|---|---|--------------------------------------|--------------------------------------|
| <input type="checkbox"/> Frequency of use | <input type="checkbox"/> Additional Tool Features | <input type="checkbox"/> Washer | <input type="checkbox"/> Environment |
| <input type="checkbox"/> Spot Face | <input type="checkbox"/> Castellated/Flat Nut | <input type="checkbox"/> Orientation | <input type="checkbox"/> Temperature |
| <input type="checkbox"/> Handling | <input type="checkbox"/> Other | | |