

DIMENSION SHEET

STEPPED PIN – TYPE C



ENGLISH

Company: _____ Contact person: _____
 City / State: _____ Phone: _____
 Country: _____ Fax: _____ Email: _____
 Order Inquiry Quantity: _____ pcs Measured by: _____
 Machine make & model: _____ Machine year: _____
 Machine Serial No: _____ Original pin part number: _____
 Pin location on machine: _____

PIVOT DIMENSION ORIGINAL PIN SOLUTION

Measurements in: Inches mm

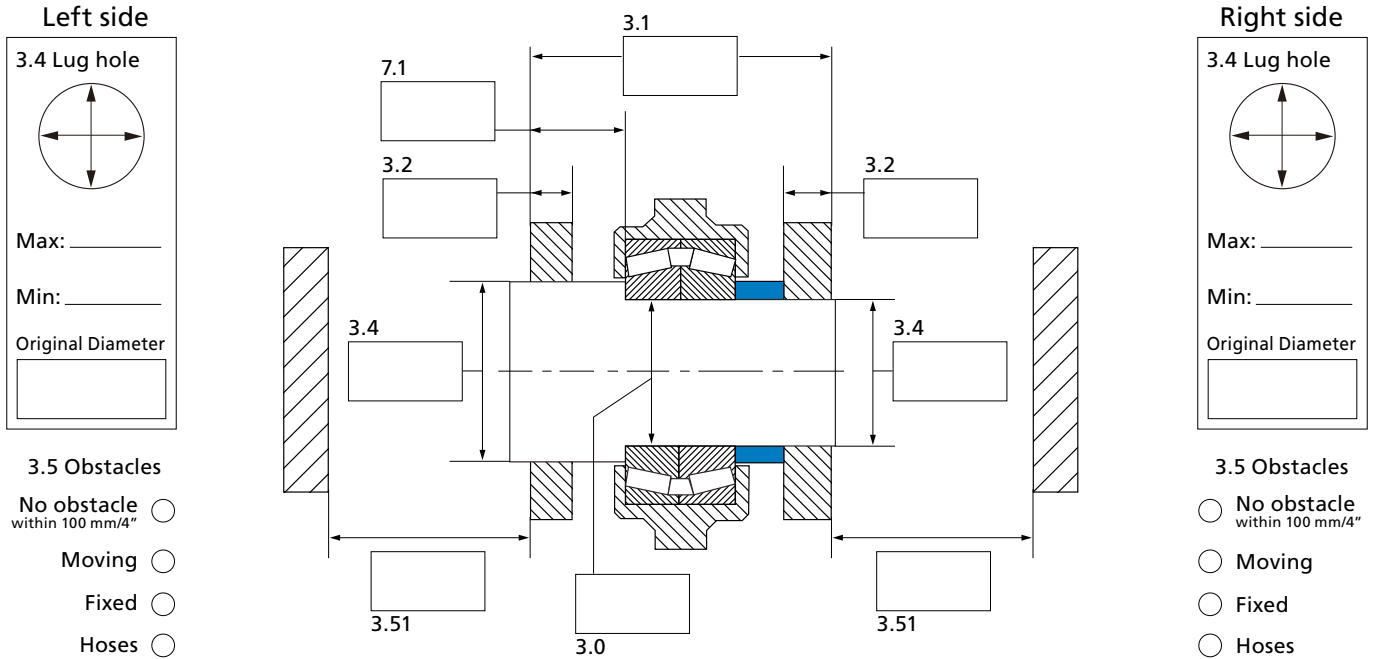

GREASING

EXPANDER SYSTEM SOLUTION

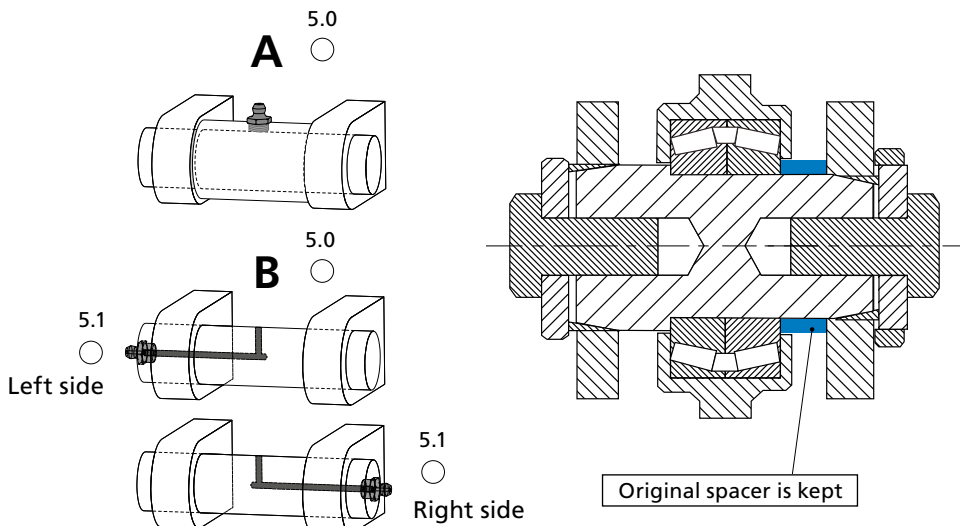

Any questions? Contact:
Expander System Americas
 Phone (toll free): +1 888 935-3884
Expander System Sweden
 Phone: +46 (0)120-299 00

www.expandersystem.com
www.nord-lock.com

DIMENSION SHEET

STEPPED PIN – TYPE C



PIVOT DIMENSION ORIGINAL PIN SOLUTION

- 3.0 Original pin diameter. The diameter is usually an standard axle diameter.
As a service Expander System helps to choose a suitable tolerance for the application.
- 3.1 Measure the distance between the outside edges of the mounting lugs.
Measuring accuracy +/- 1 mm (+/- 0,04").
- 3.2 Measure the width of respective mounting lug. Measuring accuracy +/- 1 mm (+/- 0,04").
- 3.4 Fill in the original diameters of the holes of the mounting lugs (bushings removed if applicable). If the holes are more than 1,5 mm (0,06") worn measure the maximum and minimum diameters of the worn holes. Measuring accuracy +/- 0,2 mm (+/- 0,008").
- 3.5 If there are obstacles within 100 mm (4") from the outside of respective mounting lug, indicate type of obstacle (moving, fixed or hoses).
- 3.51 If obstacles indicated in 3.5, measure the distance between respective outside edge of mounting lug and obstacle. Measuring accuracy +/- 1 mm (+/- 0,04").
- 7.1 Measure the distance between outside edge of mounting lug and contact surface of the connected bearing. Measuring accuracy +/- 1 mm (+/- 0,04").

GREASING

- 5.0 Indicate the grease distribution of the pivot. A=external greasing, B=greasing through pin (one outlet centred between the inner edges of the lugs).
- 5.1 If B, indicate from which side the pivot is greased.



Press this icon to **CLEAR** the pivot dimension sheet.



Press this icon to **PRINT** the pivot dimension sheet.



For straight pins, please use the dimension sheet for straight pins.