

# OPERATORS MANUAL



## MOORE UNIDRILL MDH-1700

April 2024, Serial No. 8787 and onwards



---

### MOORE UNIDRILL (MANUFACTURING) LTD

RANDALLS FARM, SCOTTLETHORPE ROAD, EDENHAM, BOURNE, LINCS, PE10 0LN

+44 (0) 28 2766 4444  
reception@moore-unidrill.com  
www.moore-unidrill.com

# Foreword

Please read and observe these instructions very carefully before you proceed to operate the seed drill. This way you will avoid accidents, reduce repair costs and downtime, and increase the reliability and service life of your seed drill. Pay particular attention to the safety instructions. Moore Unidrill Manufacturing Ltd cannot assume any liability for damage or malfunctions caused by a failure to observe the instructions contained in this operating manual.

The purpose of this operating manual is to enable you to familiarize yourself with the working of your seed drill and to make full use of the many possibilities of application which it affords. The manual will first explain the seed drill in general and then proceed to describe the special features of the different models.

The terms "right", "left", "front" and "back" are used here for when sitting in the tractor seat looking forward. This operating manual must be read and used by all persons who are required to carry out work either on or with the seed drill, e.g., Operation, Maintenance, Transporting.

On our website [www.moore-unidrill.com](http://www.moore-unidrill.com) you will find a link to a "Warranty Registration Form". Once you have familiarised yourself with this operation manual, please complete the registration form via our website. This will confirm your acquisition of the seed drill. The period of guarantee commences on the date of delivery.

Moore Unidrill Manufacturing Ltd reserve the right to make changes to the illustrations and data on specifications and weights contained in this operating manual if we make any improvements to the seed drills.

## Seed drill identification

Once you have accepted delivery of the seed drill, please enter the following data:

Serial No: .....  
Seed drill model: .....  
Working width: .....  
Number of coulters: .....  
Accessories: .....

Date of issue of Operators Manual: April 2024

# Contents

<b>Guarantee Guidelines</b>	<b>4</b>
<b>Safety instructions</b>	<b>4</b>
<b>Proper Use</b>	<b>5</b>
<b>Operational Safety</b>	<b>6</b>
<b>No liability for consequential damage</b>	<b>6</b>
<b>Road Safety</b>	<b>7</b>
<b>Accident Prevention</b>	<b>7</b>
<b>Coupling the seed drill to the tractor</b>	<b>7</b>
<b>Using the hydraulic system</b>	<b>8</b>
<b>Operating the seed drill</b>	<b>8</b>
<b>Care and maintenance</b>	<b>9</b>
<b>Description &amp; Technical detail</b>	<b>10</b>
<b>Setting up and using the seed drill</b>	<b>11</b>
<b>Road Transport</b>	<b>11</b>
<b>Coupling the seed drill to the tractor</b>	<b>11</b>
<b>Setting the sowing depth</b>	<b>12</b>
<b>Calibration and sowing</b>	<b>13</b>
<b>Setting the seed rate</b>	<b>13</b>
<b>Changing the metering system from normal to fine seed</b>	<b>14-16</b>
<b>Calibration test</b>	<b>17-20</b>
<b>Hydraulic drive fan</b>	<b>20-22</b>
<b>Care &amp; Maintenance</b>	<b>23</b>
<b>Packer Roller</b>	<b>23</b>
<b>Nuts &amp; Bolts</b>	<b>23</b>
<b>Seed tube/coulter adjustment</b>	<b>23</b>
<b>Daily maintenance</b>	<b>24</b>
<b>Emptying the hopper and metering system</b>	<b>24</b>
<b>Dampness</b>	<b>25</b>
<b>Storage and post season</b>	<b>25</b>
<b>Wearing parts</b>	<b>26</b>
<b>Parts list of common serviceable components</b>	<b>27-28</b>
<b>Moore Unidrill techniques</b>	<b>29-32</b>
<b>EU Declaration and conformity</b>	<b>33</b>
<b>Trailed Drill Supplement</b>	<b>34-35</b>

# Guarantee Guidelines

1. Our products are guaranteed [for a period of 12 months commencing on the date of delivery to the user. The guarantee does not cover the replacement of parts subject to wear.
2. Guarantee claims must be submitted to Moore Unidrill Manufacturing Ltd product support team. Claims cannot be considered unless the claim form has been completed in full and submitted no later than 3 months after occurrence of the damage or defect giving rise to the guarantee claim.
3. Parts replaced under the terms of the guarantee will first of all be charged to the customer pending a decision by Moore Unidrill Manufacturing Ltd product support team as to whether or not the guarantee claim is justified. Faulty parts must therefore be returned to our workshop for inspection.
4. Once the guarantee claim has been acknowledged, a credit note will be issued on the basis of prices ruling on the date on which the guarantee claim was received and in accordance with Moore Unidrill Manufacturing Ltd general terms of delivery and payment.

## Safety instructions

Please read all safety instructions contained in this operating manual with the utmost care and observe all warning signs attached to the seed drill. These warning signs must be kept in a legible condition and must be replaced if missing or damaged. This is especially the case when whole sections are replaced when making repairs.

Follow these instructions to prevent accidents. These instructions must also be made available to all other users. You are advised to refrain from any working methods which may be hazardous.

## Proper use

Moore Unidrill seed drills are based on state-of-the-art technology and are manufactured in accordance with recognized safety requirements. Nevertheless, the use of these seed drills does not preclude the risk of injury to the user or third parties and/or the risk of damage to the seed drill itself or to other materials or items of equipment.

Always make sure that the seed drill is in a technically perfect condition and that it is used properly and for its intended purpose and entirely in accordance with the instructions given in this manual. Any malfunctions or defects which might affect the safe operation of the seed drill must be immediately rectified.

The seed drill may be used, maintained, and repaired only by persons who are familiar with its working and have been made fully conversant with the risks involved.

OEM replacement parts and accessories from Moore Unidrill have been specially designed for use with Moore Unidrill drills. Any replacement parts and accessories not supplied by Moore Unidrill have not been tested or approved by us. The installation and/or the use of non-genuine Moore Unidrill parts may under certain circumstances have a negative influence on the given design features of your seed drill and may therefore adversely affect its safe and reliable operation and your safety.

Moore Unidrill cannot be held liable for damage or injury caused by the use of non-genuine replacement parts or accessories.

Moore Unidrill seed drills are intended for seeding (sowing). Any uses other than those for which the seed drills are intended, such as transportation, will automatically exempt the supplier from its / their Moore Unidrill liability in respect of ensuing damage. Such cases of improper use will therefore be entirely at the user's own risk.

All relevant accident prevention regulations, as well as other generally acknowledged safety and health regulations and road traffic regulations, must be strictly observed.

Improper use also comprises failure to observe the instructions given in this operating manual and the manufacturer's maintenance and servicing requirements.

## Operational safety

The seed drill must not be put into operation until the user has been given proper initial instruction either by the dealer or by one of Moore Unidrill Manufacturing Ltd representatives or employees. All warranty registration forms are to be completed via the Moore Unidrill website [www.moore-unidrill.com](http://www.moore-unidrill.com)

The seed drill may be used only if all safety devices, such as detachable guards are fitted and in proper working order.

Nuts and bolts should be checked at regular intervals and tightened if necessary.

Tyre pressures must also be checked regularly (trailed models only)

In the event of a malfunction, immediately cease operation and secure the seed drill in its stationary position. Malfunctions must be eliminated immediately.

## No liability for consequential damage

Even though your Moore Unidrill seed drill has been manufactured with the utmost care and you are using it properly. Fluctuations and interruptions in seed delivery may still occur, the possible causes being:

- differences in composition of the seed or fertilizer (grain size, density, shape, dressing, treatment)
- clogging or bridging (e.g., through foreign bodies, glumaceous seed, sticky dressing agents, moist fertilizers)
- worn parts (e.g., metering device, v-belt)
- damage through external influences
- incorrect drive speeds and forward speeds
- incorrect setting of seed drill (wrongly mounted, failure to observe calibration charts)
- incorrect connection or operation of the electronic seed drill drive or an error in the tractor's electric installation.

It is therefore advisable, both before and during use, to check that the seed drill is functioning properly and delivering the seed with the required accuracy. Such deviations in the delivery rate are only partially detectable by the electronic seed drill control and the monitor of the electronic seed drill drive.

Any claims for damages not directly incurred by the seed drill cannot be accepted. Moore Unidrill cannot be held liable for any consequential damage resulting from incorrect metering or distribution.

## Road safety

Road traffic regulations must be observed when towing the seed drill on roads, paths, and other public places. The seed drill must be in a roadworthy condition.

Observe the maximum permissible width for road transport and fit all necessary rear lights, warning signs and guards. Disconnect the electrical supply when fitting.

Fold up the side sections, track markers, etc. and secure them in the transport position. When transporting the seed drill on the road, lock the control valve in the tractor cabin to prevent the coulter bar from being opened out accidentally. In addition, close the ball valve in the hydraulic hose.

Trip ropes for quick-release couplings must hang loose and must not, when in their lowered position, release the couplings of their own accord.

Observe maximum permissible axle loads, the load-bearing capacity of the tyres and the maximum total weights to ensure adequate steering and braking. The behaviour of the tractor is also influenced by attached implements. Take the width and balancing weight of the seed drill into consideration, especially on sharp bends.

No persons may be allowed to ride on or in the seed drill.

## Accident prevention

Care must be paid not only to the safety instructions contained in this operating manual but also to 'the accident prevention regulations governing the operation of agricultural machinery'

## Coupling the seed drill to the tractor

The act of coupling and uncoupling the seed drill (using the three-point linkage) involves a high risk of injury. The following instructions must therefore be carefully observed:

- Secure the tractor in such a way that it cannot roll forwards or backwards.
- Slowly and carefully work the three-point linkage power lift system.
- Be extremely careful when working with a three-point linkage.
- Position the seed drill with its support legs on firm, level ground.

The tractor and the seed drill must be equipped with the same category of three-point linkage.

## **Using the hydraulic system**

Do not connect the hydraulic hoses to the tractor's hydraulic system until you have made sure that the system is at zero pressure on both the tractor and the equipment side.

The hydraulic system generates extremely high pressures. All piping, hoses and connections must therefore be checked regularly for leakage and visible external damage. Use a proper and thorough means of searching for leakage and repair all damage immediately. Spurting hydraulic oil can cause injuries and fires. Call a doctor immediately in the event of injury.

To exclude the possibility of incorrect connection, all mating plugs and sockets belonging to the hydraulic connections between the tractor and the seed drill should be marked with matching colours. Ensure hydraulic fittings are clean and free of grit / dirt that could cause damage.

## **Operating the seed drill**

Prior to start-up and operation, make sure that nobody is standing in dangerous proximity to the seed drill.

No persons may ride on the seed drill during operation.

None of the prescribed guards supplied with the seed drill may be removed during operation.

# Care and maintenance

Observe all maintenance check interval guidelines and inspections.

Before carrying out any care or maintenance work, always de-pressurize the hydraulic system and the tractor engine. Uncouple the seed drill from the tractor.

Make sure, prior to carrying out any care or maintenance work on the drill, that the seed drill is standing on firm, level ground and cannot roll away or tip over (use the parking stands supplied). Use the steps provided for access to the drill, do not use parts of the frame.

When cleaning down the drill, ensure any electrics are covered to avoid water damage.

All hydraulic lines must be checked for leakage, looseness, abrasion, and damage. All defects and damage must be immediately rectified.

Prior to carrying out maintenance and repair work on the electrical system, disconnect it from the power supply.

When carrying out any welding on the seed drill, disconnect the drill fully from the tractor.

All screw connections which had been slackened or unscrewed for maintenance and repair purposes must be refitted and properly tightened.

## Description and technical detail



1. Hopper Access Steps
2. Handrail
3. 1700L Hopper
4. Land Drive Wheel
5. LED Road Lights
6. Self-Cleaning Prism Packer Roller

# Setting up and using the seed drill

## Road transport

Fit warning signs and the necessary lighting and guards for road transport.

Make sure the seed hopper is empty before you proceed to transport your seed drill along the road.

The maximum speed at which the seed drill may be transported on the road is 25km/h.

Retract the land drive wheel and lock it in position.

Fold up the hopper access steps.

## Coupling the seed drill to the tractor

When coupling the seed drill to tractor, make sure there are no persons standing between the tractor and the seed drill.

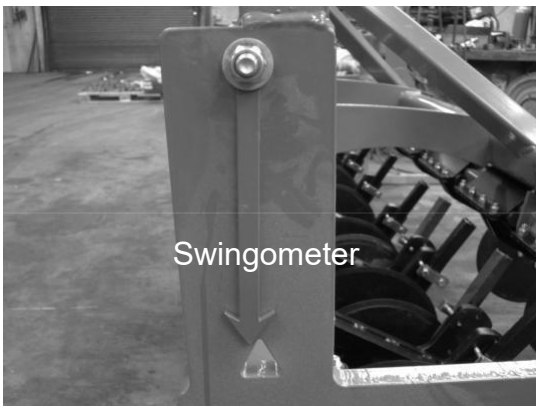

Set the tractors draft links in such a way that the seed drill can swing sideways only very slightly, and so that each arm can float independently, and allow the rear packer to control the seeding depth independently of the tractor. After hitching on to the lower links, raise the drill and fold up the parking stands, slide them inside the chassis and secure with the linch pins provided.

Lower the lower link arms and then attach the top link.

The top link should be positioned as high as possible on the tractor and as low as possible on the headstock so that the seed drill is as parallel as possible with the ground when raised.

On level ground, set the top link length so that the swingometer on the side of the drill points to the middle position, to indicate that the chassis is level, so that both front and rear discs will operate at the same depth.

In the field pull out the land drive wheel and secure with pins provided in working position. An adjustable stop can be used to set the downward limit of the drive wheel.

When unhitching the drill, fully extend the hydraulic packer rams so the machine is in its shallowest working position and the packer is carrying the weight of the drill. Set the drill down, and uncouple the top link first, then raise the drill, with the full weight on the rear packer, at this point pull out the parking stands, so that the hinge is just proud of the chassis, unfold them, and gently lower the drill onto the stands, making sure the hinge mechanism has engaged properly on both sides until they have taken the remaining weight, at which point, uncouple the lower link arms.

**Failure to follow this procedure will cause damage to the hinge mechanism on the parking stands.**

## **Setting the sowing depth**

The sowing depth can be adapted to the soil conditions by adjusting the coulter pressure.

This is done by adjusting the hydraulic packer depth control ram to the desired depth on the sliding depth sight gauge. The rear packer acts as a depth stop and can increase and decrease the amount of pressure on the discs.

In normal circumstances, in good moist conditions, very few of the removable ballast weights are required to achieve grass and small seeding depths, and so these 27kg weights, can be added and removed as required. Please observe HSE manual handling guidelines.

When the desired seeding depth is achieved, check that the front and rear coulters are sowing at the same depth, by re-adjusting the top link again, and keeping the swingometer in the central and therefore level position.

# Calibration and sowing operation

## Setting the seed rate

To obtain the desired seed rate, please refer to the seed rate calibration chart, which indicates the settings for medium to large seeds on the left-hand side and fine seeds on the right-hand side.

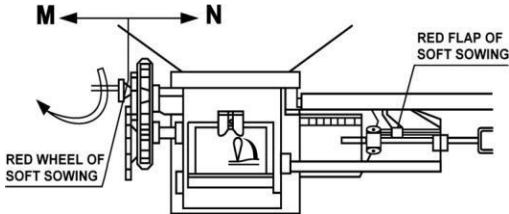
SEED RATE CHART																							
Type of seed:	Wheat	Rye	Barley	Oats	Beans	Fertilizer	Peas	Lupines	Vetches	Corn	Grass	Type of seed:	Rape	Red clover	Grass								
kg/dm <sup>3</sup>	0.77	0.74	0.68	0.5	0.85	1.03	0.81	0.76	0.83	0.79	0.36	kg/dm <sup>3</sup>	0.65	0.77	0.39								
Standard seeds Kg/ha												Fan opened -N-				Fine seeds Kg/ha				Fan ½ closed -F-			
Standard	10	34	33	32	24	23	39	21	28	32	8	Fine seeds	2.50	1.80	0.90	2.30	1.15						
	15	51	49	48	35	42	58	40	45	51	24		18	5.00	4.60	2.30	5.30	2.65					
	20	69	66	64	47	61	77	59	62	70	47		26	7.50	6.80	3.40	8.60	4.30	2.80	1.40			
	25	86	83	79	59	79	97	78	79	89	70		34	10.0	9.10	4.55	12.0	6.00	5.20	2.60			
	30	104	100	95	71	98	116	97	96	108	92		42	12.5	11.4	5.70	15.3	7.65	7.20	3.60			
	35	122	117	111	82	116	135	117	113	127	115		50	15.0	13.7	6.85	18.0	9.00	9.20	4.60			
	40	140	134	127	94	135	155	136	130	146	137			17.5	15.9	7.95	21.3	10.6	11.2	5.60			
	45	157	151	143	106	154	174	155	147	165	156			20.0	18.2	9.10	24.0	12.0	13.2	6.60			
	50	174	168	159	118	172	193	174	164	184	175			22.5	20.5	10.2	26.6	13.3	15.0	7.50			
	55	192	184	174	130	191	213	194	181	203	194			25.0	22.8	11.4	27.5	13.7	16.2	8.10			
	60	210	200	190	141	209	232	213	198	222	212				N	M	N	M	N	M			
	65	228	217	206	153	228	251	232	216	241	231												
	70	246	235	222	165	246	270	251	234	260	249			N = NORMAL      M = MICRO									
	75	264	252	238	177	265	290	270	251	279	267			<b>85 handle turns = 1/10 ha</b>									
80	281	269	253	189	283	309	289	268	298	285													
85	298	286	268	200	302	328	309	285	317	304													
90	316	302	284	212	320	348	328	302	336	323													
95	335	319	300	224	338	367	347	320	355	342													
100	352	337	316	236	356	386	366	337	374	361													
105	370	354	332	248	374	406	385	354	393	380													
110	387	371	348	260	393	425	404	371	412	398													

To determine the correct adjustment value, first specify whether the seeds are normal or fine:

- Normal seed: between 4 and 10 mm
- Fine seed: between 1.5 and 4 mm

The table contains orientation values for a variety of normal and fine seeds, and for various amounts of seed per hectare. These values are for orientation purposes only. Seed can vary regarding grainsize and relative density. Determine the exact adjustment value for your seeds by means of a calibration test.

## Changing the metering system from normal to fine seed

The micro metering system allows for the application of fine seed and small amounts of seed per hectare. The micro metering system is normally switched on at the factory.

To **Switch Off** - Push the red gearwheel into the grey gearwheel behind it until they mesh.

### Switch off

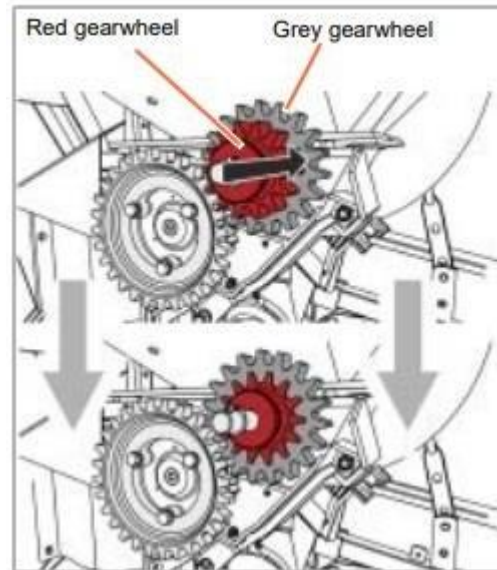

*Note: When inserted or pulled out, the gearwheels must align so that the red gearwheel can be easily pushed in or pulled out.*

To **Switch On** - Pull out the red gearwheel so that it engages with the front wheel.

### Switching on

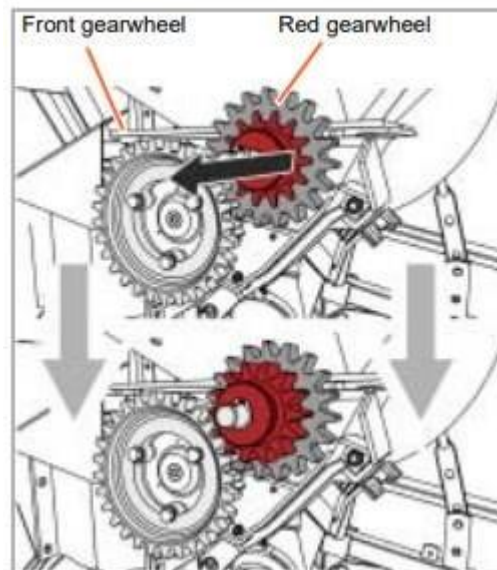

Using the crank, set the adjustment value for the desired seed type. Turn until the desired seed value appears at the edge of the housing.

□

The red changeover switch for setting either normal or fine seed is located on the hexagonal tube on the metering device.

## Normal seed

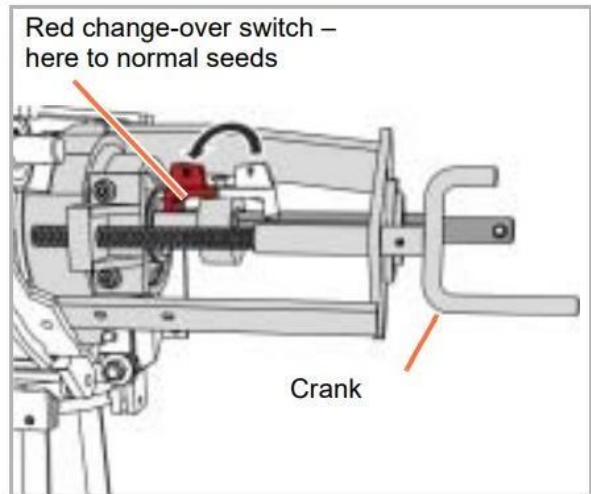

*Note: Only switch from normal to fine seed if the seed hopper is empty. Changing the setting when the seed hopper is full can destroy the metering device.*

## Fine seed

Now set the change-over switch on the metering device:

- Normal seed = Red change-over switch points towards the metering device.
- Fine seed = Red change-over switch must engage in the hexagonal shaft groove on the metering device and point away from the metering device.

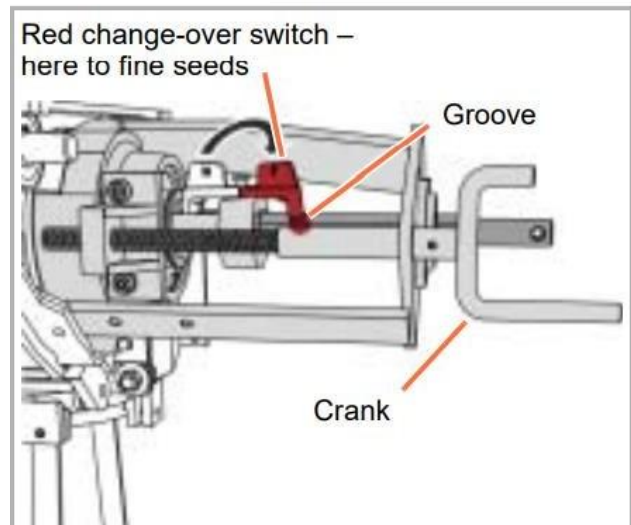

The **regulating flap** on the fan regulates the airflow for the seed. Set the regulating flap according to the seed type and weight.

- The illustration shows the flap set to "fine seed" as it is shut right down.
- Swivel the lever by 90° degrees in the direction of the arrow to change to "normal seed."
- Further fan pressure adjustment can be made using the regulating flaps on the y piecer splitter as shown in the image below.

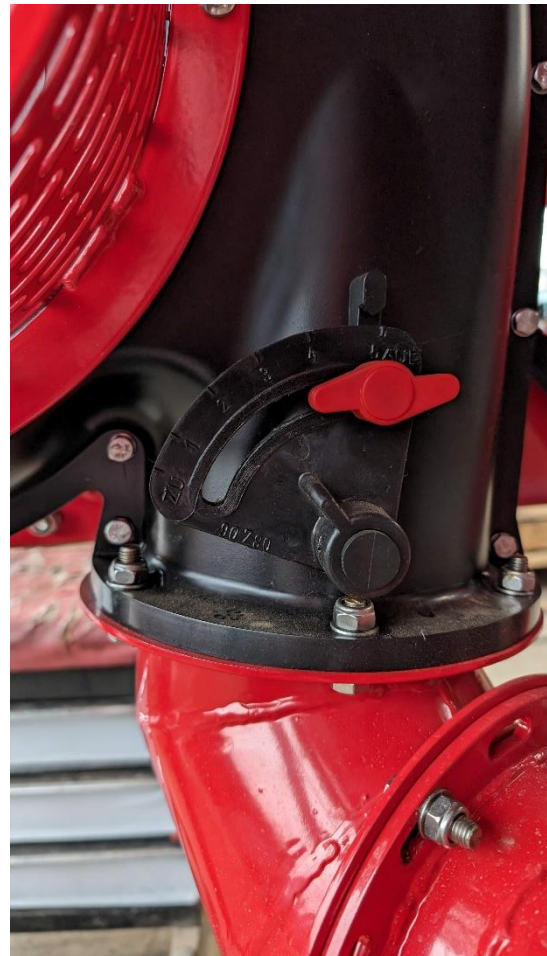

## Calibration test

The calibration test is usually performed on farm.

Before you can begin the calibration test:

- Close the emptying flap at the metering device.
- *Note: Check the seed hopper. Inspect the seed hopper for foreign bodies. Foreignbodies in the seed hopper can cause damage to the machine.*

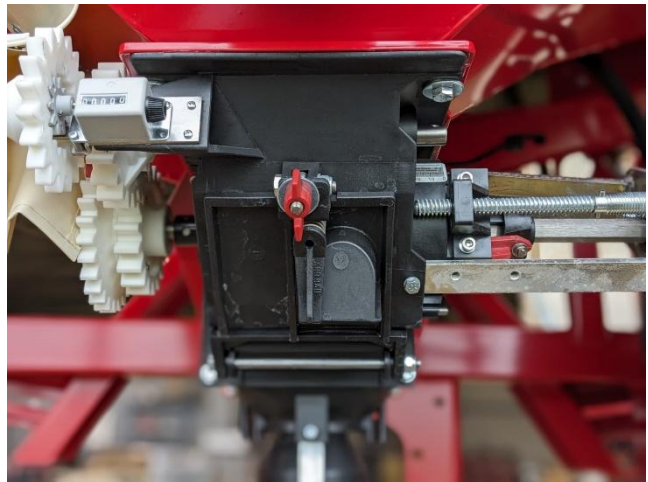
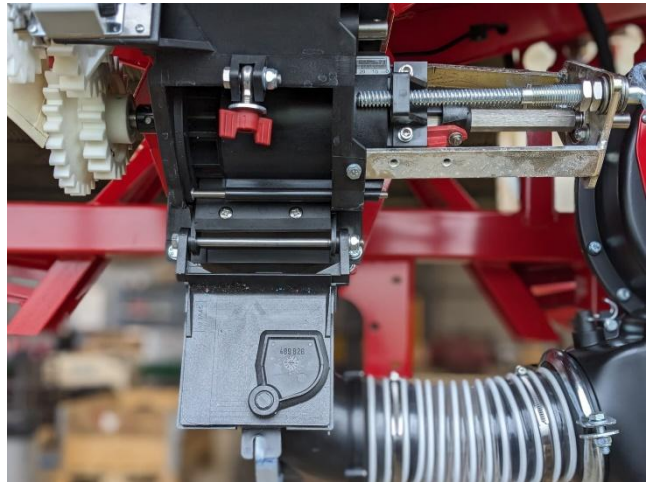

- Place the red change-over switch into the "fine" or "normal" seed position.

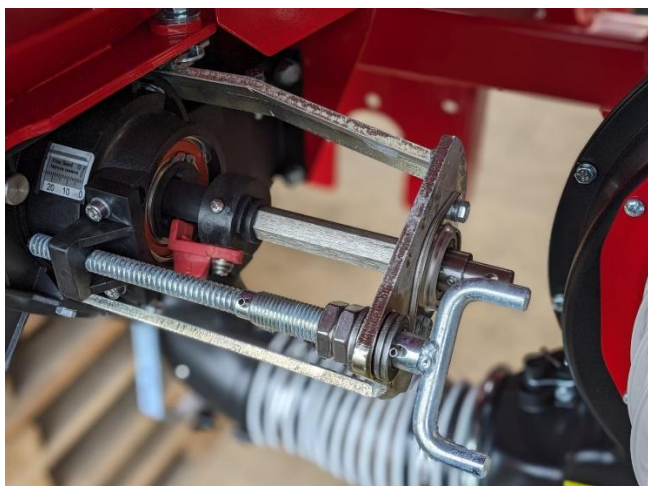

- Place a catch pan under the metering device (the catch pan must be large enough to hold the amount of seed generated during the calibration test)
- Release the bolt.
- Fold the bracket to the side.
- Remove the elbow.

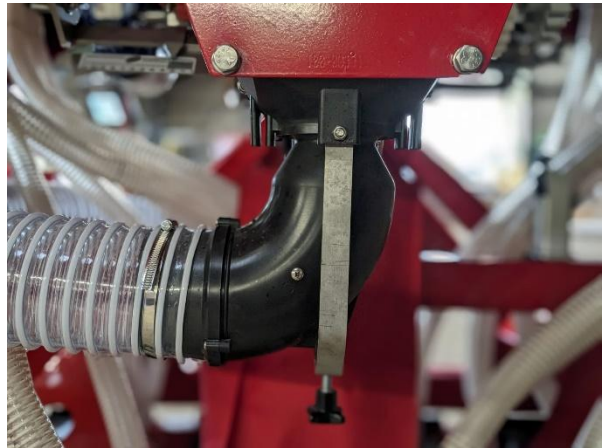

Read the adjustment value for normal or fine seed from the table on the seed hopper or in this manual (see page 14)

*Note: There must be no seed in the metering device if you are decreasing the cell width.*

- Using the crank, set this value on the metering device. Adjusting to this value changes the metering device cell width.
- Add sufficient seed to the seed hopper for the calibration test.



- *Note: This is the front tank metering device slider and handle*

- *Note: This is the rear tank metering device slider and handle*

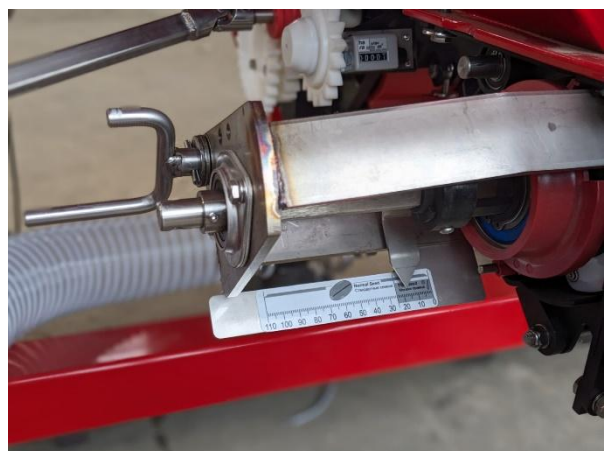

- Remove the calibration handle from its retainer.
- Pull the shaft off and mount the calibration handle on the shaft. Secure with a cotter pin.

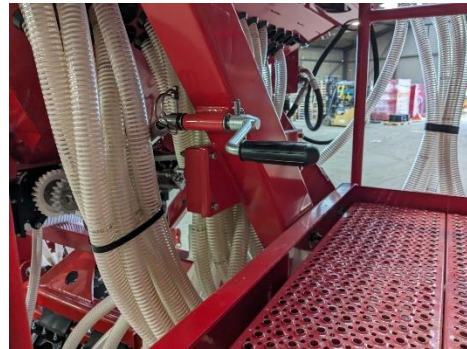

- *Note: On land wheel driven & GPS metered drills. Ensure rear tank drive shaft is disconnected before adjusting and setting up the front tank metering.*

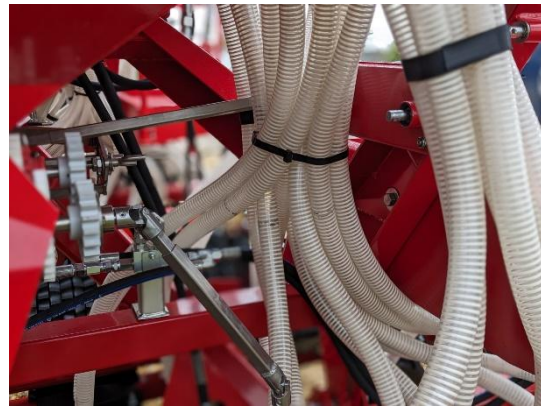

- If your machine is land wheel driven, place the calibration handle and calibration drive shaft onto this knuckle. Jump to Page 20 "Performing the calibration test"
- *Note: If your machine is electronically driven metering for the front tank, please follow the instructions that are listed clearly for this system in the back of the book*

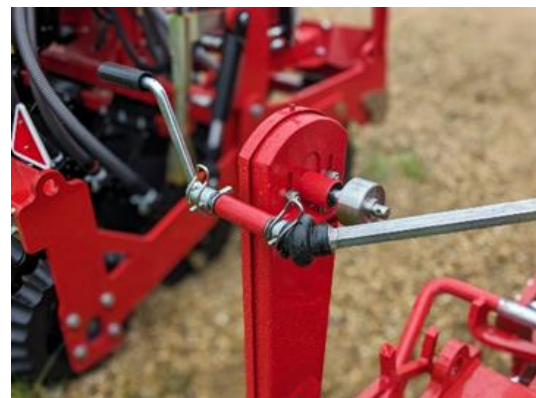

- Connect the rear tank drive shaft to this to calibrate the rear tank. Jump to Page 20 “Performing the calibration test”

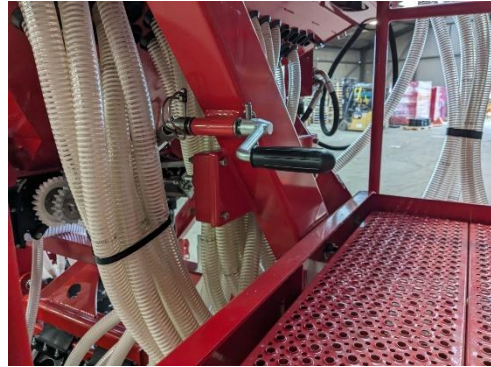

## Performing the calibration test

The seed metering system is now ready for the calibration test. Perform the calibration test according to the machine settings for normal or micro metering.

Select the speed at calibrating with the calibration handle to fit the later driving speed.

The calibration test is performed for 0.10 ha.

- Carry out 85 revolutions with the calibration handle mounted on the metering device.

## Evaluating the calibration test

- The calibrated quantity of seed represents the amount sown for 0.10 ha.
- We recommend performing the calibration test at 0.10 ha for seed quantities up to approximately 100 kg/ha, and at 0.05 ha for larger quantities. At 0.05 ha, halve the number of revolutions to 42.5.
- Weigh the seed
- The amount of calibrated seed does not necessarily correspond to the amount specified in the table. For example, one reason for this is the difference in the thousand grain weight.
- Convert the difference to the quantity in the table into percent
- Correct the adjustment value at the metering device up or down by this percentage. When doing this, ensure there is no seed in the metering device if you are decreasing the cell width.

□

- Reattach the elbow and secure it to the bracket with a bolt
- Once calibration is complete, ensure that drive shafts are connected securely with securing pins before you set off to work.

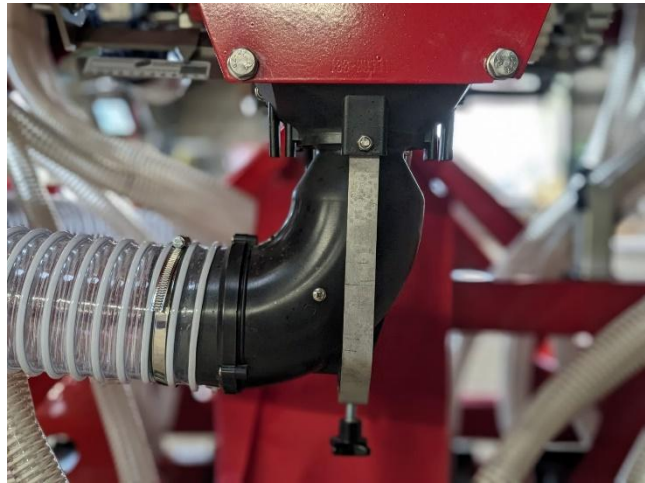

## Hydraulic Drive Fan

The oil flow is directed to the 3-way flow control valve and is thus regulated according to the speed of the hydraulic motor. The constant oil flow rate results in a specific rotational speed of the hydraulic fan drive. The speed can be viewed via the display in the tractor cab via a speed sensor which is attached to the hydraulic motor.

### Safety precautions

Moore Unidrill does not accept liability for damage due to incorrect usage of the drill to either the drill or tractor. Only trained and competent persons should carry out repair and changes to the Hydraulic Fan. At all times, disconnect the hydraulics before working on the machine.

### Product data

Hydraulic motor		Oil Flow (Rate)	Fan
Displacement (cm <sup>3</sup> )	Speed (rpm)	(l/min)	Fan Speed (rpm)
8	4200	40	4200

## Requirements for the hydraulic fan drive on the tractor:

- Sufficient oil supply by the tractor
- The appropriate number of control valves is available
- Parallel operation of the control valves is possible
- Oil cooler is available

## Installation of hydraulic hoses

Oil escaping under high pressure can penetrate clothing and skin and causes serious injuries. In case of injury, emergency first aid services should be called.

Always fit the hydraulic hoses so that they won't be damaged or exposed to chafing while lifting the seed drill up and down in work.

## Connecting to the tractor

The freeflow return prevents damage to the hydraulic motor.

- ! Maximum permissible pressure in the freeflow return is 10 bar.  
The hydraulic motor will be damaged by overpressure.

Following points must be considered when selecting the position of the freeflow return connection to the tractor hydraulic system:

- Return oil must flow through the tractor hydraulic filter system
- Return oil must not flow through any regulation valves (freeflow return) to avoid any back pressure.

## Operation of the hydraulic fan

- ! The fan speed on the hydraulic fan drive must not exceed 5000 rpm. At higher speeds the fan can be destroyed by explosion, causing serious damage to the machine. Only adjust the revolution speed while the fan is switched off.

A= Input to the hydraulic valve/motor  
B= Outlet from the hydraulic valve/motor  
P= Input (From the tractor)  
T= Outlet (freeflow return)

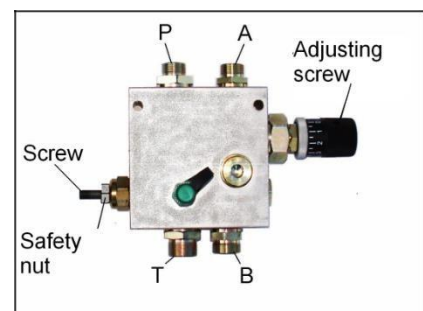

## Tractors with flow control valve

The 3-way flow control valve is completely open when the adjusting screw is fully screwed in.

- Fully open the 3-way flow control valve
- Actuate control valve on tractor
- Set the desired fan speed by regulating the oil flow rate on the tractor

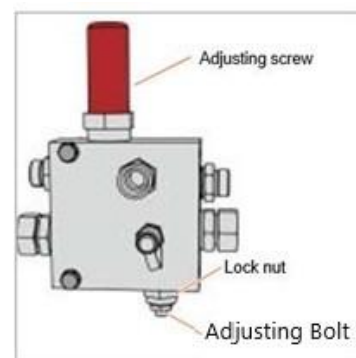

## Tractors without flow control valves, without regulating pumps

- Fully open the 3-way flow control valve

## Tractors without flow control valve, with regulating pumps (e.g. Fendt and others)

The flow control valve must be converted from 3-way to 2-way. Perform the conversion as follows:

- Release the lock nut
- Thread in the adjusting bolt completely. The conversion to a 2-way flow control valve is now completed.
- Retighten the lock nut
- Gradually engage the tractor's hydraulic flow, starting at a low setting and increasing it steadily until the desired fan speed is achieved.

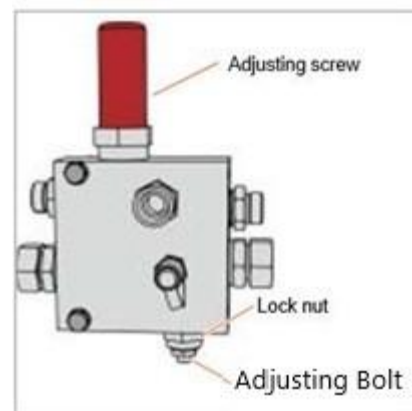

# Care and Maintenance

All maintenance should be carried out with machine unhitched, with packer roller in the lowest position, the top link unattached, and both front stands in park position. There is no need ever to get underneath the machine whilst mounted on the tractor. All maintenance and checks can be achieved whilst in the park position. In the highly unlikely event of coulter blockage, this can be relieved, by undoing the corbin clips which attach the flexible seed pipes to the top of the tungsten seed tube coulters and relieving the blockage with a long screwdriver or piece of stiff wire from above. When removing articles for service, please observe HSE manual handling guidelines.

## Self-Cleaning Prism Packer Roller

The packer roller is self-cleaning except at each end, where the hardox scrapers work to clean the back-to-back 50cm rings. Scrapers should be adjusted and replaced as necessary.

The packer bearings (1 on each end, and 2 in the middle) should be greased every 20 hours of work and before storage.

## Nuts and bolts

All nuts and bolts should be checked regularly. When working in stoney or trashy conditions it will be necessary to check all nuts and bolts daily, particularly the seed tube coulters and disc bolts.

## Seed tube coulter adjustment

Check the position of the seed tube coulters in relation to the disc coulters daily.

For most seeding conditions and generally the tip F of the seed tube coulter should be set so that it is approximately 12mm above the outer edge of the disc.

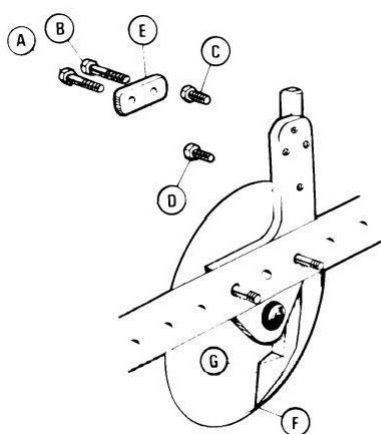

The leading edge of the seed coulter should be set parallel to the disc and just touching it. This can be achieved by means of the retaining bolts A+B and the adjusting screws C+D. If the tip, F, of the seed coulter is out from the disc, this can be corrected by tightening bolt A (front bolt) more than bolt B, while the top, G, of the seed coulter can be brought in towards the disc by tightening bolt B (rear bolt) more than bolt A. Some discs may be slightly distorted, but when in work the side force of the soil on the disc will keep it in contact with the seed coulter. A certain amount of bedding in and wear takes place between the disc and the seed coulter, and it may become necessary to adjust screws C+D to position the seed coulter closer to the disc.

## Daily maintenance

- Clean the brush for the fine seed barrel regularly to avoid blockages.
- Grease the PTO shaft yokes and guards daily through the appropriate nipples.
- Grease all the pivot points provided with grease nipples.
- Check the fan belt for tightness and adjust it if necessary.
- Check all nuts and bolts for tightness before starting work and during the first 40 hours.
- Check all wearing parts for tightness and breakage and replace them if necessary.
- Check all electrical connectors

## Emptying the hopper and metering system

- After drilling, the hopper and metering system must be emptied completely.
- To empty the hopper, place a suitable container or a seed collector sheet under the hopper and open the gate valve.

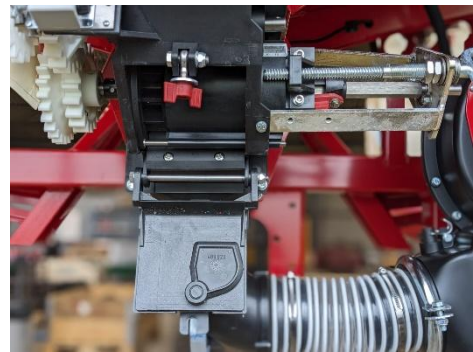

- You can also turn the drive wheel or the hand crank to completely empty the cells.
- Place a suitable container or seed collector sheet under the metering device
- Open the emptying flap
- Catch the seed
- Close the emptying flap

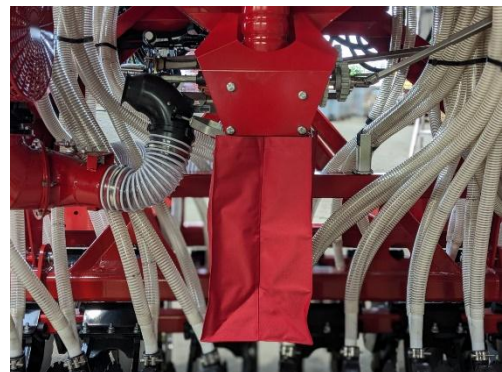

## **Dampness**

If water enters inside the hopper and tubes, it is important to run the fan until the tubes are dry to avoid seeds and dressing mixing with the moisture and creating blockages.

## **Storage and post season**

Before storing the machine, check all the parts for wear and damage and replace them as necessary.

When parking the machine, always use the parking legs fitted to the coulter bar to relieve the weight from the coulters and discs.

Protect all the electrical connectors with water repellent products.

# Wearing Parts

- 1. PA900597 UCF 40mm Bearing
- 2. PA900354 45cm Special End Ring
- 3. PA900420 Hardox Scraper Holder
- 4. PA900595 Hardox Scraper
- 5. PA900464 50cm Ring
- 6. PA900331 45cm Ring
- 7. PA900892 1470mm Shaft

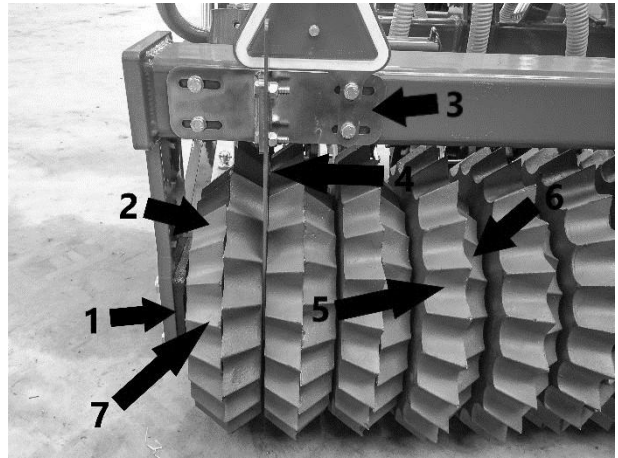

- 1. PA900775 LH 90mm Spacing Disc Arm
- 2. PA900776 RH 90mm Spacing Disc Arm
- 1. PA900777 LH 125mm Spacing Disc Arm
- 2. PA900778 RH 125mm Spacing Disc Arm
- 3. PA900021 Rubber Cord 300mm
- 4. PA900002 M12 Nyloc Nut
- 5. PA900028 M12 x 40 Cup Head Sq Bolts
- 6. PA900616 Suspension Arm Upper
- 7. PA900026 M10 x 70 Bolt
- 8. PA900013 Seed Tube Retaining Plate
- 9. PA900089 M10 x 20 Set Screw
- 10. PA900152 RH 30mm Coulter (Tungsten)
- 11. PA900153 LH 30mm Coulter (Tungsten)
- 12. PA900029 5 Hole Hub Bearing
- 13. PA900007 3/8" Spring Washer
- 14. PA900010 3/8" x 3/4" UNF Set Screw
- 15. PA301515 M16 Binx Nut
- 16. PA900008 415 x 5mm Notched Disc

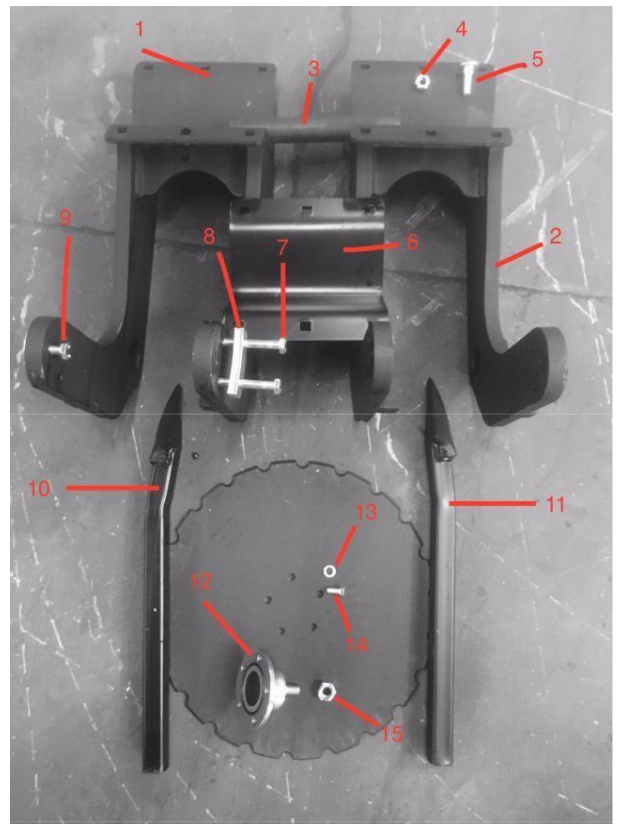

## Parts list of common serviceable components

Part No	Material	Quantity
PA900029	Moore Unidrill Peer Hub 5 hole 3/8" UNF	1
PA900775	LH 90mm Spacing Grass Suspension Unit	1
PA900776	RH 90mm Spacing Grass Suspension Unit	1
PA900777	LH 125mm Spacing Arable Suspension Unit	1
PA900778	RH 125mm Spacing Arable Suspension Unit	1
PA900779	LH 125mm Spacing Arable <i>Outer</i> Suspension Unit	1
PA900780	LH 125mm Spacing Arable <i>Outer</i> Suspension Unit	1
PA900616	Upper Suspension Arm Bracket	1
PA900008	Moore Unidrill Notched 415x5mm Disc 5 Hole	1
PA900152	Right Hand Tungsten 30mm Coulter	1
PA900153	Left Hand Tungsten 30mm Coulter	1
PA900010	3/8 X 3/4" UNF SET SCREW	5
PA900007	3/8 Rectangular Spring BZP Washer	5
PA900013	Seedtube Retainer Plate	1
PA900035	Rubber Cord 240mm (For Grass 90mm Spacing)	4
PA900021	Rubber Cord 300mm (For Arable 125mm Spacing)	4
PA900028	M12 x 40 Cup Head Square Bolt 8.8	8
PA900465	Cat 3 Top Link Pin	1
PA900422	Cat 3 Bottom Link Pin	2
PA900274	Cat 2 Top Link Pin	2
PA900421	Parking Legs LH/RH (Pair)	2
PA900052	7/16 Lynch Pin	15
PA900626	LED Lights	2
PA900349	7 Pin Plug	1
PA900423	Light Mounting Brackets LH/RH (Pair)	2
PA900420	Guttler Scraper Mounting Plate	2

Part No	Material	Quantity
PA900595	Guttler Hardox Scraper	2
PA900457	Drive Wheel Rest	1
PA900597	Guttler Packer Bearing	4
PA900354	Guttler 45cm End Ring	4
PA900464	Guttler 50cm Ring	26
PA900331	Guttler 45cm Ring	22
PA900892	1472mm Packer Shaft	2
PA900509	1.25" Washer Pin & Split Pin	2
PA900652	1/4" Lynch Pin	2
PA900879	Hectametre	1
PA900017	Hose Corbin Clip	1
PA900054	Hose Holder Plastic Sleeve	1
PA302914	Replacement Landwheel for 3m	1
PA900639	27kg Wafer weights	20
PA900215	Amber Reflector Amber Round Sticky	2
PA900654	Top Link Cat 2	1
PA900628	LED 2 Chamber Rear Lamp c/w 7m	2
PA900312	Red/White Triangle Reflector	2
PA900273	Hydraulic Cylinder 420x134 Stroke Ram	2
PA900863	7 Pin Stocket Mounting Bracket	1

# Techniques

The Moore Unidrill prepares its own mini seedbed by using an angled disc and seed tube coulter tine. All seeds are planted at a constant depth. The points of the Guttler roller slit the ground 305 times per square meter, to give good seed soil contact, however in some conditions another pass with a roller is necessary. In all conditions, drilling should be conducted in reasonably straight lines as turning with the drill engaged in the ground, can cause premature bearing failure, and blockages, by pulling the disc away from seed tube coulters.

## **Direct drilling grass or clover into grass**

A healthy field of grass is one of the most valuable assets a livestock farmer can have, and direct drilling can help you grow more and better grass at less cost, because there is less labour, machinery and time involved. Other benefits are reduced poaching, a reduction in the number of broad-leaved weeds. The direct drilling of grass into either a short-term or mid-term sward is a simple enough matter, and even long-term worn out pastures can be reseeded with the direct drill provided a few precautions are observed.

A one-to-ten-year-old sward which is open, presents few problems having had no time to build up any substantial quantity of mat/thatch under the surface. As a rule of thumb, if you can sink the disc into 25mm of 80% clean soil and not root mat/thatch, then you are in business. As with all reseeding, weather plays an important part, but with reasonable moisture and heat the following methods may apply for successful seeding.

### **Method 1, No chemical top up. Clean (weed free) open swards following silage**

Where a final cut of silage has being taken, and the field is going to grazing, cut low to the ground and direct drill 1/2 to full rate seeds as soon as possible, whilst moisture is retained in the ground, and before the regrowth starts. There should be enough moisture retained in the ground to get the seeds germinated and provided it doesn't dry out subsequently due to lack of rain, seed should be established before the old sward has fully recovered and should be grazed with young stock or sheep 2 to 4 weeks later, depending on growing conditions. This grazing keeps the old grass down, stops the old sward choking the new seedlings, and allows light into the newly established grass. This sward should be grazed in 2/3 weekly intervals until the end of the season, never overgrazing as this can cause the new seedlings to be pulled out. Newly established grass often does not normally become apparent until the regrowth following first cut the following season.

Check the pH of ground prior to seeding and apply lime as necessary to get the ideal pH of 6.5, especially with clover. A light to medium coat of slurry immediately after seeding (depending on moisture) can be applied providing it contains no effluent or dairy washings.

### **Method 2, No chemical top up. Clean (weed free) open swards following grazing**

Graze the sward bare, using a mob stocking rate, harrow/rake/roll the dung pats, if necessary, drill the sward, and keep the stock grazing on, until the new shoots are just visible. As above re graze in 2 to 4 weeks' time, depending on growth.

Check the pH of the ground prior to seeding and apply lime as necessary to get the ideal pH of 6.5, especially with clover.

A light to medium coat of slurry immediately after seeding (depending on moisture) can be applied providing it contains no effluent or dairy washings

### **Method 3, Early Spring drilling**

If the pasture has been badly poached, or there are bad patches due to frost kill, leatherjackets, pests etc, over the winter, new grass seeds should be drilled in just before growth starts in springtime.

Check the pH of the ground prior to seeding and apply lime as necessary to get the ideal pH of 6.5, especially with clover.

A light to medium coat of slurry immediately after seeding (depending on moisture) can be applied providing it contains no effluent or dairy washings.

### **Method 4, Complete sward destruction**

Where the old sward is very weedy, and a complete re seed is required, spray with glyphosate pre or post-harvest/grazing to get a total kill off of all vegetation, and direct drill with a new seeds mixture.

### **Following grazing**

We prefer to graze tight, harrow/rake/roll as necessary after grazing, to disperse dung pats, then direct drill, and then leave up to a week before spraying off, or certainly before the new seeds germinate. This procedure helps get a good regrowth going to take the chemical, without affecting seed germination.

Check the pH of the ground prior to seeding and apply lime as necessary to get the ideal pH of 6.5, especially with clover.

A light to medium coat of slurry immediately after seeding (depending on moisture) can be applied providing it contains no effluent or dairy washings.

## After silage

Cut the silage first rather than apply glyphosate pre harvest, at the recommended 5 days, as this prevents any wheeling's from the sprayer appearing in subsequent crop, also Glyphosate seems more effective on less volume of grass. By delaying drilling up to a week after cutting, regrowth will have started, and then drill, and delay spray application up to another week, at least before the new seed germinates. This has the effect of giving another week's regrowth to take the chemical.

The downside of the above techniques is that the grass damaged at the disc row during drilling, is sometimes not adequately controlled by the glyphosate.

Check the pH of the ground prior to seeding and apply lime as necessary to get the ideal pH of 6.5, especially with clover.

A light to medium coat of slurry immediately after seeding (depending on moisture) can be applied providing it contains no effluent or dairy washings.

## Method 5, Older leys, rough permanent grass old, worn-out pastures

These need to be approached with care. Although Glyphosate deactivates in contact with soil, there is a problem with toxic phenol and acetic acids being released by old decaying sprayed off vegetation, so if there is a thick mat or subsurface mat of roots and fibre, and inevitably the seed is placed near this mat, then germination problems can occur due to localized acidic soil. This is worse in wet anaerobic conditions, before during or after seeding. The problem with direct drilling into sprayed off grass or anything else that has a large root mat is that it is always a big gamble depending on the weather, especially after you have drilled, which is why some people say it's successful and others don't. An analogy is that silage (decaying grass) made in wet conditions is always more acidic when opened.

In a heavy mat situation, waiting for long enough for all the plants to die completely after spraying is the only way to guarantee success with direct drilling on old, matted pastures, otherwise you need to either shallow cultivate and roll, to increase the oxygen levels or if you're feeling lucky take a gamble, that the sward won't lie wet after drilling. If you had a thick mat of decaying vegetation and spun bean seeds on the surface and then ploughed them in, you would get the same results. So, either spray off in spring and drill in autumn, after a lime application, and probably another lower rate spray, predrilling, or less production can be lost by spraying off in autumn, applying lime, and drilling in early spring, when a further lower rate spray is usually necessary.

In a lower more marginal mat situation, the application of lime alone can help neutralize the effects of the acidic decomposition, but like all seeding techniques depend on moisture and ground heat. In this situation, we recommend the delayed glyphosate application techniques discussed above, that is to delay glyphosate application until after seeds have been planted, but before they germinate, so that the seeds get maximum exposure to germination, establishment, and deeper rooting before the acidic effects of the decaying plant material come to bear.

A few test sites dug with a spade; will help you decide on the subsurface mat/thatch problems that might be present.

Direct drilling after sprayed off temporary or more open leys isn't usually a problem as the root matt isn't big enough to damage seedlings with its acids and phenols.

In all the above cases use a vigorous quick establishing grass seed mixture up to 35kg/ha.

There is no doubt that a blend of 50% Perennial Hybrid (tet), 25% Intermediate tet and 25% diploid works best. These are mostly larger seeds with greater energy reserves for coping with adverse situations. Italian ryegrass swards can easily be re-established at the end of their allotted production cycle, by re drilling typically after the third season.

### **Sowing into ploughed, pre cultivated and looser seedbeds.**

By running the packer in the highest position, and therefore least pressure on the coulters, seed can be laid on top, or shallow in ploughed or pre cultivated seedbeds.

The Guttler press wheels will make a nice job of firming the seed into the soil, without the risk of capping, and no further rolling need take place if required.

### **Sowing into cereal stubble**

It is recommended to run at a slight angle to the existing stubble, approximately 10 to 15 degrees, so that the discs are never constantly running on a row of stubble and are therefore running in and out of the existing stubble rows.

# EU DECLARATION OF CONFORMITY

Declaration No. 300G1

## **We, the undersigned**

Moore Unidrill (Manufacturing) Ltd  
Randalls Farm, Scotlethorpe Road,  
Edenham, Bourne, Lincs. PE10 0LN

## **Declare under our sole responsibility that the following apparatus:**

Name: MOORE UNIDRILL  
Model: MDH-1700  
Type: MOUNTED  
Serial number:

## **Is in conformity with the following relevant EC legislation:**

2006/42/EC

## **Based on the following Harmonised standards:**

EN12100-2:1998  
BS EN ISO 14121-1:2007  
EN 982:1996+A1:2008

## **And Non-Harmonised standard:**

BS ISO 4254-9:2008

## **Risk Analysis was carried out using the following standard:**

BS EN ISO 14121-1:2007

**We, the undersigned, undertake to transmit, in response to a reasoned request by national authorities, relevant technical information for the machinery.**

**Name and position of person binding the manufacturer:**



**Signature** \_\_\_\_\_

**Name** Jonathan Whyles  
**Function** Operations Director  
**Location** Randalls Farm, Scotlethorpe Road, Edenham, Bourne, Lincs. PE10 0LN  
**Date of issue** 26/02/21

