



IAS
AUTOMATION



Digitized Automation for a Changing World

Delta Human Machine Interface DOP-100 Series



www.deltaww.com



Advanced Human Machine Interface for

Delta's Human Machine Interface DOP-100 Series includes four categories for different applications: Basic, Standard, Advanced, and Handheld. The Basic, Standard, and Handheld HMI adopt the latest Cortex-A8 (800 MHz), while the 12"/15" Advanced HMI adopts the Dual Core Cortex-A7 1Ghz high-speed processor. The DOP-100 Series employs 16-bit or 24-bit color LCD screens with high brightness and contrast. In addition, the series is equipped with the HMI programming software DIAScreen and built-in Lua editor for easy programming as well as alarm / history log / user authority functions for highly efficient management.

With advanced communication capabilities and enhanced functions, the DOP-100 Series enhances machine efficiency to bring more value to our customers, and to achieve "Automation for a Changing World"!



Standard HMI

Features General and Ethernet Types for various applications

Advanced HMI

Features narrow frame design, supports various network communications, multilingual input and multimedia functions

Future Industry

Basic HMI

Simple operating structure for harsh environments



Handheld HMI

Customized for the teaching needs of various motion platforms such as robotic arms

Table of Contents

| | |
|---|----|
| <u>Introduction</u> | 2 |
| <u>Robust Hardware</u> | 16 |
| <u>Programming Software – DIAScreen</u> | 17 |
| <u>Advanced Alarm</u> | 22 |
| <u>Data Management</u> | 24 |
| <u>User Authority Management</u> | 26 |
| <u>Network Functions</u> | 27 |
| <u>Product Information</u> | 28 |

Easy Model Selection

The DOP-100 Series offers diverse models for different applications. Users can easily select a suitable HMI based on size or function

| | | |
|------------------|--|----------------------------------|
| S Type | ▶ Serial Communication Port x2 (D-sub x1) | |
| B Type | ▶ Serial Communication Port x2 (D-sub x1) | |
| D Type | ▶ Serial Communication Port x2 (D-sub x1) | ▶ Ethernet port x1 (RJ45 x1) |
| C Type | ▶ Serial Communication Port x3 (D-sub x2) | |
| P Type | ▶ Serial Communication Port x3 (D-sub x2) | ▶ Ethernet Port x1 (RJ45 x1) |
| E Type | ▶ Serial Communication Port x3 (D-sub x2) | ▶ Ethernet Port x1 (RJ45 x1) |
| I Type | ▶ Serial Communication Port x3 (D-sub x3) | ▶ Ethernet Port x1 (RJ45 x1) |
| H Type | ▶ Serial Communication Port x1 (D-sub x1) or Ethernet Port x1 (RJ45 x1) | |
| W Type | ▶ Serial Communication Port x2~4 (D-sub x1~2) ▶ Narrow frame design , Multi-language | ▶ Ethernet Port x1~2 (RJ45 x1~2) |
| M Type | ▶ Serial Communication Port x4 (D-sub x2) ▶ Narrow frame design , Multi-language, Multi-media | ▶ Ethernet Port x2 (RJ45 x2) |

Type Definition

DOP-107 W V



Advanced HMI

At least 2 Serial Communication Ports & 1 Ethernet Port included

Handheld HMI

1 Serial Communication Port (RS-422 / RS-485) or 1 Ethernet Port

Standard HMI

3 Serial Communication Ports included

Basic HMI

2 Serial Communication Ports included



Advanced Narrow Frame



Advanced Multimedia

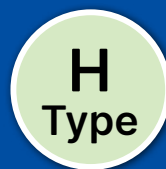

Handheld

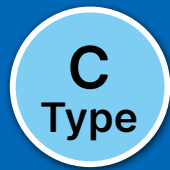

Standard General



Standard Premium



Standard Ethernet (2COM)

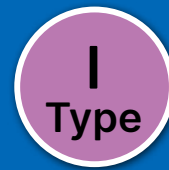

Standard Ethernet (3COM)



Simple



Basic



Basic Ethernet

Advanced HMI

The Advanced HMI adopts a wide screen and narrow frame design. It supports Ethernet communication & multilingual inputs. The Multimedia Type DOP-112 / 115 offers multimedia functions to meet different applications.



Features

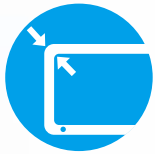

Narrow Frame
Enlarged visual display for a better user experience



LUA Language
Simple and easy structural programming language to meet various demands



Pressing Times >10,000,000
Effective pressing times validated by strict endurance tests



IP65 Rating
Protects the HMI from rain and dust



Multilingual Input
16 different languages input for easy operation



Diagnostics Function
Collects and troubleshoots issues remotely



Power Isolation
Protects the HMI from accidental surge interference



VNC Remote Monitoring
Remote control with mobile devices



QRcode Scanning
Generates QRcodes for mobile device identification



Supports GIF Graphic Elements
Easy setting to play vivid GIF elements



Embedded Linux System
Open system for flexible and stable program development



DIAScreen
New software DIAScreen offers more functions and a better interface



Operating Temperature 0°C ~ 50°C
Applicable in various industrial operating environments



CE / UL Certified
Compliant with CE and UL standards



Multimedia Functions
Captures images with an external camera or replays important recordings 



Ethernet Communication
Connects to a master device or PLC with high-speed Ethernet communication



Communication Isolation
Serial Communication Ports and Ethernet Ports with built-in isolation circuits enhance communication stability



OPC UA
Supports M2M communication and data transmission among machines from various manufacturers for diverse industries



FTP/eMail Supported
Simple data transmission and real-time status update



Supports PDF and TXT Reader
PDF and TXT files supported

Camera & Video Play Multimedia Functions



Analog Camera

Supports external camera via analog signals, suitable for capturing fast and short-distanced images

Applications: Textiles | Pharmaceutical | Rubber & Plastics



IP Camera

Supports IP Camera via Ethernet, suitable for capturing remote and wide-range images

Applications: Packaging | Logistics | Mining | Power Generation | Oil & Gas



VGA Input

Displays images from external devices such as machine vision systems, PCs or notebooks



Video Play

Views mpeg4 files captured by analog or IP camera from internal storage or USB disk / SD card



Event Trigger

Responds to preset event trigger conditions to capture images and archive as mpeg4 files



Multi-Language Input for Localization

▶ The Advanced HMI supports multilingual inputs for:

- Recipe Name (ENRCPG)
- Recipe Group Name (ENRCPNONAME)
- Recipe Content (Char)
- User Name

▶ Supports 16 languages: English, Traditional Chinese, Simplified Chinese, French, German, Russian, Japanese (Fullwidth or Halfwidth), Korean, Spanish, Portuguese, Hindi, Turkish, Arabic, Persian, Italian and Polish

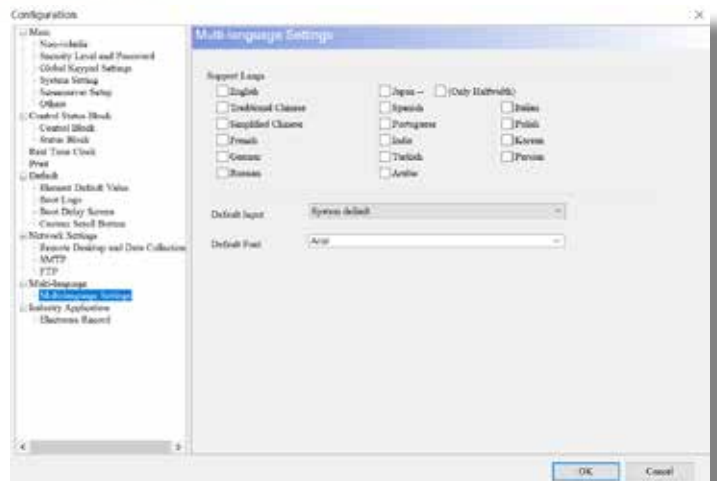

Delta's HMI can implement M2M communication and data transmission for diverse industries by means of OPC UA. Communication among different manufacturers' machines is enabled through information modeling.

Standard HMI

The Standard HMI is equipped with Serial Communication Ports to meet most applications. It also offers Ethernet Types for fast and easy connection with other equipment.



Features



Embedded Linux System
Open system for flexible and stable program development



LUA Language
Simple and easy structural programming language to meet various demands



DIAScreen
New software DIAScreen offers more functions and a better interface



Pressing Times >10,000,000
Effective pressing Times validated by strict endurance tests



Operating Temperature 0°C ~ 50°C
Applicable in various industrial operation environments



IP65 Rating
Protects the HMI from rain and dust



CE / UL Certified
Compliant with CE and UL standards



Diagnostics Function
Collects and troubleshoots issues remotely



Ethernet Communication
Connects to master device or PLC with high-speed Ethernet communication



Power Isolation
Protects the HMI from accidental surge interference



Communication Isolation
Serial Communication Ports and an Ethernet Port with built-in isolation circuits enhance communication stability



VNC Remote Monitoring
Remote control with mobile devices



FTP/eMail Supported
Simple data transmission and real-time status update



Supports PDF and TXT Reader
PDF and TXT files supported



Supports GIF Graphic Elements
Easy setting to play vivid GIF elements



User-Friendly
Intuitive operation interfaces for users

Basic HMI

The Basic HMI is easy to install and offers basic functions for general industrial applications. With an IP65 rating, it is suitable for harsh environments.

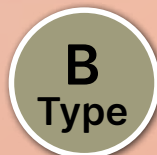

Features



Embedded Linux System
Open system for flexible and stable program development



LUA Language
Simple and easy structural programming language to meet various demands



DIAScreen
New software DIAScreen offers more functions and a better interface



Pressing Times >10,000,000
Effective pressing times validated by strict endurance tests



Operating Temperature 0°C ~ 50°C
Applicable in various industrial operating environments



IP65 Rating
Protects the HMI from rain and dust



CE / UL Certified
Compliant with CE and UL standards



Diagnostics Function
Collects and troubleshoots issues remotely



Ethernet Communication
Connects to master device or PLC with high-speed Ethernet communication

D Type Only



FTP/eMail Supported
Simple data transmission and real-time status update

D Type Only



Communication Isolation
An Ethernet Port with built-in isolation circuits enhances communication stability

D Type Only



VNC Remote Monitoring
Remote control with mobile devices

D Type Only



Supports PDF and TXT Reader
PDF and TXT files supported



Supports GIF Graphic Elements
Easy setting to play vivid GIF elements



User-Friendly
Intuitive operation interfaces for users

Handheld HMI

The Handheld HMI adopts a lightweight handheld design and supports Serial Communication Port (RS-422 / RS-485) or Ethernet communication. Meet the teaching needs of various motion platforms such as robotic arms.

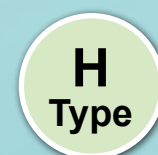

Features



Embedded Linux System

Open system for flexible and stable program development



LUA Language

Simple and easy structural programming language to meet various demands



DIAScreen

New software DIAScreen offers more complete functions and a better interface



Pressing Times >10,000,000

Effective pressing Times validated by strict endurance tests



Operating Temperature 0°C ~ 50°C

Applicable in various industrial operating environments



IP54 Rating

Protects the HMI from rain and dust



CE Certified

Compliant with CE standards



Diagnostics Function

Collects and troubleshoots issues remotely



Ethernet Communication

Connects to a master device or PLC with high-speed Ethernet communication



Power Isolation

Protects the HMI from accidental surge interference



Communication Isolation

Serial Communication Port / Ethernet Port with built-in isolation circuits enhance communication stability



FTP/eMail Supported

Simple data transmission and real-time status update



Supports PDF and TXT Reader

PDF and TXT files supported



QRcode Scanning

Generates QRcodes for mobile device identification



User-Friendly

Intuitive operation interfaces for users



Supports GIF Graphic Elements

Easy setting to play vivid GIF elements

Robust Hardware

Power Isolation

- ▶ The HMI with built-in power isolation circuits provides protection against accidental external spikes

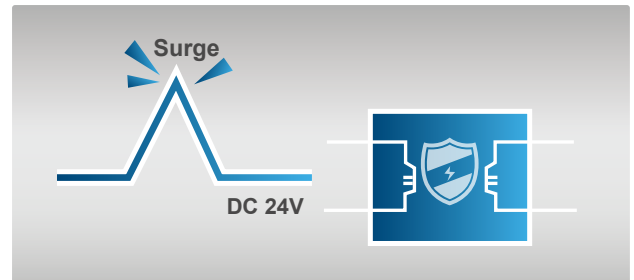

Isolated Communication Interface

- ▶ The HMI with built-in Serial Communication Port and Ethernet isolation circuits to protect against noise that can occur from the grounding of various devices such as PLCs, servo drives, motor drives and others



PCB Coating

- ▶ The DOP-100 series has PCB coating for enhanced durability and to protect against humidity and dust for applications in a range of environments

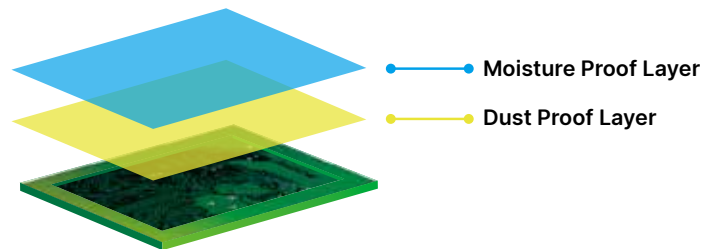

| Model | Power Isolation | Serial Communication Port Isolation | Ethernet Isolation |
|---------------------------------------|-----------------|-------------------------------------|--------------------|
| Advanced HMI (Multimedia Type) | | | |
| DOP-112/115 MX | Yes | Yes | Yes |
| Advanced HMI | | | |
| DOP-103WQ/107WV/110WS | Yes | Yes | Yes |
| DOP-112/115 WX | Yes | Yes | Yes |
| Handheld HMI | | | |
| DOP-107H | Yes | Yes | Yes |
| Standard HMI (Ethernet Type) | | | |
| DOP-107IV | Yes | Yes | Yes |
| DOP-108IG/110IG | Yes | Yes | Yes |
| DOP-110IS | Yes | Yes | Yes |
| DOP-107EV | Yes | Yes | Yes |
| DOP-107EG | Yes | Yes | Yes |
| DOP-107PV | No | No | Yes |
| Standard HMI | | | |
| DOP-105CQ | Yes | No | No |
| DOP-107CV | Yes | No | No |
| DOP-110CS | Yes | No | No |
| DOP-110CG | Yes | No | No |
| Basic HMI (Ethernet Type) | | | |
| DOP-103DQ | Yes | Yes | Yes |
| DOP-107DV | No | No | Yes |
| Basic HMI | | | |
| DOP-103SQ | No | No | No |
| DOP-103BQ | No | No | No |
| DOP-107BV | No | No | No |

Programming Software – DIAScreen

Abundant Elements

- ▶ Abundant built-in element graphics for vivid interface display for a variety of industrial applications

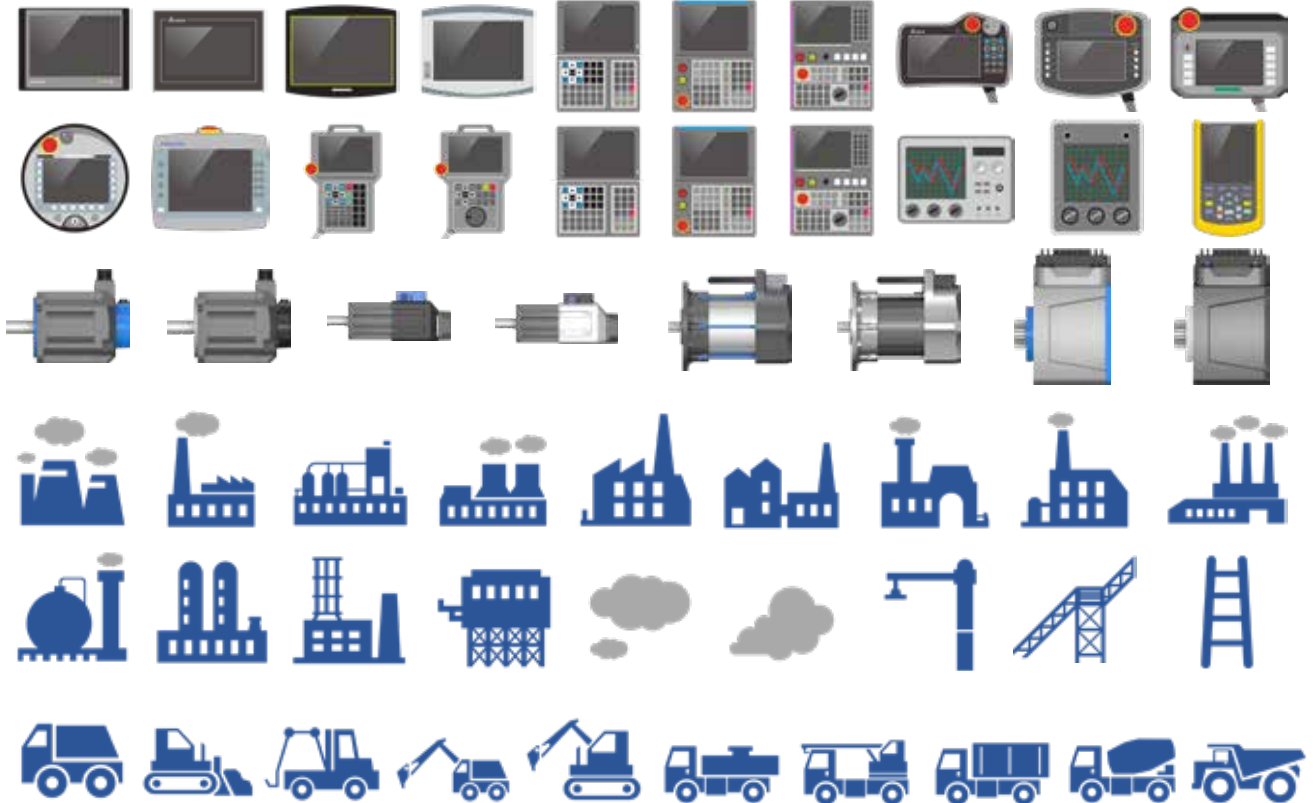

Smooth Animation

- ▶ New smooth animation technology for realistic dashboard display

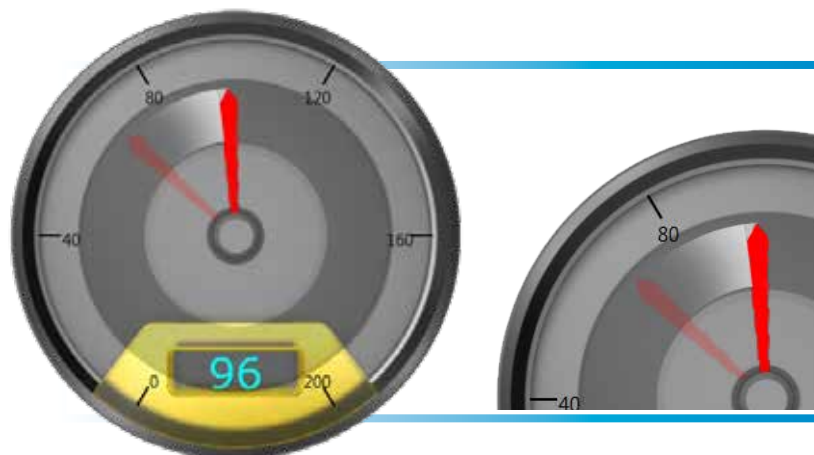

Programming Software - DIAScreen

User-Friendly Programming Interface

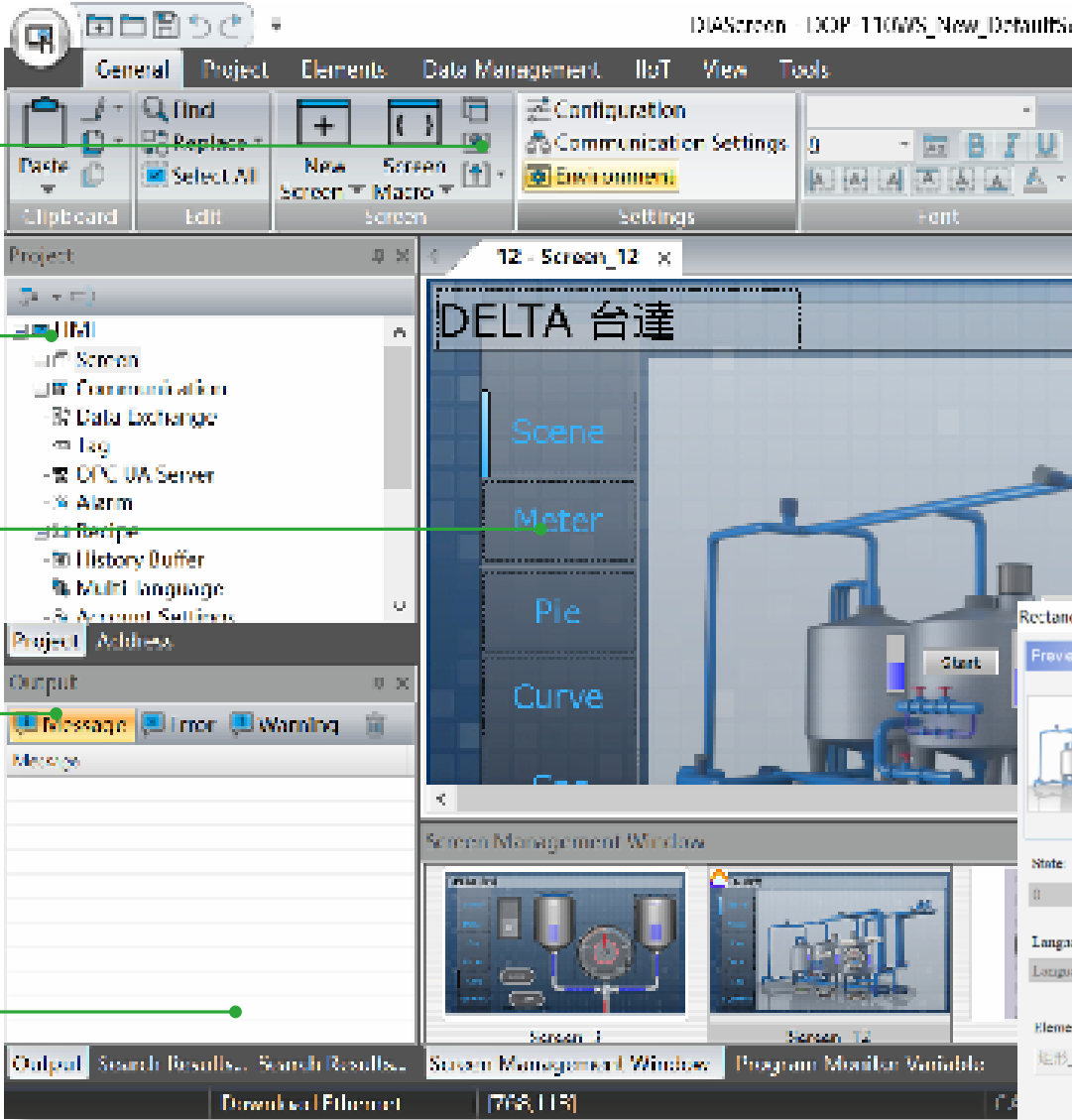

The screenshot shows the DIAScreen software interface with several callout boxes pointing to specific features:

- Bookmark Management**: A green box pointing to the 'Bookmark' icon in the top toolbar.
- Bookmark menu allows users to switch pages easily**: Text describing the function of the bookmark menu.
- Project Management Batch**: A green box pointing to the 'Project' menu in the top toolbar.
- Users can quickly switch items via the project branch feature**: Text describing the project management batch feature.
- Editing Area**: A green box pointing to the main workspace area where the screen is being edited.
- Provides real-time display of users' edits**: Text describing the editing area's real-time feedback.
- Output List**: A green box pointing to the 'Output' window at the bottom left.
- Automatically displays edit results of each screen. Users can review and troubleshoot by clicking screens**: Text describing the output list's functionality.
- Edit Preview**: A green box pointing to the 'Screen Management Window' at the bottom right.
- Users can quickly browse the overall project via edit preview**: Text describing the edit preview window's functionality.

Abundant Accessories

Customized keyboard



Field devices



Process paradigms

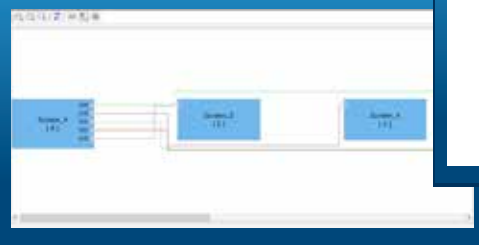

General Tool

Shortcut icons help enhance efficiency

Property

Provides easier property setup via group lists

Property Window

Standard accessory dialog box with built-in preview and quick-edit functions

Programming Software - DIAScreen

Editing Windows

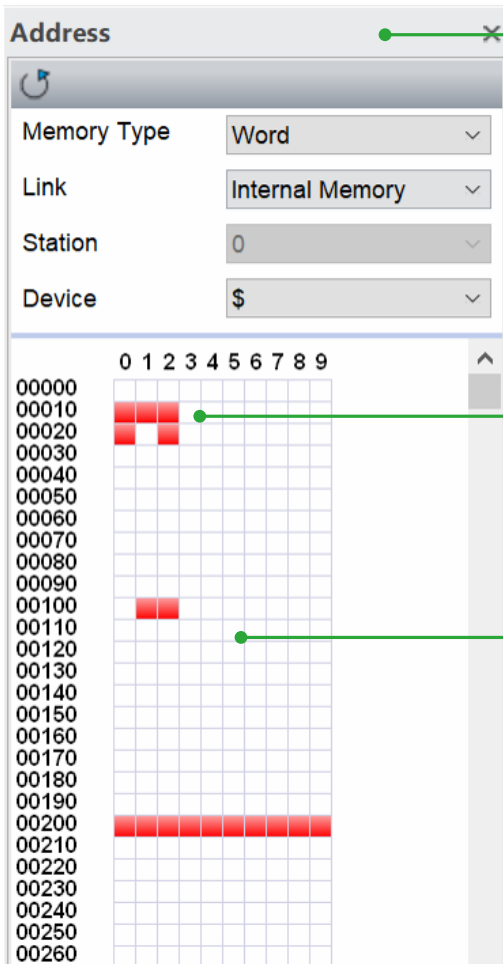

Register View Window

The color blocks of red and white allow users to view the memory register status



Red blocks indicate the used registers



White blocks indicate empty registers

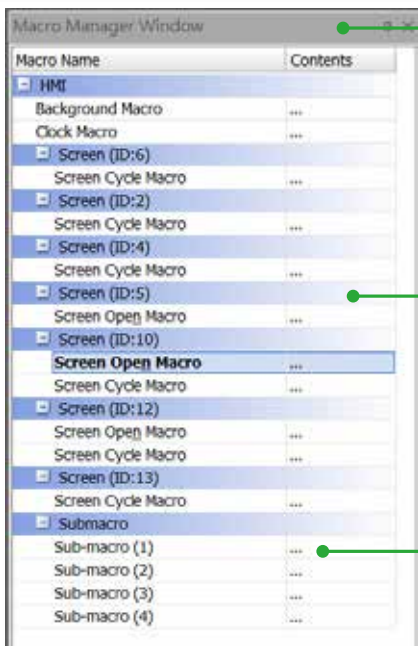

Macro Management Window

Users can view all types of macros in the project

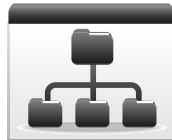

Select a macro via the list





Directly edit the macro after clicking

```

11
12 while true do
13
14   -- read from 020, 021
15   dx = mem.inter.Read(20)
16   dy = mem.inter.Read(21) / 10
17
18   -- get the path by cos formula
19   r = r + dy
20   x = x + dx
21   y = math.cos(r) * 100 + offsety
22
23   if (x < 0) then value = math.cos(radian) end
24   Parameters: radian: number, Radian
25   mem.inter: Returns: value: number
26   mem.inter: Example) cos(30 deg)
27   w = math.cos(math.rad(30))
28   mem.ir => ym.666020
29   mem.ir => 0, 0xFFEFFF
30
31   mem.inter.Write(2, 0xFF00)
32
33 end
  
```

Lua Tool Bar

-  Program debug
-  Stops program debug
-  Program break point

Online Coding Tips

Lua editor displays tip windows of the codes when users move the mouse to the selected codes

Watch variable

| Name | Value | Global / Local | Type | Format |
|------|-------|----------------|--------|--------|
| dx | 3 | Global | Number | DEC |
| dy | 0.1 | Global | Number | DEC |
| r | 0.1 | Global | Number | DEC |
| x | 3 | Global | Number | DEC |
| y | 0 | Global | Number | DEC |
| name | nil | Local | | DEC |

Parameter Monitoring Window

Allows users to monitor parameter variation during program development

Items

- Basic syntax
 - if then else elseif end
 - for var=1,3 do _ end
 - while
 - table, array
 - + * / % ^
 - function, call function
 - logic: xor and or not lshift rshift
- Internal memory - \$
 - mem.inter.Read
 - mem.inter.ReadDW
 - mem.inter.ReadFloat
 - mem.inter.ReadBit
 - mem.inter.Write

[Detail]

```

if (100 > 20) then
  -- do something
end

if (100 > 20) then
  -- do something
else
  -- do something
end

[boolean expression]
a = 100
if (a == 100) then equal = true end
if (a ~= 100) then not_equal = true end
if (a <= 100) then less_than_or_equal = true end
if (a >= 100) then greater_than_or_equal = true end
end
  
```

Programming Assistance Window

Provides online assistance as follows:

- Lua code templates
- Program usage and properties
- Program samples

Advanced Alarm

Strengthened alarm functions allow users to easily manage machine operations and quickly troubleshoot problems

- ▶ Alarm messages contain current register data for issue analysis

| Detail | | | Properties |
|--------|----------------------------|----------|------------|
| No. | Message Content | Category | |
| 1* | Temp. too High , PV is %d1 | 1 | |
| 2* | Temp. too Low , PV is %d1 | 1 | |
| 3* | PV is %d1 , ALM Mail | 2 | |
| 4 | | 0 | |
| 5 | | 0 | |

| Message |
|---------------------------|
| Temp. too Low , PV is 12 |
| Temp. too High , PV is 91 |
| Temp. too Low , PV is 15 |
| Temp. too Low , PV is 23 |

Alarm Sorting
 Alarm sorting via a "Sorting" function based on alarm attributes for quick information inquiries

Supports Compound Address Monitoring
 Monitors Word and Bit documents at the same time

| Detail | | Properties | | | | |
|--------|----------------------------|------------|------|---------|-------------------|-----------------|
| No. | Message Content | Category | Type | Address | Trigger Condition | Monitor Address |
| 1* | Temp. too High , PV is %d1 | 1 | Word | \$15 | \$15 > 70 | \$15 |
| 2* | Temp. too Low , PV is %d1 | 1 | Word | \$15 | \$15 < 30 | \$15 |
| 3* | PV is %d1 , ALM Mail | 2 | Bit | \$198.4 | On | \$15 |
| 4 | | 0 | Bit | None | On | None |

Versatile Alarm Triggering Conditions
 Triggering conditions can be setup via a built-in function, no external editing programs required

Alarm Notification

Automatically sends out alarm notification emails to logged-in recipients when alarms occur and supports the Secure Sockets Layer (SSL) protocol to ensure safe data transmission



- Indicates the alarm trigger and recovery time, and provides alarm acknowledge time / date (Ack) to confirm and monitor troubleshooting progress

| Message | Trigger | Ack | Recovery |
|---------------------------|---------------------|---------------------|---------------------|
| Temp. too Low • PV is 12 | 15:07:12 02/03/2017 | | 15:07:15 02/03/2017 |
| Temp. too High • PV is 91 | 15:07:15 02/03/2017 | 15:07:56 02/03/2017 | 15:07:22 02/03/2017 |
| Temp. too Low • PV is 15 | 15:07:22 02/03/2017 | | 15:07:25 02/03/2017 |
| Temp. too Low • PV is 23 | 15:07:28 02/03/2017 | 15:07:58 02/03/2017 | 15:07:34 02/03/2017 |

Alarm Filtering

Advanced address control filtering allows users to find specified alarm messages according to user needs

| Action | |
|---|--|
| Address control filtering allows users to find specified alarms | |
| No. | Action |
| 0 | Preset state, shows all triggered alarms |
| 1 | Hide alarms with "Recover Time" and "Ack Time" |
| 2 | Hide alarms with "Recover Time" |
| 3 | Hide alarms with "Recover Time" or "Ack Time" |
| 4 | Hide alarms with "Ack Time" |

Alarm Ordering

Displays alarms in the order of Trigger Time / Ack Time / Recover Time

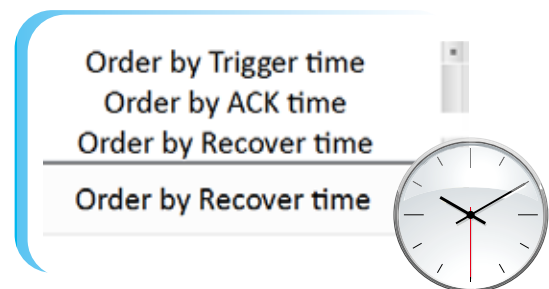

Data Management

Historical Data

- ▶ Generates historical reports with user-defined file names and timestamps through Bit Control

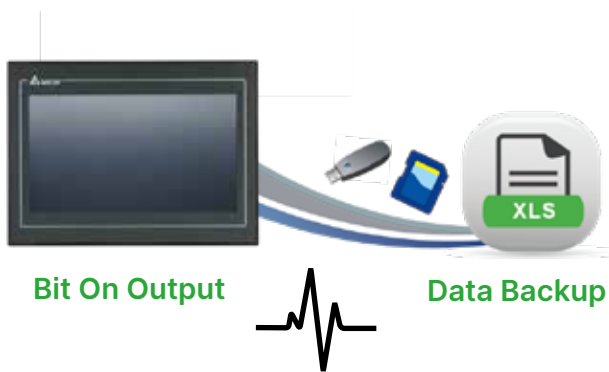

The 'Save As Mul' dialog box contains the following settings:

- File Date:** None, %m, %d
- File Time:** %H, %M, None
- File Name:** DOP
- Saving trigger:** \$175.0

Historical Data Review

- ▶ Allows historical data review on backup in USB disk or SD cards



Zoom In / Out Display

- ▶ Zoom in / out function for convenient data viewing

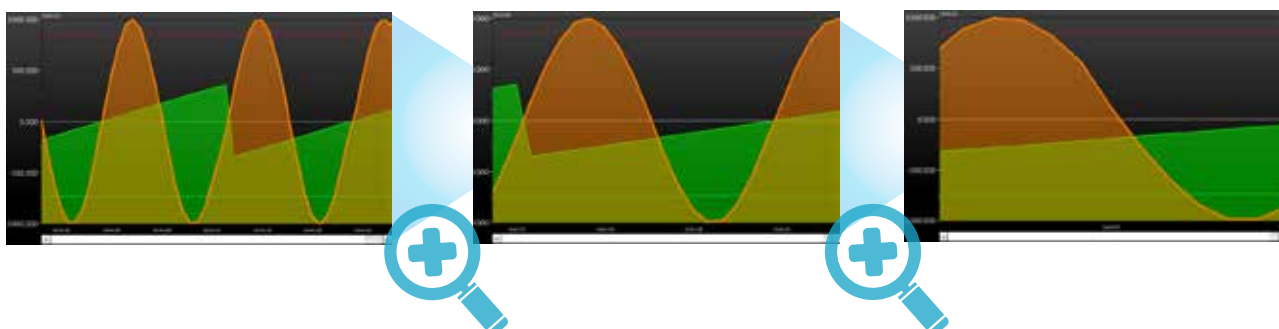

Recipes

- ▶ Supports 2D and 3D recipe grouping, for more flexibility in building recipe database
- ▶ Various recipe formats, including text format (Unicode) which can also be used as formula notes

| | D100 | D101 | D102 | D103 | D104 | D105 | D106 | |
|---------------|------------|--------------|---------|------|----------|-------|-------|------|
| | D100 | D101 | D102 | D103 | D104 | D105 | D106 | 50.7 |
| Cake Recipe 1 | Strawberry | 300 | 0 | 0 | 221.56 | 533.1 | 150.7 | 63.9 |
| Cake Recipe 2 | Chocolate | 0 | 300 | 0 | 387.98 | 490.8 | 163.9 | 79.8 |
| Cake Recipe 3 | Vanilla | 0 | 0 | 300 | 120.14 | 505.3 | 279.8 | |
| | Strawberry | Chocolate | Vanilla | | Sugar | Flour | Milk | |
| | Char | Unsigned DEC | | | Floating | | | |

Recipe Group 2 (includes rows 1-4)

Recipe Group 1 (includes rows 5-6)

- ▶ Recipes can be saved in CSV files for convenient editing on PCs
- ▶ Allows recipe update or backup through USB disks, SD cards or FTP

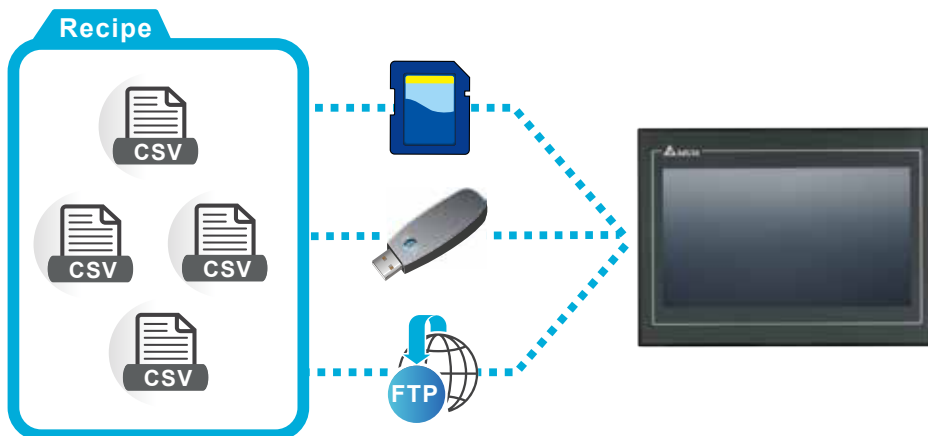

PDF for Data Review

- ▶ Users can save manuals or instruction PDF files in USB disks or SD cards for reference anytime



User Authority Management

Account and Authorization Management

- ▶ Supports 8 levels of authority and allows 20 accounts (account name/password) for each level to enhance operation safety
- ▶ Different function and operation access for each authority level to enhance operation safety
- ▶ Automatically logs out inactive users to ensure data security

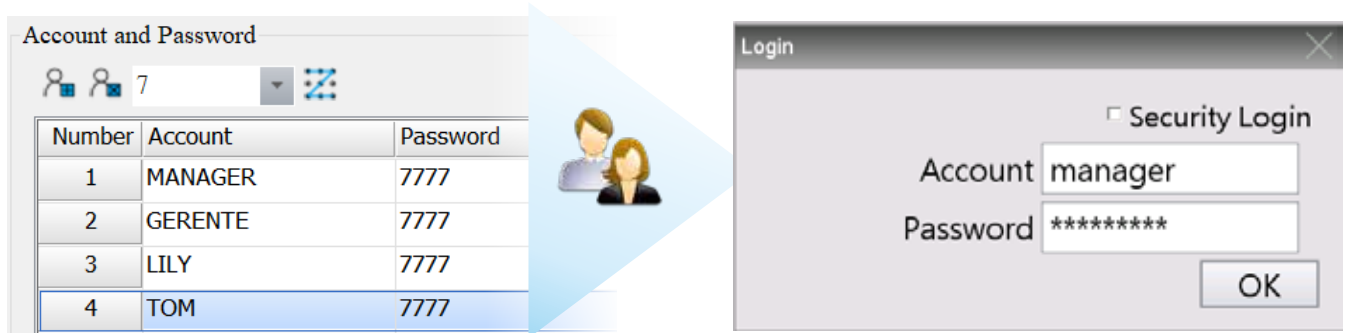

Operation Log

- ▶ Operation log for different user accounts to trace/analyze possible causes of malfunctions
- ▶ Provides comprehensive information for managers to analyze the operating habits of different users and enhance efficiency

| Time | Date | User | Level | Screen Description | Action | Address | Pre Value | Change |
|----------|------------|------|-------|----------------------|---------|---------|-----------|--------|
| 13:02:08 | 09/29/2020 | | 0 | Screen_Maintained_0 | Set Val | \$0.0 | 0 | 1 |
| 13:02:20 | 09/29/2020 | | 0 | Screen_Maintained_0 | Login | \$10.0 | | 11 |
| 13:02:20 | 09/29/2020 | 11 | 1 | Screen_Maintained_0 | Set Val | \$10.0 | 0 | 1 |
| 13:02:23 | 09/29/2020 | 11 | 1 | Screen_Numeric Entry | Set Val | \$100 | 0 | 99 |
| 13:02:28 | 09/29/2020 | 11 | 1 | Screen_Maintained_0 | Set Val | \$10.0 | 1 | 0 |
| 13:02:31 | 09/29/2020 | 11 | 1 | Screen_Maintained_0 | Set Val | \$10.0 | 0 | 1 |
| 13:02:34 | 09/29/2020 | 11 | 1 | Screen_Numeric Entry | Set Val | \$100 | 99 | 88 |
| 13:02:37 | 09/29/2020 | 11 | 1 | Screen_Maintained_0 | Set Val | \$0.0 | 0 | 1 |
| 13:03:04 | 09/29/2020 | 11 | 1 | Screen_Numeric Entry | Set Val | \$100 | 88 | 55 |
| 13:03:09 | 09/29/2020 | 11 | 1 | Screen_Numeric Entry | Set Val | \$100 | 55 | 33 |
| 13:03:10 | 09/29/2020 | 11 | 1 | Screen_Maintained_0 | Set Val | \$10.0 | 1 | 0 |
| 13:03:12 | 09/29/2020 | 11 | 1 | Screen_Maintained_0 | Set Val | \$10.0 | 0 | 1 |
| 13:03:16 | 09/29/2020 | 11 | 1 | Screen_Numeric Entry | Set Val | \$100 | 33 | 123 |

Network Functions

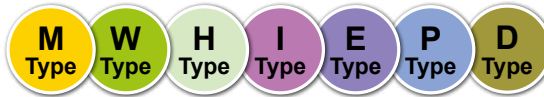

Only With Ethernet

FTP Server

- ▶ Built-in FTP server to update recipes or PDF files, and backup historical data, operation log and alarms

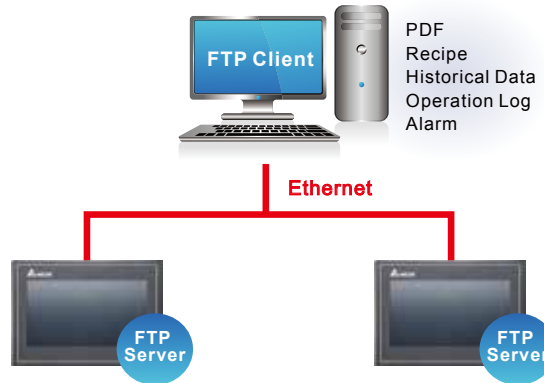

VNC Server

- ▶ Built-in VNC server allows remote monitoring and operating of the DOP-100 Series via VNC Client APP (Windows, iOS, Android)
- ▶ Lock function: blocks remote operation during on-site operation to avoid unsynchronized commands. The VNC server allows remote monitoring but not remote operation when the lock function is on

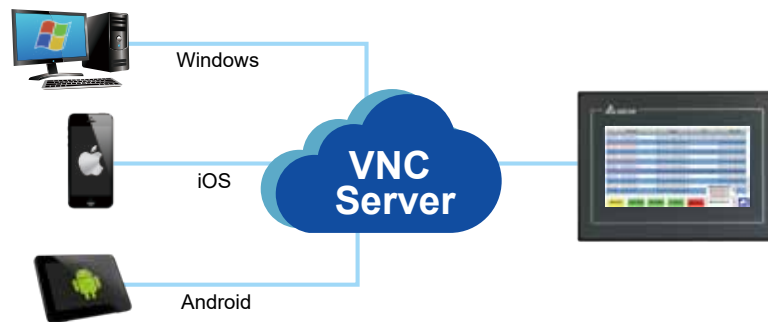

Web Monitoring

- ▶ Allows direct monitoring of register data via web page, and requires no additional software installation

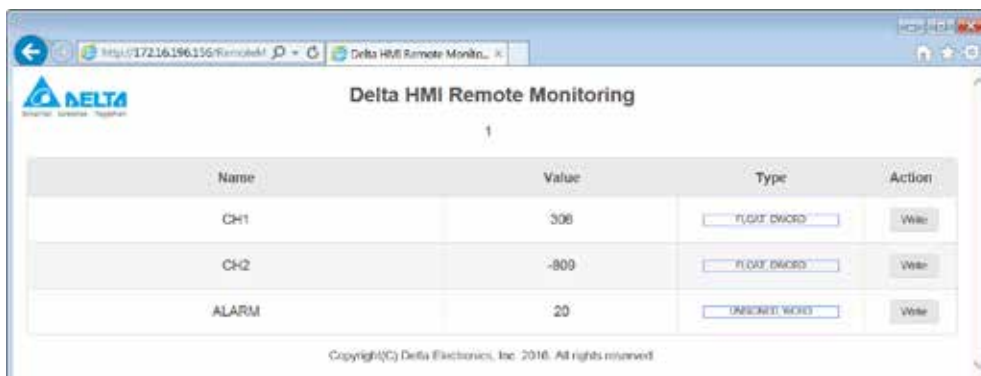

Hardware Specifications

Advanced HMI

| Model | | Advanced Narrow Frame Type | | |
|----------------------------------|--|---|---|--------------------|
| | | DOP-103WQ | DOP-107WV | DOP-110WS |
| LCD Module | Display | 4.3" TFT LCD | 7" TFT LCD | 10.1" TFT LCD |
| | Color | 16-bit | | |
| | Resolution (Pixels) | 480 x 272 | 800 x 480 | 1,024 x 600 |
| | Back Light | LED Back Light | | |
| | Back Light Brightness (cd/m ²) | 400 | 450 | 450 |
| | Back Light Life (Hour) ¹¹ | 10,000 | 20,000 | 30,000 |
| | Display Area | 95.04 x 53.856 mm | 154.08 x 85.92 mm | 225.52 x 128.10 mm |
| MCU | ARM Cortex-A8 (800MHz) | | | |
| Flash ROM (Bytes) | 256 MB | | | |
| RAM (Bytes) | 512 MB | | | |
| Touch Panel | Four-wire resistor, over 10,000,000 pressing times | | | |
| Buzzer | Multi-Tone Frequency (2K ~ 4K Hz) / 80dB | | | |
| Ethernet Interface | 1 Port ² , 10/100 Mbps auto-sensing | | | |
| USB | 1 USB Slave Ver 2.0 / 1 USB Host Ver 2.0 | | | |
| SD | N/A | | SD x 1 | |
| Serial COM Port | COM1 | RS-232 (supports hardware flow control) / RS-485 ² | RS-232 (supports hardware flow control) ² | |
| | COM2 ² | RS-422 / RS-485 ² | RS-232 (supports hardware flow control) / RS-485 ² | |
| | COM3 ² | N/A | RS-422 / RS-485 ² | |
| RTC | Built-in | | | |
| Cooling | Natural air circulation | | | |
| Certification | CE/UL (please use shielding Ethernet cables and magnetic rings with filters of 300 ohm / 100 MHz) | | | |
| Waterproof | IP65 / NEMA4 / UL Type 4X (indoor use only) | | | |
| Operation Voltage ³ | DC +24V (-15% ~ 15%) ² , supplied by Class 2 or SELV circuit (isolated from MAINS by double insulation) | | | |
| Voltage Endurance | AC500V for 1 minute (between charging DC24 terminal and FG terminals) | | | |
| Power Consumption ⁵ | Max. 5.8W ³ | Max. 8.4W ³ | Max. 11W ³ | |
| Backup Battery | 3V lithium battery CR2032 × 1 | | | |
| Backup Battery Life | Depends on the temperature used and the conditions of usage, usually about 3 years or more at 25° C | | | |
| Operating Temperature | 0° C ~ 50° C | | | |
| Storage Temperature | -20° C ~ 60° C | | | |
| Ambient Humidity | 10% ~ 90% RH (0 ~ 40° C), 10% ~ 55% RH (41 ~ 50° C), Pollution Degree 2 | | | |
| Vibration | IEC 61131-2 compliant 5 Hz ~ 8.3Hz = Continuous: 3.5mm, 8.3Hz ~ 150Hz = Continuous: 1g | | | |
| Shock | IEC 60068-2-27 compliant 15g peak for 11ms duration, X, Y, Z, directions for 6 times | | | |
| Dimensions (W) x (H) x (D) mm | 137 x 103 x 37.1 | 196 x 136 x 39 | 270 x 180.9 x 47.25 | |
| Mounting Dimensions (W) x (H) mm | 118.8 x 92.8 | 186.8 x 126.8 | 255 x 170.5 | |
| Weight | 280g | 560g | 1,100g | |

1) The half-life of a backlight is defined as the original luminance being reduced by 50% when the maximum driving current is supplied to an HMI.

2) Built-in power isolation

3) An isolated power supply is recommended.

4) Some models are in the process of application for UL and KCC certification. For more information, please consult our distributors.

5) The value of the power consumption indicates the electrical power consumed by the HMI with no peripheral devices connected.

6) The content of this catalogue may be revised without prior notice. Please consult our distributors or download the most updated version at <http://www.deltaww.com>

Advanced HMI

| Model | | Advanced Narrow Frame Type | | Advanced Multimedia Type | |
|----------------------------------|--|--|----------------------|--------------------------|------------------|
| | | DOP-112WX | DOP-115WX | DOP-112MX | DOP-115MX |
| LCD Module | Display | 12" TFT LCD | 15" TFT LCD | 12" TFT LCD | 15" TFT LCD |
| | Color | 24-bit | | | |
| | Resolution (Pixels) | 1,024 x 768 | | | |
| | Back Light | LED Back Light | | | |
| | Back Light Brightness (cd/m ²) | 500 | 450 | 500 | 450 |
| | Back Light Life (Hour) ¹ | 50,000 | | | |
| | Display Area | 245.76 x 184.32 mm | 304.1 x 228.1 mm | 245.76 x 184.32 mm | 304.1 x 228.1 mm |
| MCU | Cortex-A7, Dual Core 1GHz | | | | |
| Flash ROM (Bytes) | 8 GB | | | | |
| RAM (Bytes) | DDR3 1,000 MHz 1GB | | | | |
| Touch Panel | Four-wire resistor, over 10,000,000 pressing times | | | | |
| Buzzer | Multi-Tone Frequency (2K ~ 4K Hz) / 85 dB | | | | |
| Ethernet Interface | 2 Ports ² , 10 / 100 Mbps Auto sensing | | | | |
| USB | 1 Mini USB Slave Ver 2.0/1 USB Host Ver 2.0 | | | | |
| SD | SD x 1 | | | | |
| Serial COM Port | COM1 | RS-232 (supporting flow control) / RS-485 ² | | | |
| | COM2 | RS-422 / RS-485 ² | | | |
| | COM3 | RS-232 (supporting flow control) / RS-485 ² | | | |
| | COM4 | RS-422/RS-485 ² | | | |
| RTC | Built-in | | | | |
| Cooling | Natural air circulation | | | | |
| Certification | CE/UL (please use shielding Ethernet cables and magnetic rings with filters of 300 ohm / 100 MHz) | | | | |
| Waterproof | IP65 / NEMA4 / UL Type 4X (indoor use only) | | | | |
| Operation Voltage ³ | DC +24V (-15% ~ 15%) ² , supplied by Class 2 or SELV circuit (isolated from MAINS by double insulation) | | | | |
| Voltage Endurance | AC500V for 1 minute (between charging DC24 terminal and FG terminals) | | | | |
| Power Consumption ⁵ | Max. 16.08 W | Max. 21.12 W | Max. 16.08 W | Max. 21.12 W | |
| Backup Battery | 3V lithium battery CR2032 × 1 | | | | |
| Backup Battery Life | Depends on the temperature used and the conditions of usage, usually about 3 years or more at 25°C | | | | |
| Operation Temperature | 0°C ~ 50°C | | | | |
| Storage Temperature | -20°C ~ 60°C | | | | |
| Ambient Humidity | 10% ~ 90% RH (0 ~ 40°C), 10% ~ 55% RH (41 ~ 50°C), Pollution Degree 2 | | | | |
| Vibration | IEC 61131-2 compliant 5 Hz ~ 8.3 Hz = Continuous: 3.5 mm, 8.3 Hz ~ 150 Hz = Continuous: 1g | | | | |
| Shock | IEC 60068-2-27 compliant 15g peak for 11ms duration, X, Y, Z, directions for 6 times | | | | |
| Dimensions (W) x (H) x (D) mm | 317.4 x 246.4 x 52.7 | 387.7 x 295.7 x 63.5 | 317.4 x 246.4 x 52.7 | 387.7 x 295.7 x 63.5 | |
| Mounting Dimensions (W) x (H) mm | 302.7 x 228.7 | 372.4 x 283.7 | 302.7 x 228.7 | 372.4 x 283.7 | |
| Weight | 2,110 g | 3,200 g | 2,110 g | 3,200 g | |

1) The half-life of a backlight is defined as the original luminance being reduced by 50% when the maximum driving current is supplied to an HMI.

4) Built-in power isolation

5) An isolated power supply is recommended.

4) Some models are in the process of application for UL and KCC certification. For more information, please consult our distributors.

7) The value of the power consumption indicates the electrical power consumed by the HMI with no peripheral devices connected.

8) The content of this catalogue may be revised without prior notice. Please consult our distributors or download the most updated version at <http://www.deltaww.com>

Hardware Specifications

Standard HMI

| Model | | Standard General Type | | | |
|----------------------------------|--|--|---|-----------------------|------------------|
| | | DOP-105CQ | DOP-107CV | DOP-110CS | DOP-110CG |
| LCD Module | Display | 5.6" TFT LCD | 7" TFT LCD | 10.1" TFT LCD | 10.4" TFT LCD |
| | Color | 16-bit | | | |
| | Resolution (Pixels) | 320 x 234 | 800 x 480 | 1,024 x 600 | 800 x 600 |
| | Back Light | LED Back Light | | | |
| | Back Light Brightness (cd/m ²) | 200 | 400 | 300 | 300 |
| | Back Light Life (Hour) ¹¹ | 20,000 | | | |
| | Display Area | 113.28 x 84.70 mm | 154.08 x 85.92 mm | 226 x 128.7 mm | 211.2 x 158.4 mm |
| MCU | ARM Cortex-A8 (800MHz) | | | | |
| Flash ROM (Bytes) | 256 Mbytes | | | | |
| RAM (Bytes) | 256 Mbytes | | | | |
| Touch Panel | Four-wire resistor, over > 10,000,000 pressing times | | Four-wire resistor, over > 1,000,000 pressing times | | |
| Audio Output | Buzzer | Multi-Tone Frequency (2K ~ 4K Hz) / 80 dB | | | |
| | AUX | N/A | | | |
| USB | 1 USB Slave Ver 2.0 / 1 USB Host Ver 2.0 | | | | |
| SD | N/A | | | | |
| Serial COM Port | COM1 | RS-232 (supports hardware flow control) | | | |
| | COM2 | RS-232 (supports hardware flow control) / RS-485 | | | |
| | COM3 | RS-422 / RS-485 | | | |
| RTC | Built-in | | | | |
| Cooling | Natural air circulation | | | | |
| Certification | CE / UL (please equip shielding cables and line filters with capacity of 300 ohm / 100 MHz) | | | | |
| Waterproof | IP65 / NEMA4 / UL Type 4X (indoor use only)(105CQ & 110CG non UL Type 4X) | | | | |
| Operation Voltage ¹³ | DC +24V (-15% ~ +15%) ¹² , supplied by Class 2 or SELV circuit (isolated from MAINS by double insulation) | | | | |
| Voltage Endurance | AC500V for 1 minute (between charging DC24 terminal and FG terminals) | | | | |
| Power Consumption ¹⁵ | Max. 6.86 W ¹³ | Max. 8.5W ¹³ | Max. 10.4 W ¹³ | Max. 8W ¹³ | |
| Backup Battery | 3V lithium battery CR2032 × 1 | | | | |
| Backup Battery Life | Depends on the temperature used and the conditions of usage, usually about 3 years or more at 25 °C | | | | |
| Operation Temperature | 0 °C ~ 50 °C | | | | |
| Storage Temperature | -20 °C ~ 60 °C | | | | |
| Ambient Humidity | 10% ~ 90% RH (0 ~ 40 °C), 10% ~ 55% RH (41 ~ 50 °C), Pollution Degree 2 | | | | |
| Vibration | IEC 61131-2 compliant 5Hz ~ 8.3Hz = Continuous: 3.5 mm, 8.3Hz ~ 150Hz = Continuous: 1g | | | | |
| Shock | IEC 60068-2-27 compliant 15g peak for 11ms duration, X, Y, Z, directions for 6 times | | | | |
| Dimensions (W) x (H) x (D) mm | 184 x 144 x 50 | 215 x 161 x 61.2 | 272 x 200 x 61 | 299 x 224 x 46.8 | |
| Mounting Dimensions (W) x (H) mm | 172.4 x 132.4 | 196.9 x 142.9 | 261.3 x 189.3 | 285.2 x 210.2 | |
| Weight | 670g | 970g | 1,330g | 1,735g | |

1) The half-life of a backlight is defined as the original luminance being reduced by 50% when the maximum driving current is supplied to an HMI.6

2) Built-in power isolation

3) An isolated power supply is recommended.

4) Some models are in the process of application for UL and KCC certification. For more information, please consult our distributors.

5) The value of the power consumption indicates the electrical power consumed by the HMI with no peripheral devices connected.

6) The content of this catalogue may be revised without prior notice. Please consult our distributors or download the most updated version at <http://www.deltaww.com>

Standard HMI

| Model | | Standard Premium | Standard Ethernet Type (2 COM) | |
|----------------------------------|--|---|--|-------------------------|
| | | DOP-107PV | DOP-107EG | DOP-107EV |
| LCD Module | Display | 7" TFT LCD | 7" TFT LCD | 7" TFT LCD |
| | Color | 24-bit | 16-bit | |
| | Resolution (Pixels) | 800 x 480 | 800 x 600 | 800 x 480 |
| | Back Light | LED Back Light | | |
| | Back Light Brightness (cd/m ²) | 400 | 450 | 400 |
| | Back Light Life (Hour) ¹ | 20,000 | | |
| | Display Area | 154.08 x 85.92 mm | 141 x 105.75 mm | 154.08 x 85.92 mm |
| MCU | | ARM Cortex-A8 (800 MHz) | | |
| Flash ROM (Bytes) | | 256 MB | | |
| RAM (Bytes) | | 256 MB | | |
| Touch Panel | | Four-wire resistor, over > 1,000,000 pressing times | Four-wire resistor, over > 10,000,000 pressing times | |
| Audio Output | Buzzer | Multi-Tone Frequency (2K ~ 4K Hz) / 80dB | | |
| | AUX | N/A | Stereo output | N/A |
| Ethernet Interface | | 1 Port ² , 10/100 Mbps auto-sensing | | |
| USB | | 1 USB Slave Ver 2.0; 1 USB Host Ver 2.0 | | |
| SD | | N/A | SDx1 | N/A |
| Serial COM Port | COM1 | RS-232 (supports hardware flow control) ² (107PV non-isolated circuit) | | |
| | COM2 | RS-232 (supports hardware flow control) / RS-485 ² (107PV non-isolated circuit) | | |
| | COM3 | RS-422 / RS-485 ² (107PV non-isolated circuit) | | |
| RTC | | Built-in | | |
| Cooling | | Natural air circulation | | |
| Certification | | CE/UL (please use shielding Ethernet cables and magnetic rings with filters of 300 ohm / 100 MHz) | | |
| Waterproof | | IP65 / NEMA4 / UL Type 4X (indoor use only) | | |
| Operation Voltage ³ | | DC +24V (-15% ~ +15%) ² (107PV non-isolated circuit) Supplied by Class 2 or SELV circuit (isolated from MAINS by double insulation) | | |
| Voltage Endurance | | AC500V for 1 minute (between charging DC24 terminal and FG terminals) | | |
| Power Consumption ⁵ | | Max. 8.3W ³ | Max. 8.4W ³ | Max. 8.76W ³ |
| Backup Battery | | 3V lithium battery CR2032 × 1 | | |
| Backup Battery Life | | Depends on the temperature used and the conditions of usage, usually about 3 years or more at 25 °C | | |
| Operating Temperature | | 0 °C ~ 50 °C | | |
| Storage Temperature | | -20 °C ~ 60 °C | | |
| Ambient Humidity | | 10% ~ 90% RH (0 ~ 40 °C), 10% ~ 55% RH (41 ~ 50 °C), Pollution Degree 2 | | |
| Vibration | | IEC 61131-2 compliant 5 Hz ~ 8.3 Hz = Continuous: 3.5 mm, 8.3 Hz ~ 150 Hz = Continuous: 1 g | | |
| Shock | | IEC 60068-2-27 compliant 15 g peak for 11 ms duration, X, Y, Z, directions for 6 times | | |
| Dimensions (W) x (H) x (D) mm | | 196.6 x 136.6 x 38.8 | 184 x 144 x 51.5 | 215 x 161 x 61.2 |
| Mounting Dimensions (W) x (H) mm | | 186.8 x 126.8 | 172.4 x 132.4 | 196.9 x 142.9 |
| Weight | | 650 g | 800 g | 970 g |

1) The half-life of a backlight is defined as the original luminance being reduced by 50% when the maximum driving current is supplied to an HMI.

2) Built-in power isolation

3) An isolated power supply is recommended.

4) Some models are in the process of application for UL and KCC certification. For more information, please consult our distributors.

5) The value of the power consumption indicates the electrical power consumed by the HMI with no peripheral devices connected.

6) The content of this catalogue may be revised without prior notice. Please consult our distributors or download the most updated version at <http://www.deltaww.com>

Hardware Specifications

Standard HMI

| Model | | Standard Ethernet Type (3 COM) | | | |
|----------------------------------|--|---|-------------------------|------------------------|------------------------|
| | | DOP-107IV | DOP-108IG | DOP-110IS | DOP-110IG |
| LCD Module | Display | 7" TFT LCD | 8" TFT LCD | 10.1" TFT LCD | 10.4" TFT LCD |
| | Color | 16-bit | | | |
| | Resolution (Pixels) | 800 x 480 | 800 x 600 | 1024 x 600 | 800 x 600 |
| | Back Light | LED Back Light | | | |
| | Back Light Brightness (cd/m ²) | 400 | 250 | 300 | 300 |
| | Back Light Life (Hour) ¹ | 20,000 | 10,000 | 20,000 | 10,000 |
| | Display Area | 152.4 x 91.44 mm | 162 x 121.5 mm | 226 x 128.7 mm | 211.2 x 158.4 mm |
| MCU | | ARM Cortex-A8 (800MHz) | | | |
| Flash ROM (Bytes) | | 256 MB | | | |
| RAM (Bytes) | | 256 MB | | | |
| Touch Panel | | Four-wire resistor, over > 10,000,000 pressing times | | | |
| Audio Output | Buzzer | Multi-Tone Frequency (2K ~ 4K Hz) / 80 dB | | | |
| | AUX | N/A | Stereo output | | |
| Ethernet Interface | | 1 Port ² , 10/100 Mbps auto-sensing | | | |
| USB | | 1 USB Slave Ver 2.0 / 1 USB Host Ver 2.0 | | | |
| SD | | SD x 1 | | | |
| Serial COM Port | COM1 | RS-232 (supports hardware flow control) ² | | | |
| | COM2 | RS-232 (supports hardware flow control) / RS-485 ² | | | |
| | COM3 | RS-232 (supports hardware flow control) / RS-422 / RS-485 ² | | | |
| RTC | | Built-in | | | |
| Cooling | | Natural air circulation | | | |
| Certification | | CE/UL (please use shielding Ethernet cables and magnetic rings with filters of 300 ohm / 100 MHz) | | | |
| Waterproof | | IP65 / NEMA4 (indoor use only) (110IG with UL Type 4X) | | | |
| Operation Voltage ³ | | DC +24V (-15% ~ +15%) ² , supplied by Class 2 or SELV circuit (isolated from MAINS by double insulation) | | | |
| Voltage Endurance | | A500V for 1 minute (between charging DC24 terminal and FG terminals) | | | |
| Power Consumption ⁵ | | Max. 12W ³ | Max. 9.88W ³ | Max. 9.6W ³ | Max. 9.6W ³ |
| Backup Battery | | 3V lithium battery CR2032 x 1 | | | |
| Backup Battery Life | | Depends on the temperature used and the conditions of usage, usually about 3 years or more at 25°C | | | |
| Operation Temperature | | 0°C ~ 50°C | | | |
| Storage Temperature | | -20°C ~ 60°C | | | |
| Ambient Humidity | | 10% ~ 90% RH (0 ~ 40°C), 10% ~ 55% RH (41 ~ 50°C), Pollution Degree 2 | | | |
| Vibration | | IEC 61131-2 compliant 5 Hz ~ 8.3 Hz = Continuous: 3.5 mm, 8.3 Hz ~ 150 Hz = Continuous: 1g | | | |
| Shock | | IEC 60068-2-27 compliant 15g peak for 11ms duration, X, Y, Z, directions for 6 times | | | |
| Dimensions (W) x (H) x (D) mm | | 215 x 161 x 61.2 | 227.1 x 174.1 x 61 | 272.6 x 200.6 x 54 | 299 x 224 x 46.8 |
| Mounting Dimensions (W) x (H) mm | | 196.9 x 142.9 | 219.4 x 166.5 | 261.3 x 189.3 | 285.2 x 210.2 |
| Weight | | 970g | 1,226g | 1,130g | 1,600g |

1) The half-life of a backlight is defined as the original luminance being reduced by 50% when the maximum driving current is supplied to an HMI.6

2) Built-in power isolation

3) An isolated power supply is recommended.

4) Some models are in the process of application for UL and KCC certification. For more information, please consult our distributors.

5) The value of the power consumption indicates the electrical power consumed by the HMI with no peripheral devices connected.

6) The content of this catalogue may be revised without prior notice. Please consult our distributors or download the most updated version at <http://www.deltaww.com>

Basic HMI

| Model | | Simple Type | Basic Type | |
|----------------------------------|---|--|------------------------|-------------------|
| | | DOP-103SQ | DOP-103BQ | DOP-107BV |
| LCD Module | Display | 4.3" TFT LCD | 4.3" TFT LCD | 7" TFT LCD |
| | Color | 16-bit | | |
| | Resolution (Pixels) | 480 x 272 | 480 x 272 | 800 x 480 |
| | Back Light | LED Back Light | | |
| | IPS | Yes | N/A | N/A |
| | Back Light Brightness (cd/m ²) | 400 | | |
| | Back Light Life (Hour) ¹ | 20,000 | | |
| | Display Area | 95.04 x 53.856 mm | 95.04 x 53.856 mm | 154.08 x 85.92 mm |
| MCU | ARM Cortex-A8 (800MHz) | | | |
| Flash ROM (Bytes) | 256 MB | | | |
| RAM (Bytes) | 256 MB | | | |
| Touch Panel | Four-wire resistor, over > 10,000,000 pressing times | | | |
| Audio Output | Buzzer | Multi-Tone Frequency (2K ~ 4K Hz) / 80 dB | | |
| | AUX | N/A | | |
| Ethernet Interface | N/A | | | |
| USB | 1 USB Slave Ver 2.0 / 1 USB Host Ver 2.0 | | | |
| SD | N/A | | | |
| Serial COM Port | COM1 | RS-232 (supports hardware flow control) / RS-485 | | |
| | COM2 | RS-422 / RS-485 | | |
| | COM3 | N/A | | |
| RTC | Built-in | | | |
| Cooling | Natural air circulation | | | |
| Certification | CE / UL (please equip shielding cables and line filters with capacity of 300 ohm / 100 MHz) | | | |
| Waterproof | IP65 / NEMA4 / UL Type 4X (indoor use only) | | | |
| Operation Voltage ³ | DC +24V (-15% ~ +15%) ² , supplied by Class 2 or SELV circuit (isolated from MAINS by double insulation) | | | |
| Voltage Endurance | AC500V for 1 minute (between charging DC24 terminal and FG terminals) | | | |
| Power Consumption ⁵ | Max. 5.67W ³ | Max. 5.67W ³ | Max. 8.6W ³ | |
| Backup Battery | 3V lithium battery CR2032 × 1 | | | |
| Backup Battery Life | Depends on the temperature used and the conditions of usage, usually about 3 years or more at 25 °C | | | |
| Operation Temperature | 0 °C ~ 50 °C | | | |
| Storage Temperature | -20 °C ~ 60 °C | | | |
| Ambient Humidity | 10% ~ 90% RH (0 ~ 40 °C), 10% ~ 55% RH (41 ~ 50 °C), Pollution Degree 2 | | | |
| Vibration | IEC 61131-2 compliant 5Hz ~ 8.3Hz = Continuous: 3.5 mm, 8.3Hz ~ 150Hz = Continuous: 1g | | | |
| Shock | IEC 60068-2-27 compliant 15g peak for 11ms duration, X, Y, Z, directions for 6 times | | | |
| Dimensions (W) x (H) x (D) mm | 129 x 103 x 37.8 | 137 x 103 x 37.1 | 215 x 161 x 35.5 | |
| Mounting Dimensions (W) x (H) mm | 118.8 x 92.8 | 118.8 x 92.8 | 196.9 x 142.9 | |
| Weight | 280g | 280g | 700g | |

1) The half-life of a backlight is defined as the original luminance being reduced by 50% when the maximum driving current is supplied to an HMI.6

2) Built-in power isolation

3) An isolated power supply is recommended.

4) Some models are in the process of application for UL and KCC certification. For more information, please consult our distributors.

5) The value of the power consumption indicates the electrical power consumed by the HMI with no peripheral devices connected.

6) The content of this catalogue may be revised without prior notice. Please consult our distributors or download the most updated version at <http://www.deltaww.com>

Hardware Specifications

Basic HMI

| Model | | Basic Ethernet Type | |
|----------------------------------|--|---|---|
| | | DOP-103DQ | DOP-107DV |
| LCD Module | Display | 4.3" TFT LCD | 7" TFT LCD |
| | Color | 16-bit | |
| | Resolution (Pixels) | 480 x 272 | 800 x 480 |
| | Back Light | LED Back Light | |
| | IPS | Yes | N/A |
| | Back Light Brightness (cd/m ²) | 400 | |
| | Back Light Life (Hour) ¹ | 10,000 | 20,000 |
| | Display Area | 95.04 x 53.856 mm | 154.08 x 85.92 mm |
| MCU | | ARM Cortex-A8 (800 MHz) | |
| Flash ROM (Bytes) | | 256 MB | |
| RAM (Bytes) | | 512 MB | 256 MB |
| Touch Panel | | Four-wire resistor, over > 10,000,000 pressing times | Four-wire resistor, over > 1,000,000 pressing times |
| Audio Output | Buzzer | Multi-Tone Frequency (2K ~ 4K Hz) / 80dB | |
| | AUX | N/A | |
| Ethernet Interface | | 1 Port ² , 10/100 Mbps auto-sensing | |
| USB | | 1 USB Slave Ver 2.0 / 1 USB Host Ver 2.0 | |
| SD | | N/A | |
| Serial COM Port | COM1 | RS-232 (supports hardware flow control) ² /RS-485 ² (107DV non-isolated circuit) | |
| | COM2 | RS-422/RS-485 ² (107DV non-isolated circuit) | |
| | COM3 | N/A | |
| RTC | | Built-in | |
| Cooling | | Natural air circulation | |
| Certification | | CE/UL (please use shielding Ethernet cables and magnetic rings with filters of 300 ohm / 100 MHz) | |
| Waterproof | | IP65 / NEMA4 / UL Type 4X (indoor use only) | |
| Operation Voltage ³ | | DC +24V (-15% ~ +15%) ² (107DV non-isolated circuit), supplied by Class 2 or SELV circuit (isolated from MAINS by double insulation) | |
| Voltage Endurance | | AC500V for 1 minute (between charging DC24 terminal and FG terminals) | |
| Power Consumption ⁵ | | Max. 5.8W ³ | Max. 8.8W ³ |
| Backup Battery | | 3V lithium battery CR2032 × 1 | |
| Backup Battery Life | | Depends on the temperature used and the conditions of usage, usually about 3 years or more at 25°C | |
| Operation Temperature | | 0°C ~ 50°C | |
| Storage Temperature | | -20°C ~ 60°C | |
| Ambient Humidity | | 10% ~ 90% RH (0 ~ 40°C), 10% ~ 55% RH (41 ~ 50°C), Pollution Degree 2 | |
| Vibration | | IEC 61131-2 compliant 5Hz ~ 8.3Hz = Continuous: 3.5 mm, 8.3Hz ~ 150Hz = Continuous: 1g | |
| Shock | | IEC 60068-2-27 compliant 15g peak for 11ms duration, X, Y, Z, directions for 6 times | |
| Dimensions (W) x (H) x (D) mm | | 129 x 103 x 37.8 | 215 x 161 x 35.5 |
| Mounting Dimensions (W) x (H) mm | | 118.8 x 92.8 | 196.9 x 142.9 |
| Weight | | 280g | 700g |

1) The half-life of a backlight is defined as the original luminance being reduced by 50% when the maximum driving current is supplied to an HMI.6

2) Built-in power isolation

3) An isolated power supply is recommended.

4) Some models are in the process of application for UL and KCC certification. For more information, please consult our distributors.

5) The value of the power consumption indicates the electrical power consumed by the HMI with no peripheral devices connected.

6) The content of this catalogue may be revised without prior notice. Please consult our distributors or download the most updated version at <http://www.deltaww.com>

Handheld HMI

| Model | | Handheld HMI | | | |
|--------------------------------|---|--|-----------------------------|----------------|----------------|
| | | DOP-107HS4xx | DOP-107HE4xx | DOP-107HE4xxZM | DOP-107HE47xZD |
| LCD Module | Display | 7" TFT LCD | | | |
| | Color | 16-bit | | | |
| | Resolution (Pixels) | 800 x 480 | | | |
| | Back Light | LED Back Light | | | |
| | Back Light Brightness (cd/m ²) | 400 | 450 | 450 | |
| | Back Light Life (Hour) ¹ | 20,000 | | | |
| | Display Area | 154.08 x 85.92 mm | | | |
| MCU | ARM Cortex-A8 (800MHz) | | | | |
| Flash ROM (Bytes) | 256 MB | | | | |
| RAM (Bytes) | 256 MB | | | | |
| Touch Panel | Four-wire resistor, over > 10,000,000 pressing times | | | | |
| Buzzer | Multi-Tone Frequency (2K ~ 4KHz) / 80 dB | | | | |
| Ethernet Interface | N/A | 1 Port ² , 10/100 Mbps auto-sensing | | | |
| USB | 1 USB Slave Ver 2.0 | | | | |
| SD | SD/SDHC | | | | |
| Serial COM Port/Communication | RS-422 /RS-485 | N/A | | | |
| Emergency Stopswitch | B contact x 2 | | A contact x 1/B contact x 1 | | |
| | Rated voltage: < DC 30V; Maximum rated current: 1A; Minimum allowable load: DC 5V / 1 mA Complies with IEC60947-5-1, EN60947-5-1, IEC60947-5-5, EN60947-5-5, UL 508, CSA C22.2 No.14, GB 14085.5 | | | | |
| 3-Position Operation Switch | A contact x 1 | | | | |
| | Rated voltage: < DC 30V; Maximum rated current: 700 mA; Minimum allowable load: DC 3V / 5 mA Complies with EN/IEC60947-5-8, IEC60947-5-1, EN60947-5-1, JIS C8201-5-1, UL508, CSA C22.2 NO.14 Applicable standards for use with ISO12100-1 & -2/EN12100-1 & -2, IEC60204-1/EN60204-1, ISO11161/ prEN11161, ISO10218/EN775, ANSI/RIA R15.06, ANSI B11.19 | | | | |
| MPG | DOP-107HE42x, DOP-107HS42x, DOP-107HE42xZM do not support MPG Rated voltage: < DC 24V Resolution: 50(P/R) Output waveform: square wave; Output phase: A, B Phase difference between A and B: 90° ± 45° Maximum frequency response: 200 Hz | | | | |
| Auxiliary Keyboard | 15 Function Keys | | 21 Function Keys | | |
| Cable Length | 5 m (when end of model name = 5) 10 m (when end of model name = A) | | | | |
| Calendar | Built-in | | | | |
| Cooling Method | Natural cooling | | | | |
| Certification | CE (please use shielding Ethernet cables and magnetic rings with filters of 300 ohm / 100 MHz) | | | | |
| Protection Rating | IP54 | | | | |
| Operating Voltage ³ | DC +24V (-15% ~ +15%) ² , supplied by SELV circuits (isolated from MAINS by double insulation) | | | | |
| Voltage Endurance | AC500V for one minute (between DC24 and FG terminals) | | | | |
| Power Consumption ⁵ | 4.896 W ³ | | | | |
| Backup Battery | 3V lithium battery CR2450 × 1 | | | | |
| Backup Battery Life | About 5 years or more at 25 °C (77°F)(subject to operation temperature and condition) | | | | |
| Operation Temperature | 0 °C ~ 40 °C | | | | |
| Storage Temperature | -10 °C ~ 60 °C | | | | |
| Operating Environment | 10% ~ 90% RH (0 ~ 40 °C), 10% ~ 55% RH (41 ~ 50 °C), Pollution Degree 2 | | | | |
| Vibration | IEC 61131-2 compliant 5Hz ~ 8.3Hz = Continuous: 3.5 mm, 8.3Hz ~ 150Hz = Continuous: 1g | | | | |
| Shock | IEC 60068-2-27 compliant 15g peak for 11ms duration, X, Y, Z, directions for 6 times | | | | |
| Dimensions (W) x (H) x (D) mm | 257.4 x 170.3 x 71.8 (emergency stop switch and hook included) | | | | |
| Weight | 750 g (cable excluded) | | | | |

1) The half-life of a backlight is defined as the original luminance being reduced by 50% when the maximum driving current is supplied to an HMI.6

2) Built-in power isolation

3) An isolated power supply is recommended.

4) Some models are in the process of application for UL and KCC certification. For more information, please consult our distributors.

5) The value of the power consumption indicates the electrical power consumed by the HMI with no peripheral devices connected.

6) The content of this catalogue may be revised without prior notice. Please consult our distributors or download the most updated version at <http://www.deltaww.com>

Model Description

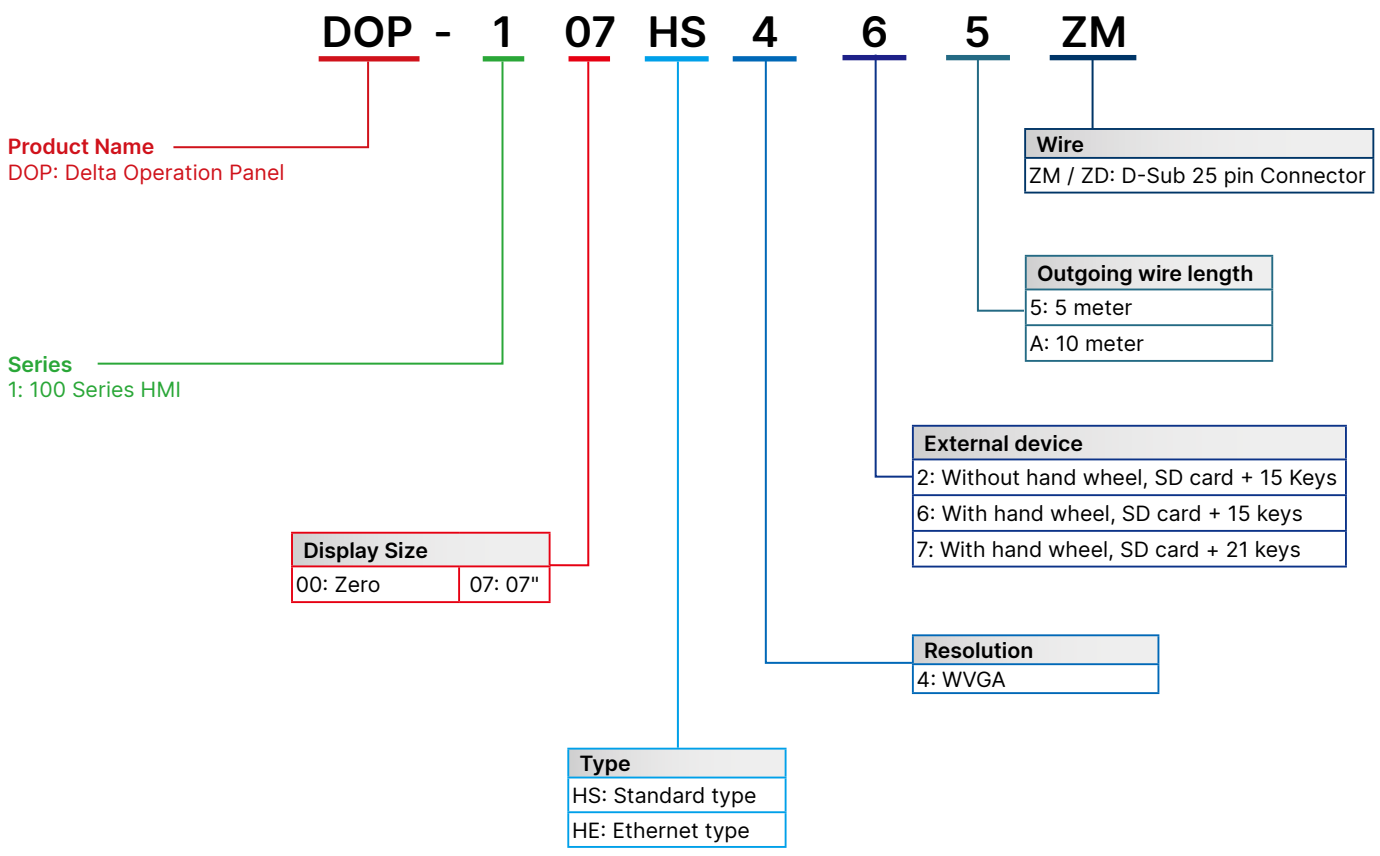
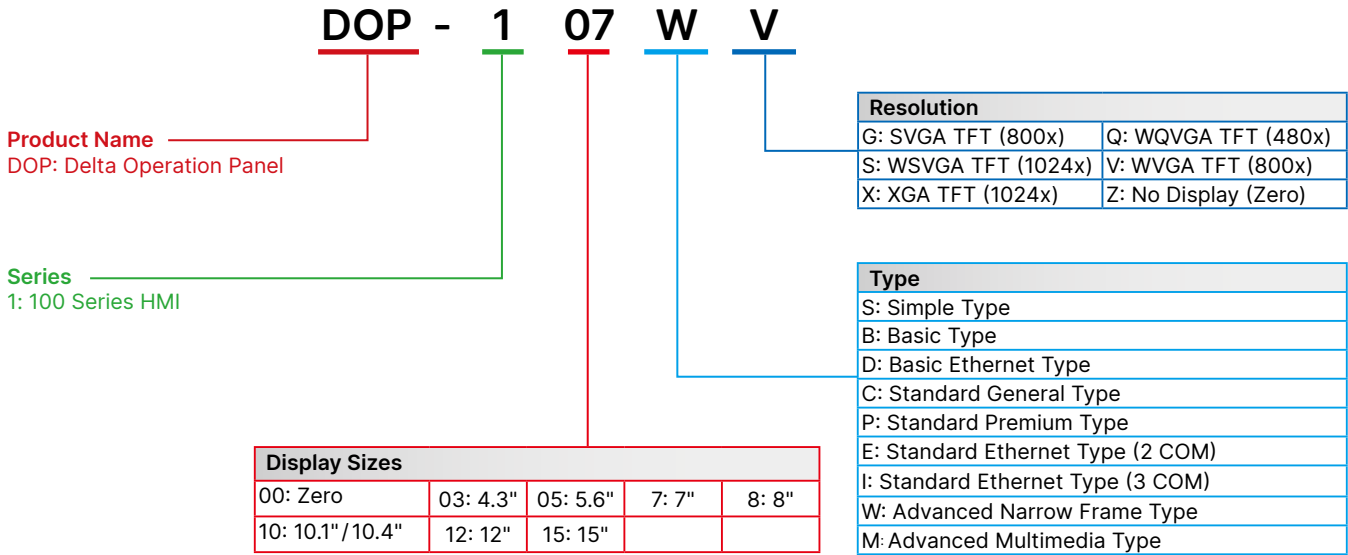

Dimensions Unit: mm (inches)

•DOP-103WQ

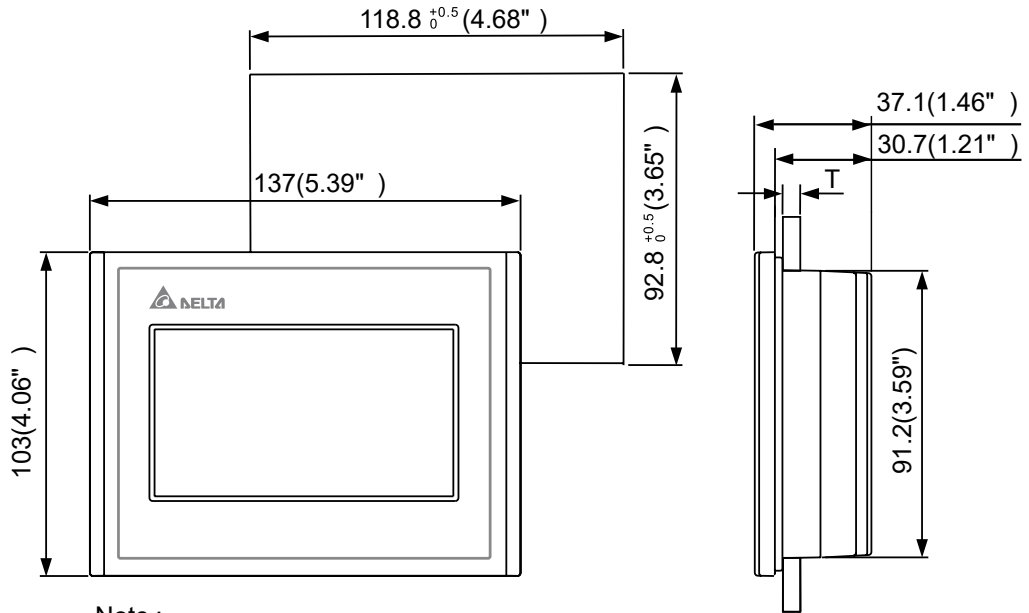

Note :
T=1.6mm~3mm(0.063"~0.12")

•DOP-107WV

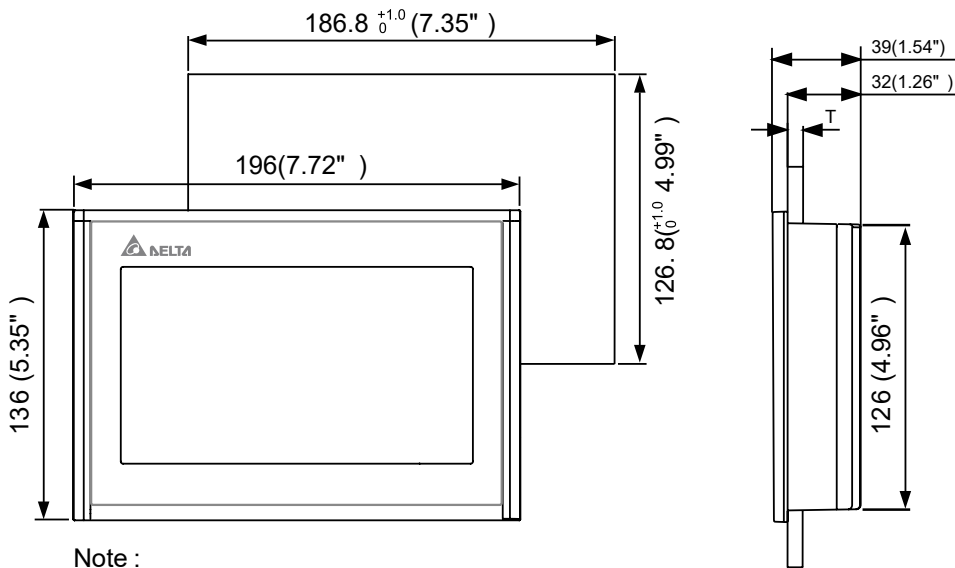

Note :
T=1.6mm~6mm(0.063"~0.24")

Dimensions Unit: mm (inches)

•DOP-110WS

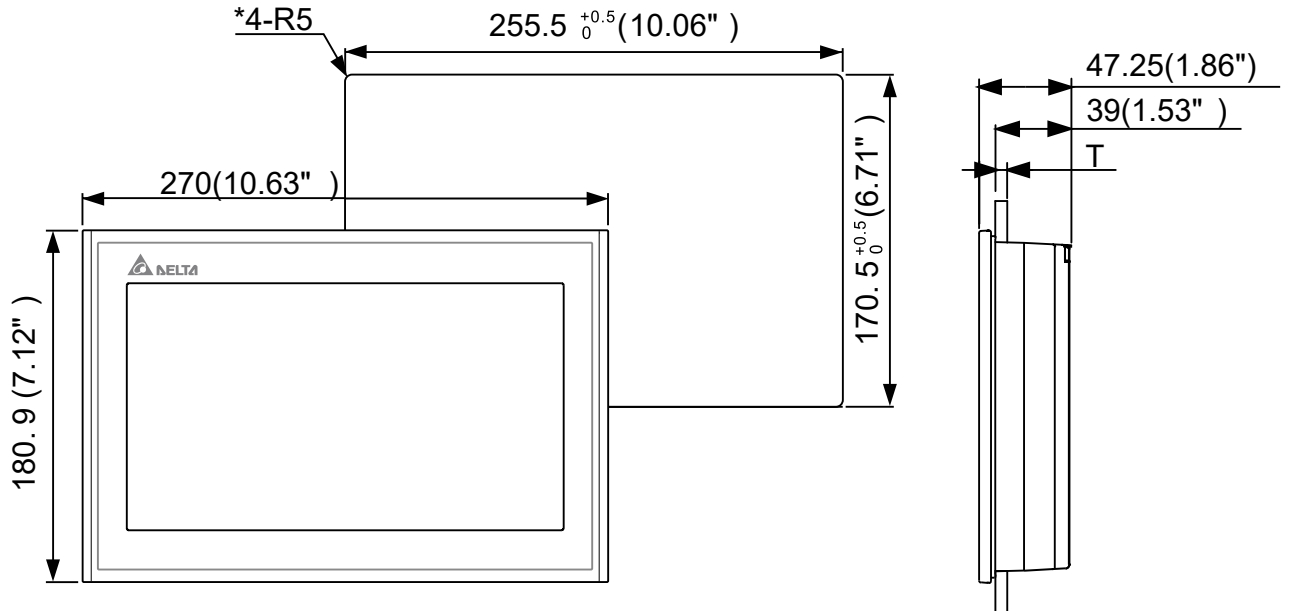

Note :
T=1.6mm~6mm(0.063"~0.24")

•DOP-112MX / DOP-112WX

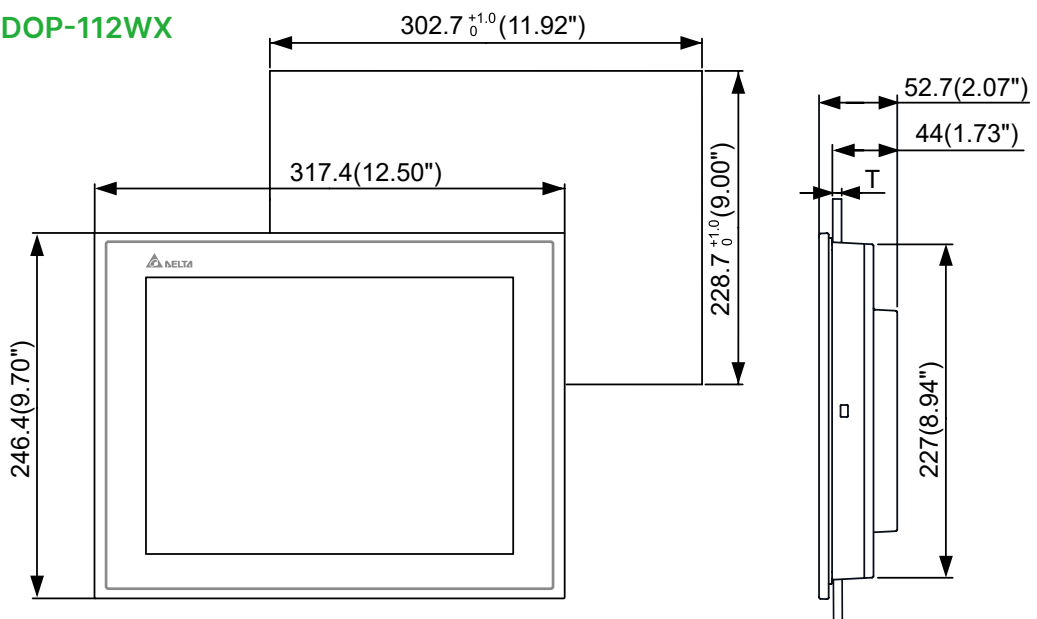

Note:
T=1.6 mm ~ 6 mm(0.063" ~ 0.24")

Dimensions Unit: mm (inches)

•DOP-115MX / DOP-115WX

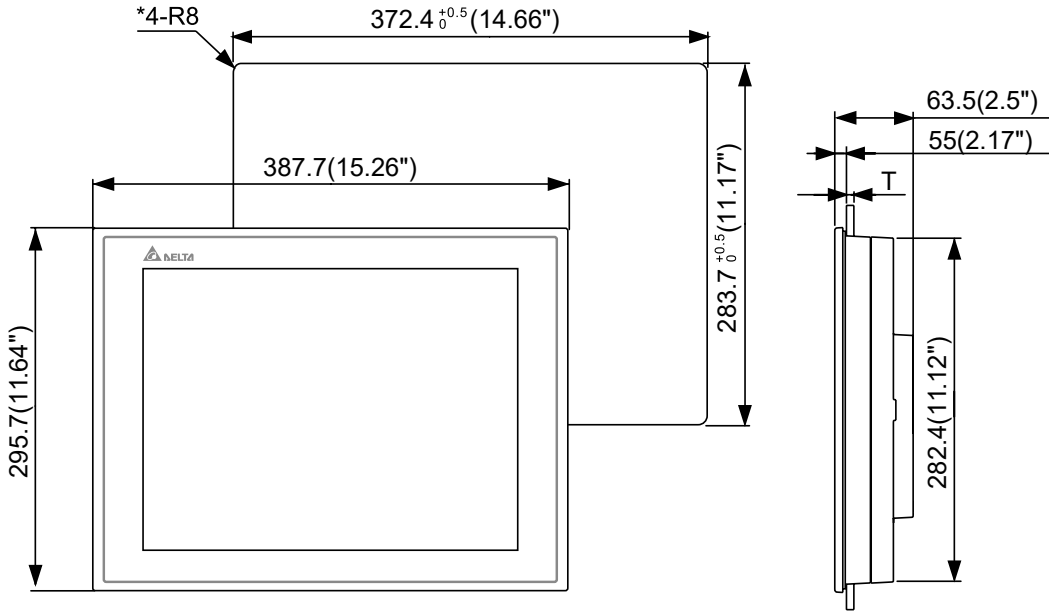

Note:
T=1.6 mm ~ 6 mm(0.063" ~ 0.24")

•DOP-105CQ

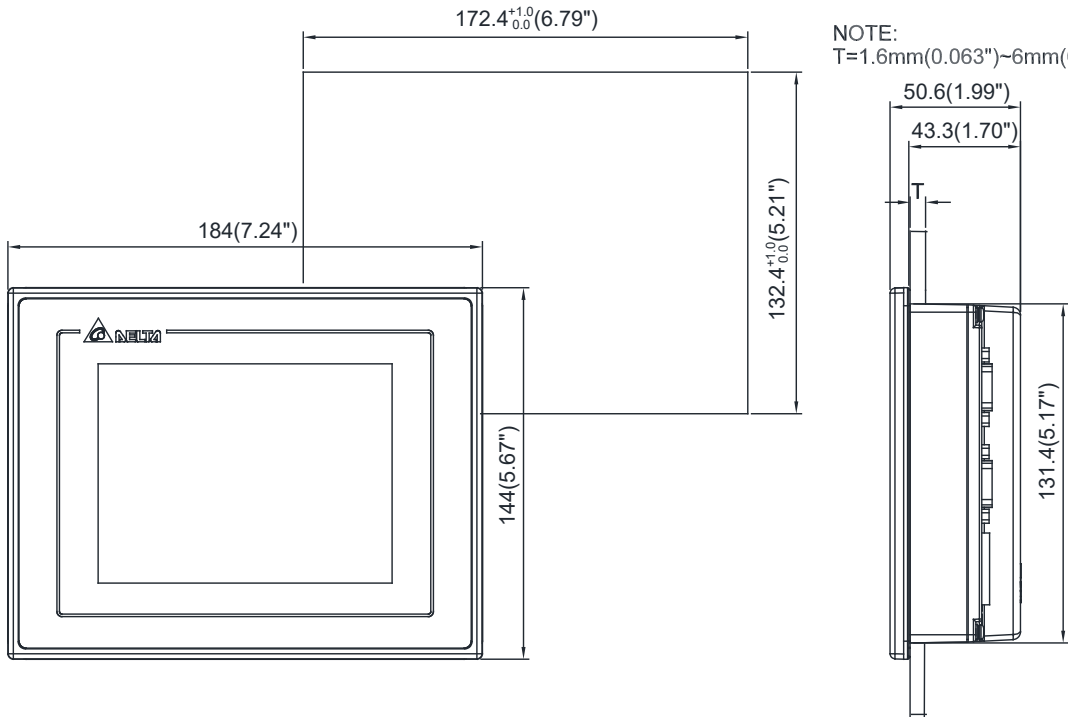

NOTE:
T=1.6mm(0.063")~6mm(0.24")

Dimensions Unit: mm (inches)

•DOP-107CV

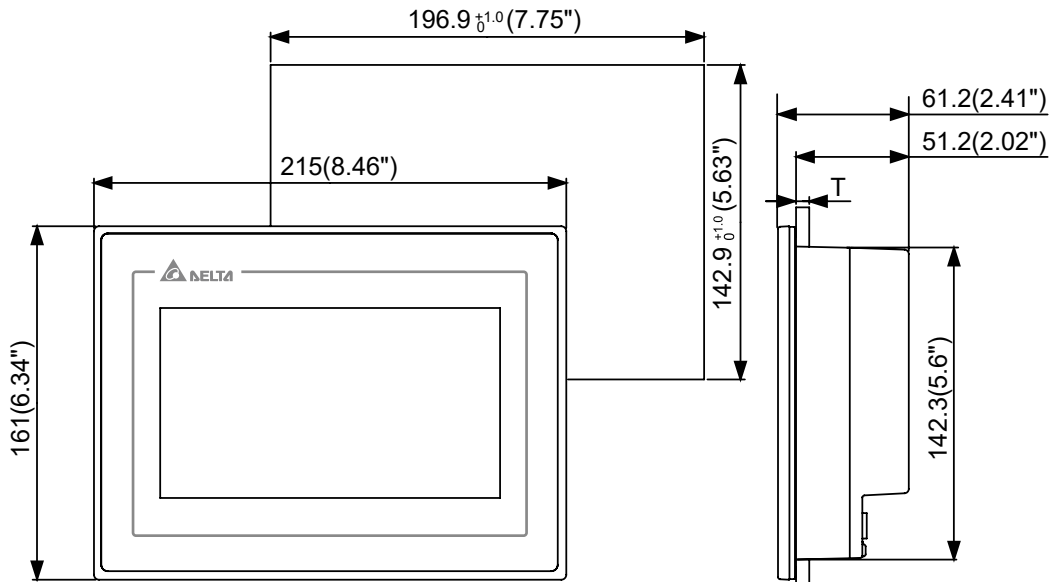

Note:
T=1.6 mm ~ 6 mm(0.063" ~ 0.24")

•DOP-110CS

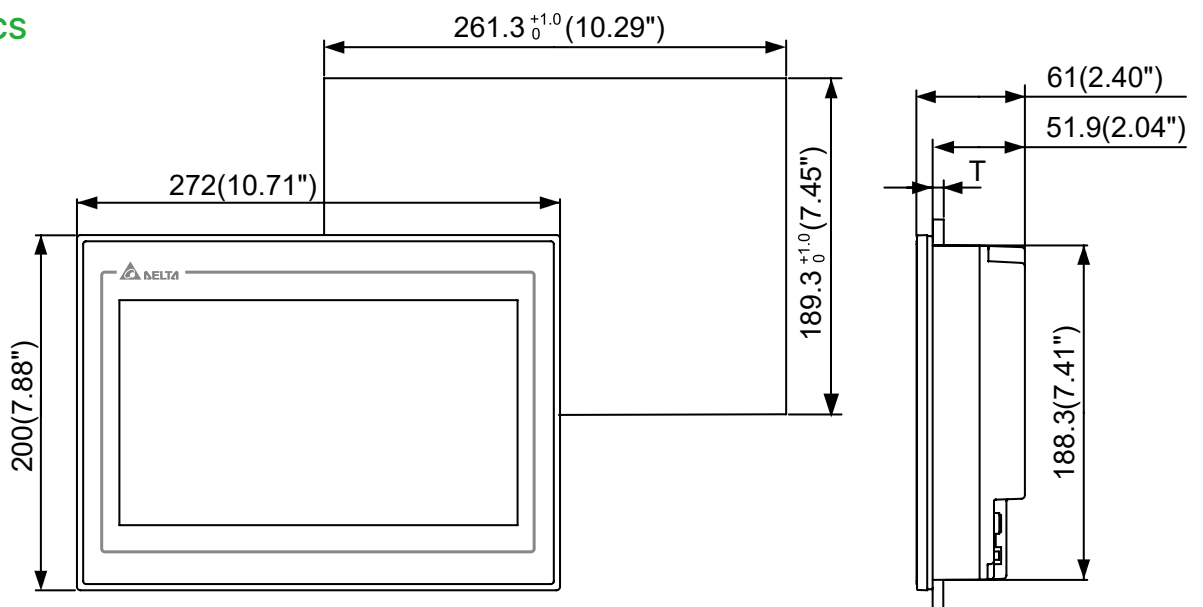

Note:
T=1.6 mm ~ 6 mm(0.063" ~ 0.24")

Dimensions Unit: mm (inches)

•DOP-110CG

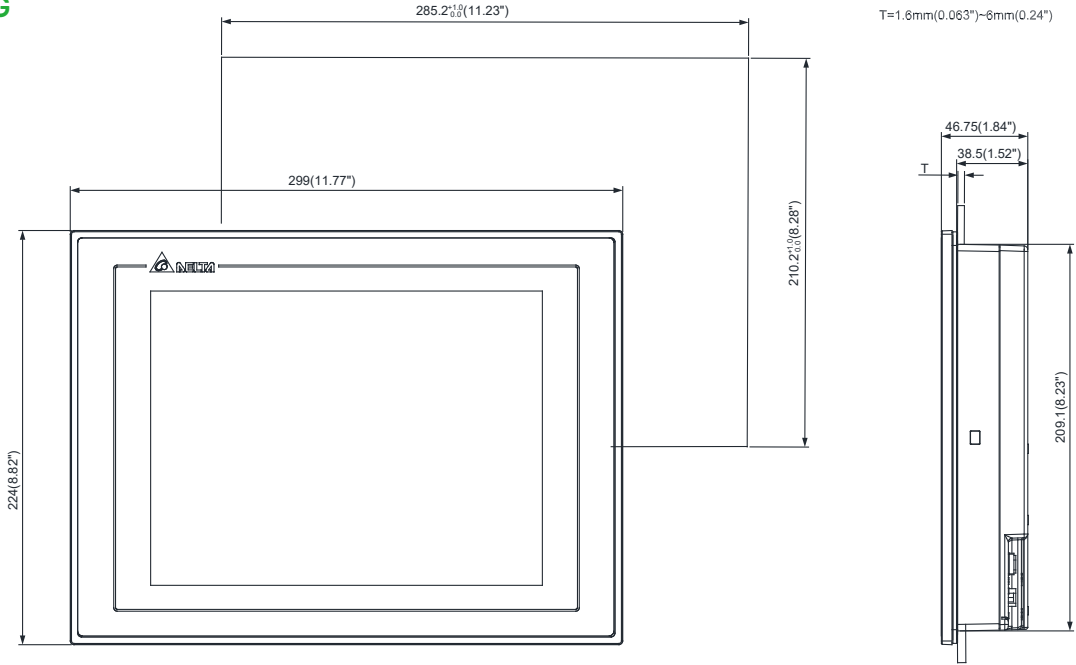

•DOP-107PV

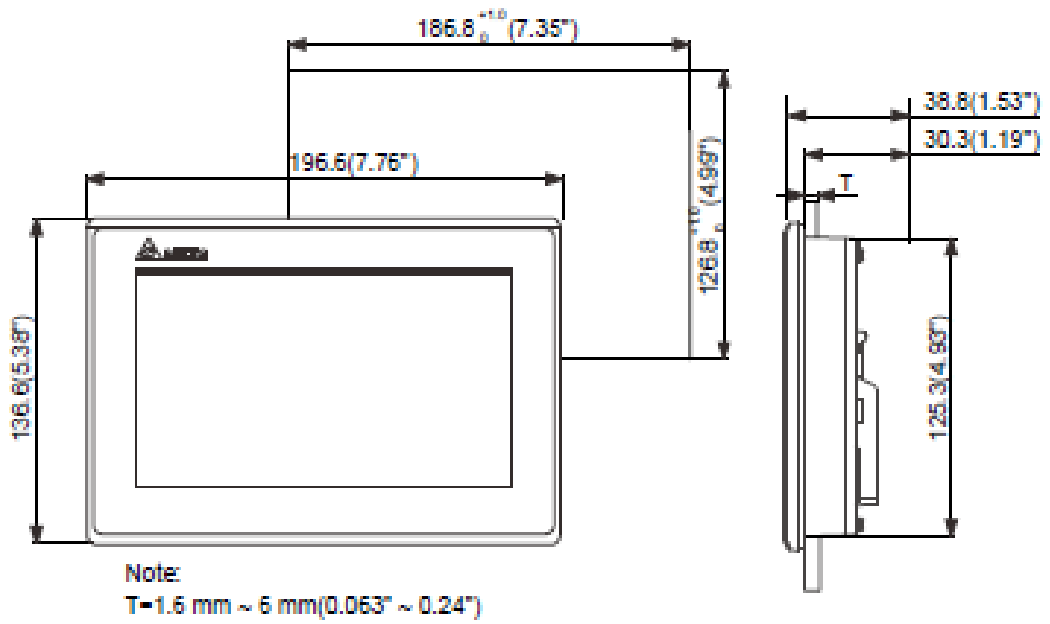

Dimensions Unit: mm (inches)

•DOP-107EG

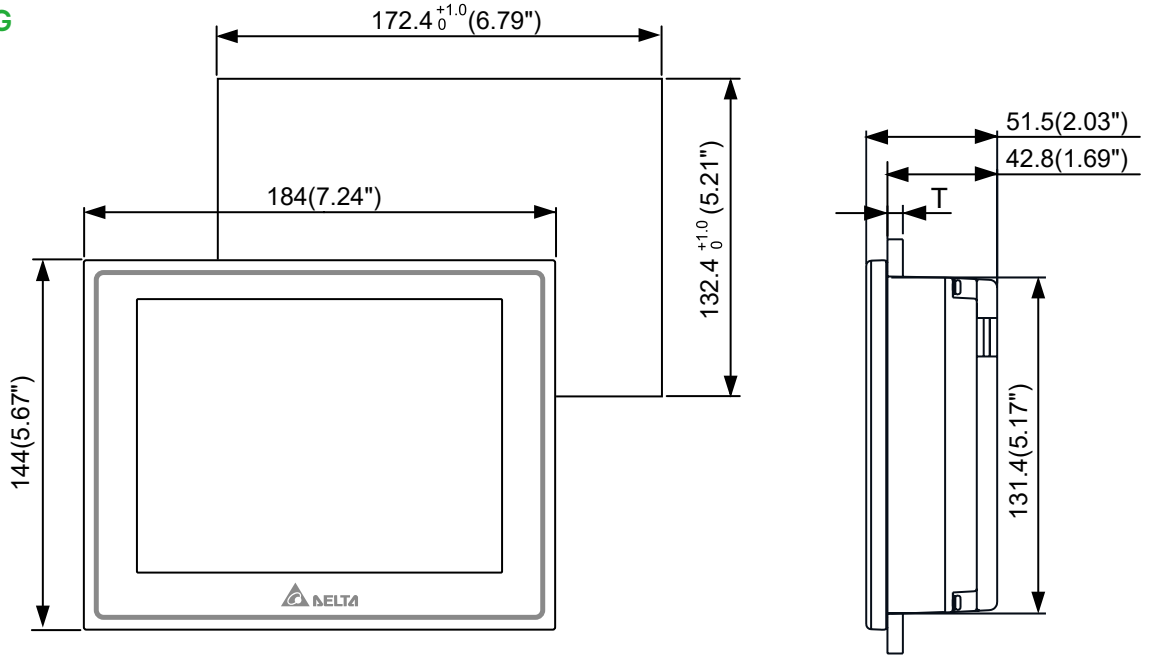

Note:
T=1.6 mm ~ 6 mm(0.063" ~ 0.24")

•DOP-107EV

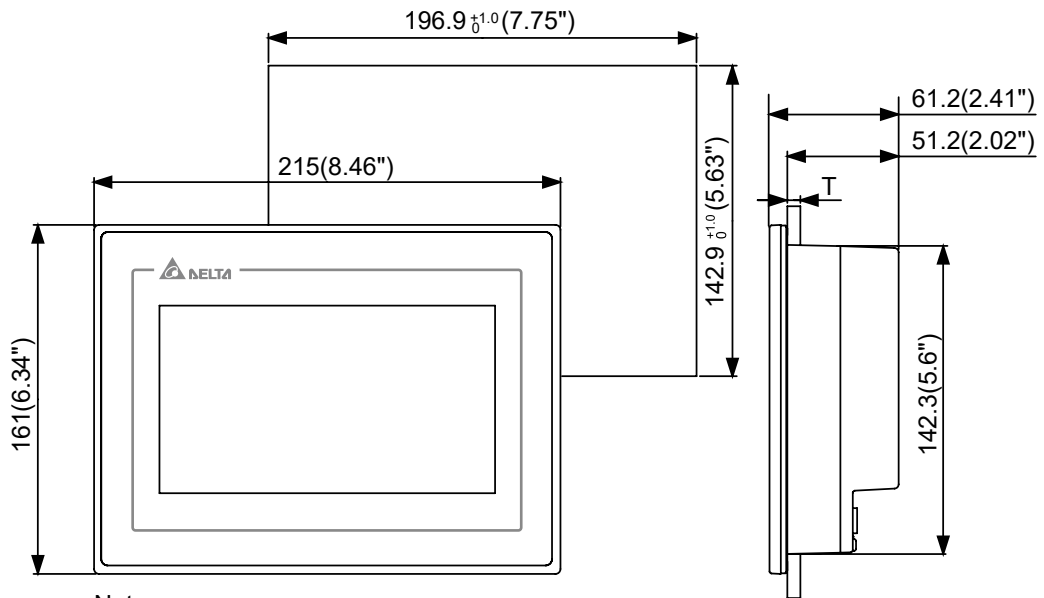

Note:
T=1.6 mm ~ 6 mm(0.063" ~ 0.24")

Dimensions Unit: mm (inches)

•DOP-107IV

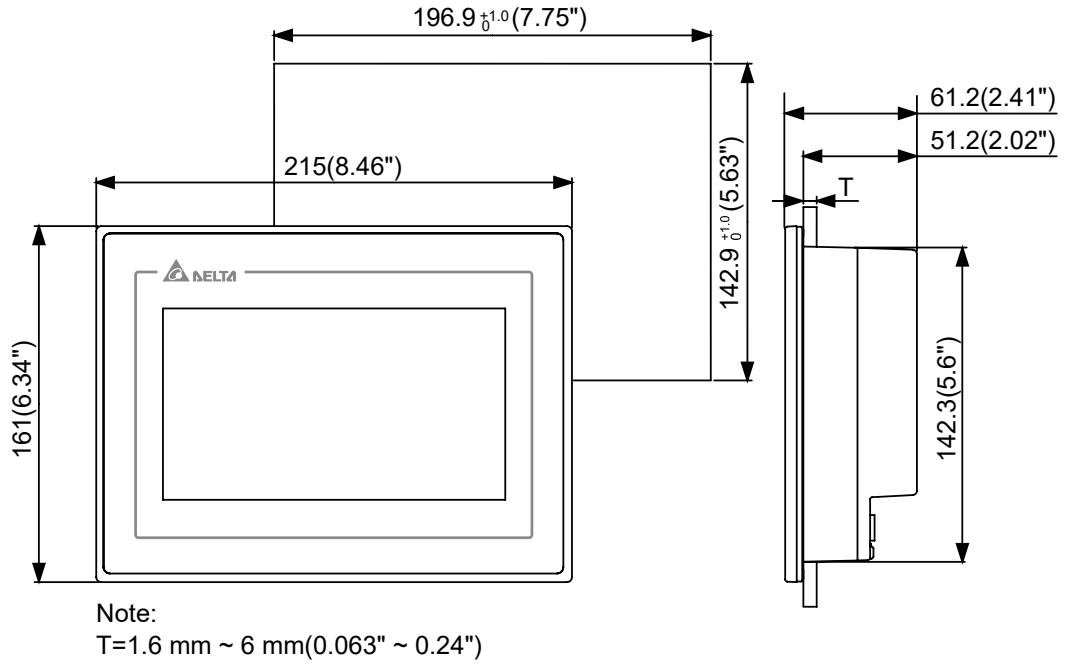

•DOP-108IG

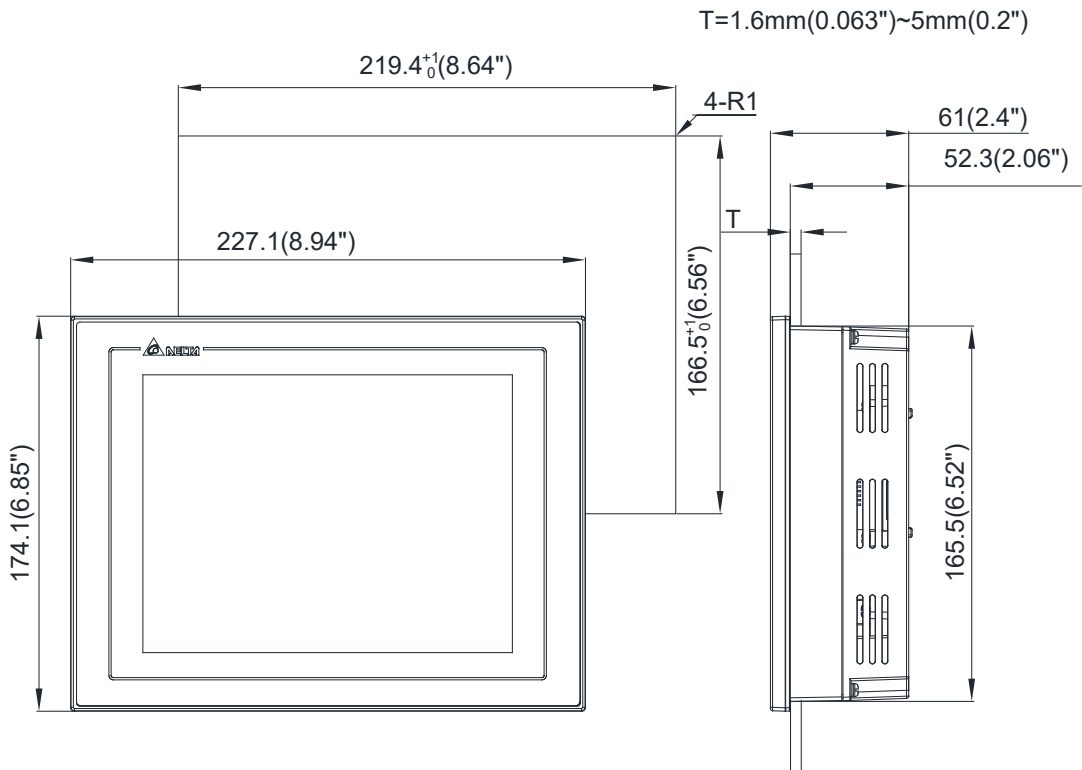

Dimensions Unit: mm (inches)

•DOP-110IS

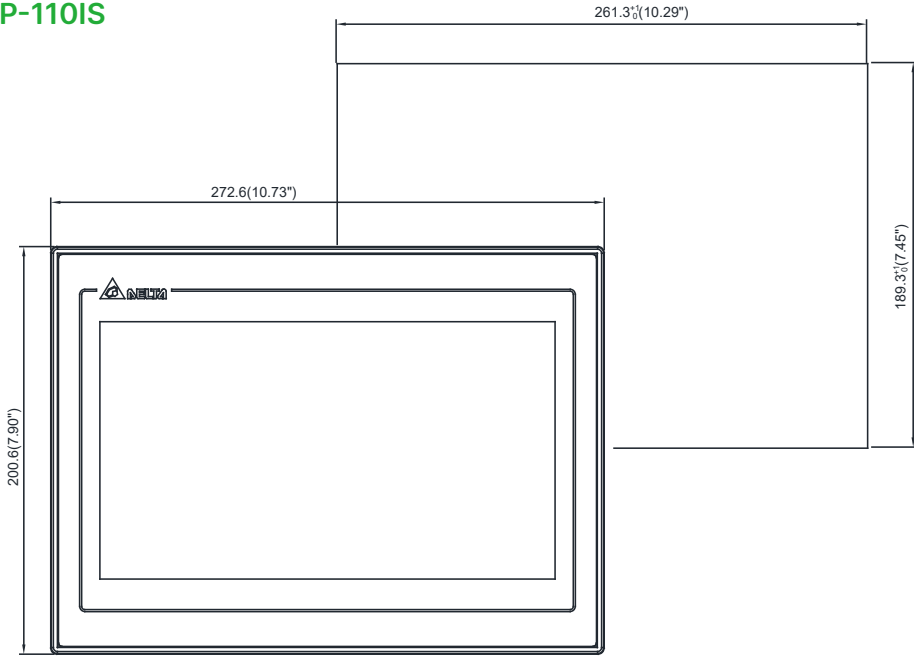

Note:
T=1.6mm(0.063")~6mm(0.24")

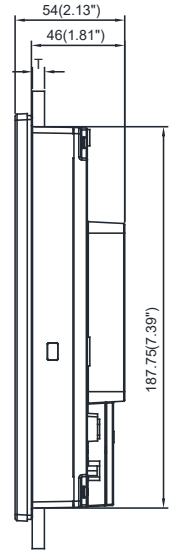

•DOP-110IG

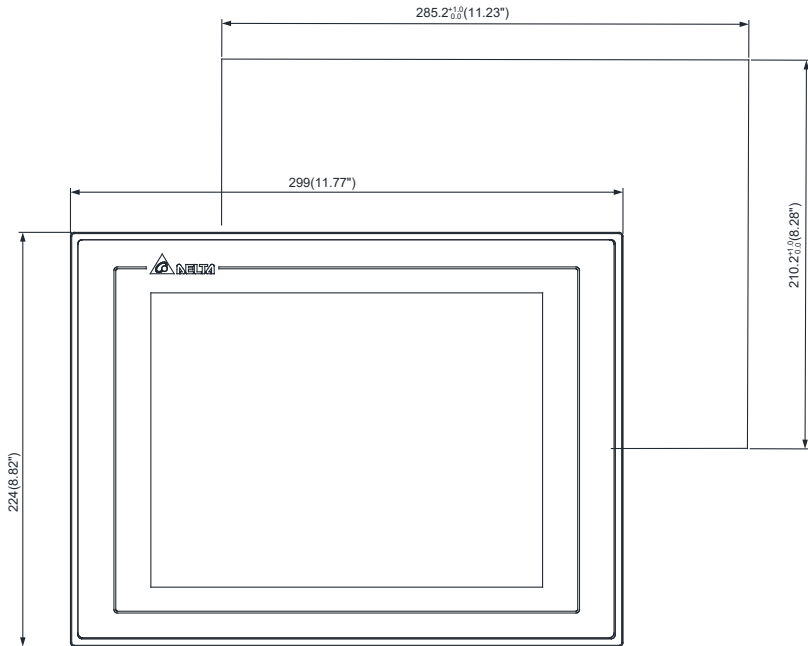

T=1.6mm(0.063")~6mm(0.24")

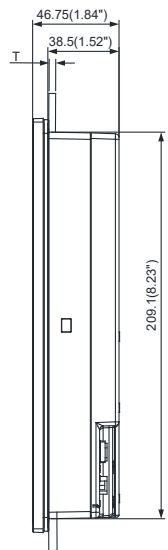

Dimensions Unit: mm (inches)

•DOP-103SQ

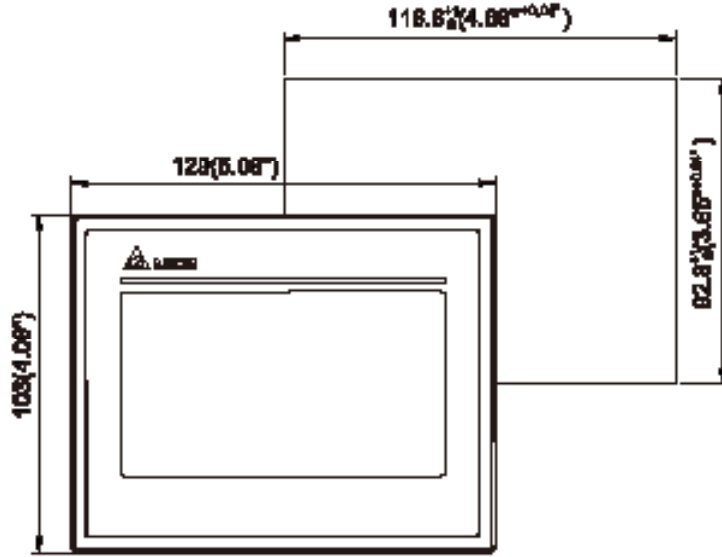

NOTE:
 $T=1.6\text{mm}(0.063")\sim 3\text{mm}(0.12")$



•DOP-103BQ

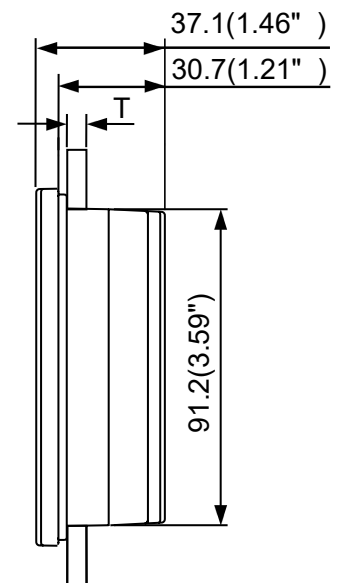
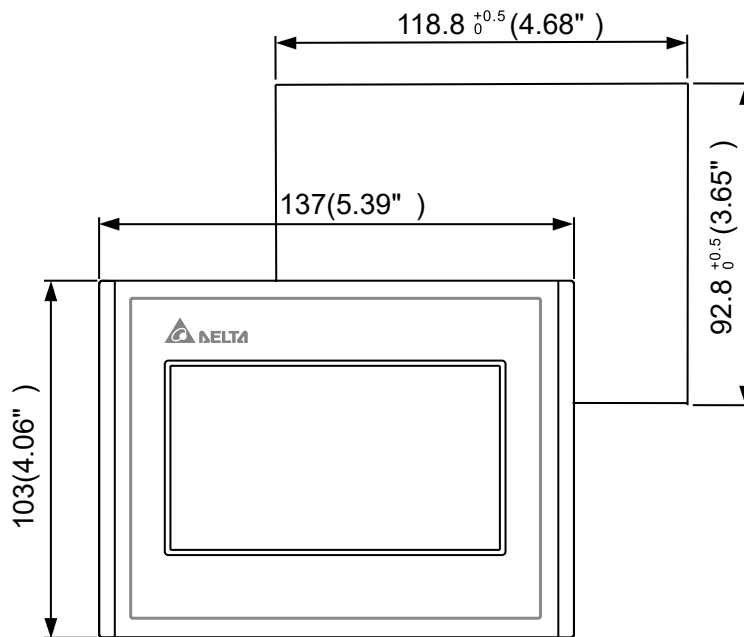

Note :
 $T=1.6\text{mm}\sim 3\text{mm}(0.063"\sim 0.12")$

Dimensions Unit: mm (inches)

•DOP-107BV

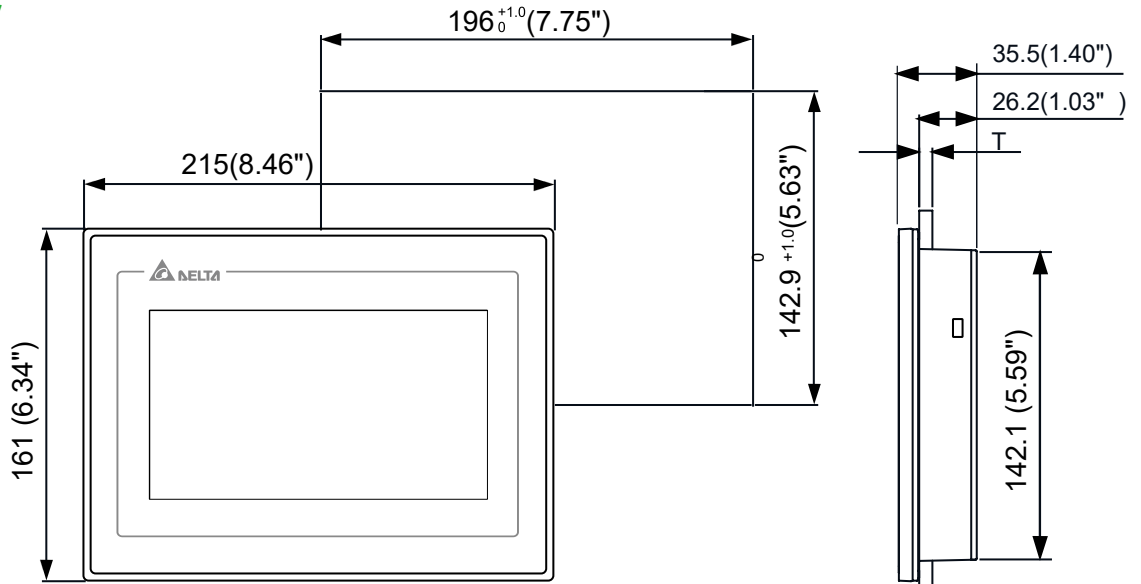

Note:
T=1.6 mm~6 mm(0.06"~0.24")

•DOP-103DQ

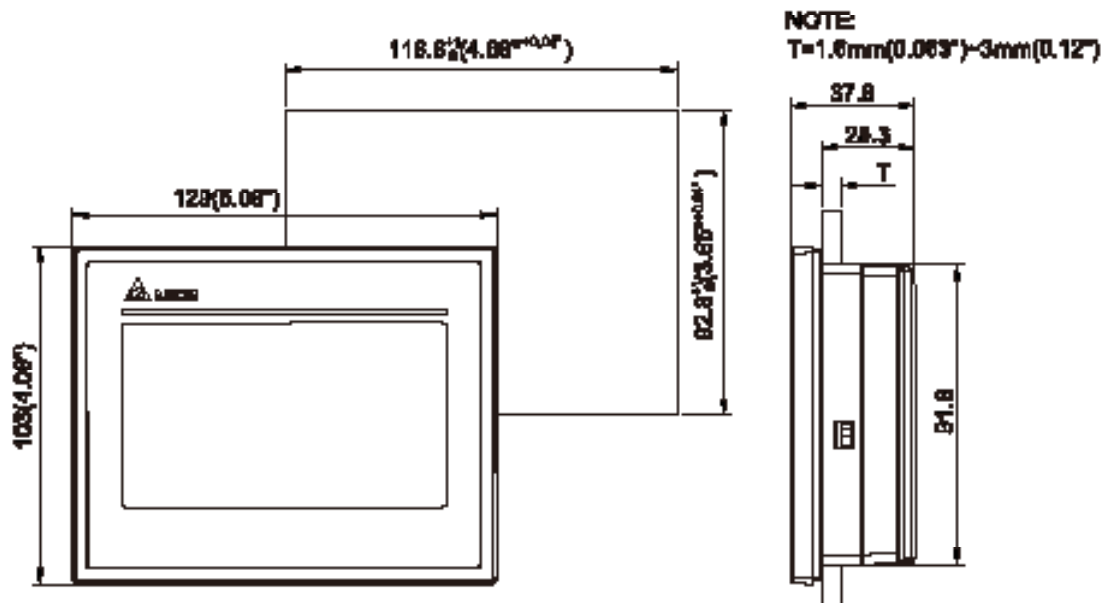

Dimensions Unit: mm (inches)

•DOP-107DV

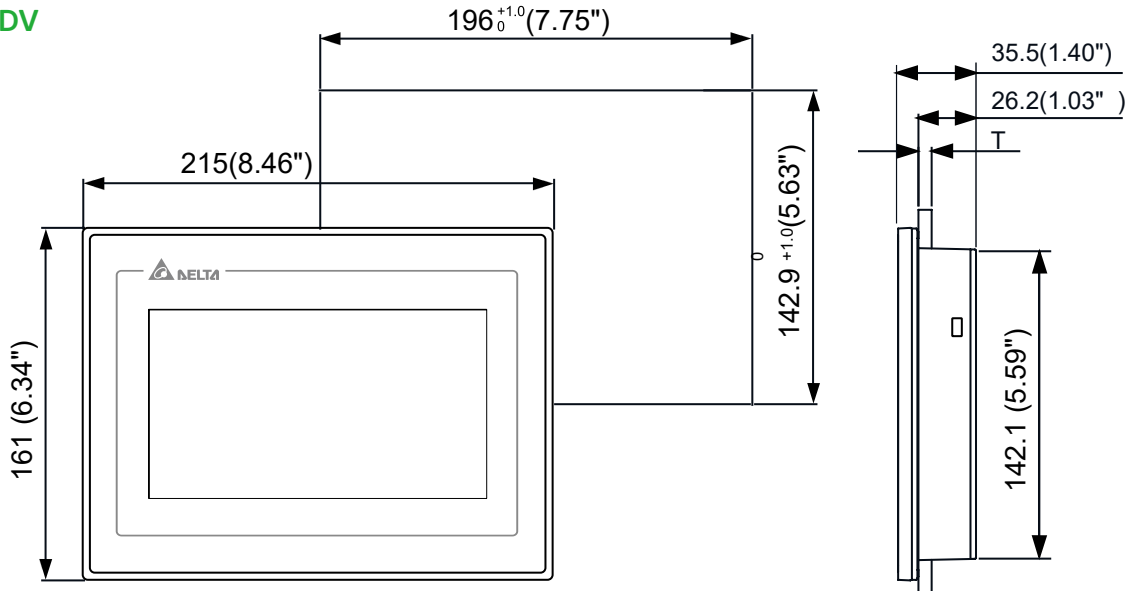

Note:
T=1.6 mm~6 mm(0.06"~0.24")

•DOP-107HS4 / DOP-107HE4

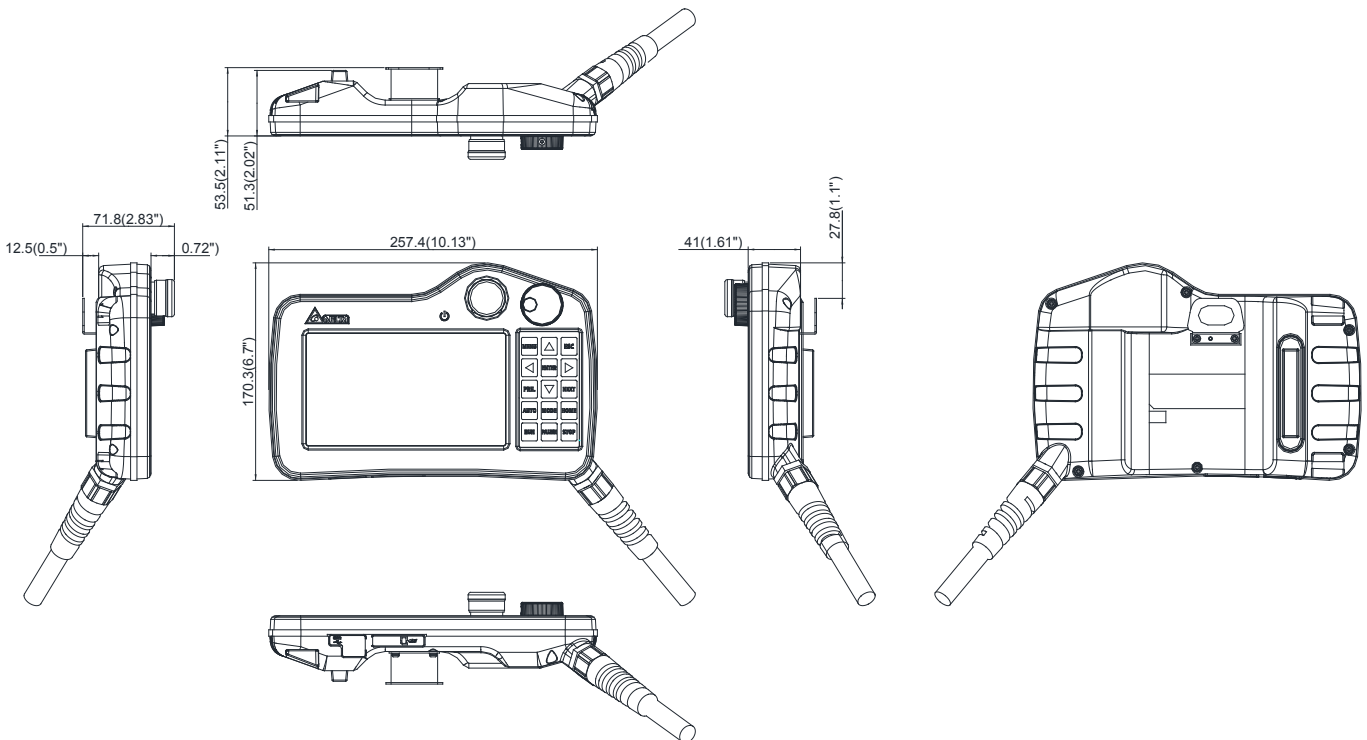



Smarter. Greener. Together.

Industrial Automation Headquarters

Taiwan: Delta Electronics, Inc.

Taoyuan Technology Center
No.18, Xinglong Rd., Taoyuan District,
Taoyuan City 33068, Taiwan
TEL: +886-3-362-6301 / FAX: +886-3-371-6301

Asia

China: Delta Electronics (Shanghai) Co., Ltd.

No.182 Minyu Rd., Pudong Shanghai, P.R.C.
Post code : 201209
TEL: +86-21-6872-3988 / FAX: +86-21-6872-3996
Customer Service: 400-820-9595

Japan: Delta Electronics (Japan), Inc.

Industrial Automation Sales Department
2-1-14 Shibadaimon, Minato-ku
Tokyo, Japan 105-0012
TEL: +81-3-5733-1155 / FAX: +81-3-5733-1255

Korea: Delta Electronics (Korea), Inc.

1511, 219, Gasan Digital 1-Ro., Geumcheon-gu,
Seoul, 08501 South Korea
TEL: +82-2-515-5305 / FAX: +82-2-515-5302

Singapore: Delta Energy Systems (Singapore) Pte Ltd.

4 Kaki Bukit Avenue 1, #05-04, Singapore 417939
TEL: +65-6747-5155 / FAX: +65-6744-9228

India: Delta Electronics (India) Pvt. Ltd.

Plot No.43, Sector 35, HSIIDC Gurgaon,
PIN 122001, Haryana, India
TEL: +91-124-4874900 / FAX: +91-124-4874945

Thailand: Delta Electronics (Thailand) PCL.

909 Soi 9, Moo 4, Bangpoo Industrial Estate (E.P.Z),
Pattana 1 Rd., T.Phraksa, A.Muang,
Samutprakarn 10280, Thailand
TEL: +66-2709-2800 / FAX: +66-2709-2827

Australia: Delta Electronics (Australia) Pty Ltd.

Unit 2, Building A, 18-24 Ricketts Road,
Mount Waverley, Victoria 3149 Australia
Mail: IA.au@deltaww.com
TEL: +61-1300-335-823 / +61-3-9543-3720

Americas

USA: Delta Electronics (Americas) Ltd.

5101 Davis Drive, Research Triangle Park, NC 27709, U.S.A.
TEL: +1-919-767-3813 / FAX: +1-919-767-3969

Brazil: Delta Electronics Brazil Ltd.

Estrada Velha Rio-São Paulo, 5300 Eugênio de
Melo - São José dos Campos CEP: 12247-004 - SP - Brazil
TEL: +55-12-3932-2300 / FAX: +55-12-3932-237

Mexico: Delta Electronics International Mexico S.A. de C.V.

Gustavo Baz No. 309 Edificio E PB 103
Colonia La Loma, CP 54060
Tlalnepantla, Estado de México
TEL: +52-55-3603-9200

EMEA

EMEA Headquarters: Delta Electronics (Netherlands) B.V.

Sales: Sales.IA.EMEA@deltaww.com
Marketing: Marketing.IA.EMEA@deltaww.com
Technical Support: iatechnicalsupport@deltaww.com
Customer Support: Customer-Support@deltaww.com
Service: Service.IA.emea@deltaww.com
TEL: +31(0)40 800 3900

BENELUX: Delta Electronics (Netherlands) B.V.

Automotive Campus 260, 5708 JZ Helmond, The Netherlands
Mail: Sales.IA.Benelux@deltaww.com
TEL: +31(0)40 800 3900

DACH: Delta Electronics (Netherlands) B.V.

Coesterweg 45, D-59494 Soest, Germany
Mail: Sales.IA.DACH@deltaww.com
TEL: +49 2921 987 238

France: Delta Electronics (France) S.A.

ZI du bois Challand 2, 15 rue des Pyrénées,
Lisses, 91090 Evry Cedex, France
Mail: Sales.IA.FR@deltaww.com
TEL: +33(0)1 69 77 82 60

Iberia: Delta Electronics Solutions (Spain) S.L.U

Ctra. De Villaverde a Vallecas, 265 1º Dcha Ed.
Hormigueras – P.I. de Vallecas 28031 Madrid
TEL: +34(0)91 223 74 20
Carrer Llacuna 166, 08018 Barcelona, Spain
Mail: Sales.IA.Iberia@deltaww.com

Italy: Delta Electronics (Italy) S.r.l.

Via Meda 2-22060 Novedrate(CO)
Piazza Grazioli 18 00186 Roma Italy
Mail: Sales.IA.Italy@deltaww.com
TEL: +39 039 8900365

Turkey: Delta Greentech Elektronik San. Ltd. Sti. (Turkey)

Şerifali Mah. Hendem Cad. Kule Sok. No:16-A
34775 Ümraniye – İstanbul
Mail: Sales.IA.Turkey@deltaww.com
TEL: + 90 216 499 9910

MEA: Eltek Dubai (Eltek MEA DMCC)

OFFICE 2504, 25th Floor, Saba Tower 1,
Jumeirah Lakes Towers, Dubai, UAE
Mail: Sales.IA.MEA@deltaww.com
TEL: +971(0)4 2690148