



 REGAL

OWNER'S MANUAL

LX43

December 2025



WELCOME

TO THE REGAL FAMILY

TABLE OF

CONTENTS

5	Our Mission & Values	98	Mercury
7	Limited Warranty	112	Hardtop
15	Introduction	115	Cabin
16	Notes	129	Technical Guide
21	General Vessel Information	131	Propulsion
32	General Boating Safety	137	Electrical
41	Water Sports Safety	157	Garmin Chartplotters
43	Safety Equipment	160	Digital Switching System
44	PFDs	174	Fluids
47	Fire Extinguishers	174	Fresh Water
48	Distress Signals	185	Raw Water
51	Pollution and Waste	191	Safety
54	Rules of the Road	195	Care and Maintenance
62	Physical Walkthrough	201	Final Acknowledgments
64	Stern and Transom	202	Troubleshooting
70	Aft Cockpit	204	Engine Diagnostic
75	Main Cockpit	210	AC/DC Electrical Diagnostic
82	Bow	213	Common Stains/Cleaning
87	Helm	214	Technical Drawings
88	Yamaha	269	Index

OUR MISSION

With God's help, we will develop an exceptional team dedicated to enriching lives and providing an awesome boating experience.

OUR VALUES

Integrity

Gratitude

Relationship-Focused

Excellence-Driven

Ambitious

Team

I know I speak for everyone at Regal when I welcome you to the ever-growing family of Regal boat owners. You've chosen a boat that is recognized worldwide for its standard of excellence. Each step in construction has been carefully scrutinized to assure safety, performance, reliability, and comfort for both your passengers and yourself.

Your yacht is certified by the National Marine Manufacturers Association. It also complies with the applicable standards set by the United States Coast Guard, American Boat and Yacht Council, and the International Marine Certification Institute. Your Regal boat was built with the same attention to detail and quality of construction that we would expect in a craft we would purchase ourselves.

Whether you're a veteran boater or a newcomer, we strongly urge you to read this owner's manual thoroughly. Familiarize yourself with the various components of your vessel, and heed the safety precautions noted herein.

If you have questions that are not covered in this manual, please consult your authorized Regal dealer for assistance, phone the Regal factory at 407-851-4360 or visit www.regalboats.com.

Thank you, and welcome to the "World of Regal"!

A handwritten signature in black ink, appearing to read "Duane Kuck". The signature is fluid and cursive, with a large initial "D" and "K".

President & CEO
Duane Kuck

LIMITED WARRANTY

This document is your Limited Warranty Registration Certificate and Statement of Limited Warranty. Please check the registration information section for accuracy. If this information is not correct or if you change your address at some future date, please notify us at the following address: Regal Marine Industries, Inc., Attention: Warranty Registrations, 2300 Jetport Drive, Orlando, Florida 32809; or email customer.service@regalboats.com.

Please read the Limited Warranty carefully. It contains important information on Regal's claims procedures and your rights and obligations under this Limited Warranty.

WHAT IS COVERED: This Limited Warranty applies to Regal boats beginning with model year 2026.

LIFETIME LIMITED STRUCTURAL DECK & HULL WARRANTY:

Regal Marine Industries, Inc. warrants to the original retail purchaser of this boat, if purchased from an authorized Regal dealer, that the authorized selling Regal dealer or Regal will repair or replace the factory-installed fiberglass if it is found to be structurally defective in material or workmanship, for as long as the original retail purchaser owns the boat. For the purpose of this Limited Warranty, the hull is defined as the single fiberglass casting which rests on the water. The deck is defined as the single fiberglass casting attached to the hull. This Limited Warranty is subject to all limitations and conditions explained below.

FIVE-YEAR TRANSFERABLE LIMITED STRUCTURAL DECK &

HULL WARRANTY: Regal Marine Industries, Inc. warrants to the original retail purchaser of this boat, if purchased from an authorized Regal dealer, in addition to the Lifetime Limited Structural Hull Warranty, Regal offers a Transferable Five-Year Limited Structural Deck & Hull Warranty. Under the

Five-Year Transferable Limited Structural Hull Warranty, the authorized Regal selling dealer or Regal will repair or replace the fiberglass hull or deck if it is found to be structurally defective in material or workmanship within the first five (5) years after the date of delivery to the original retail purchaser. Any remaining term of this Five-Year Limited Hull Warranty may be transferred to a second owner if, within 60 days of purchase, the new owner registers the transfer with Regal and pays the established Limited Warranty transfer fee. Contact Regal Customer Service at the above address for details.

FIVE-YEAR LIMITED HULL BLISTER WARRANTY: Regal Marine Industries, Inc. warrants to the original retail purchaser of this boat, if purchased from an authorized Regal dealer that the authorized selling dealer or Regal will repair any underwater gelcoated surfaces of the hull against laminate blisters which occur as a result of defects in material or workmanship within five (5) years of the date of delivery provided that the original factory gelcoat surface has not been altered. Alteration would include but is not limited to damage repair; excessive sanding, scraping, sandblasting, or improper surface preparation for application of a marine barrier coating or bottom paint, any of which shall void this Five-Year Limited Hull Blister Warranty. Proper preparation must be applied to the hull bottom if the boat is to be moored in the water for periods in excess of sixty (60) days. Regal Marine shall repair or cause to be repaired any covered laminate blisters based on the following prorated schedule.

Less than three (3) years from delivery date - 100%, Three (3) to four (4) years from delivery date - 50%, Four (4) to five (5) years from delivery date - 25%

Reimbursement shall be limited to one repair, not to exceed one hundred and fifty (\$150.00) dollars per foot of boat length prior to prorating. Regal's prior authorization for the method and cost of repair must be obtained before repairs are commenced. All costs to transport the boat for repairs are the responsibility of the owner.

THREE-YEAR BOW-TO-STERN WARRANTY

Regal Marine Industries, Inc. warrants to the original retail purchaser of this

boat, if purchased from an authorized Regal dealer, that the authorized Regal selling dealer or Regal will repair or replace any parts found to be defective in materials or workmanship for a period of three (3) years from the date of delivery. This warranty includes cabinetry, fiberglass parts (aside from hull/deck), upholstery, and other factory-installed components, excluding the items outlined in "What is Not Covered."

ONE-YEAR LIMITED COSMETIC WARRANTY

Regal Marine Industries, Inc. warrants to the original retail purchaser of this boat, if purchased from an authorized Regal dealer, that the authorized Regal selling dealer or Regal will repair cosmetic defects in gelcoat, powder coating, paint, and similar finishes for one (1) year from the date of delivery to the original retail purchaser. This warranty covers cosmetic defects, such as cracks, air voids, or crazing, subject to the limitations and conditions described herein.

CUSTOMER OBLIGATIONS: The following are conditions precedent to the availability of any benefits under Regal's limited warranties:

- (a) The purchaser, who is not Regal's sales agent and is otherwise not in any general or sales agency relationship with Regal, must sign and the authorized Regal selling dealer, must submit to Regal the "**Customer Delivery Acceptance Form**" within fifteen (15) days of the date of delivery and such information must be on file at Regal.
- (b) The purchaser must first notify the authorized Regal selling dealer from whom the boat was purchased of any claim under this Limited Warranty within the applicable Limited Warranty period and within a reasonable period of time (not to exceed thirty (30) days after the defect is or should have been discovered).
- (c) Regal will not be responsible to repair any condition or replace any part, (1) if the use of the boat is continued after the defect is or should have been discovered; and (2) if such continued use causes other or additional damage to the boat or component parts of the boat.
- (d) Based on the authorized Regal selling dealer's knowledge of Regal's Limited Warranty policy and/or consultations with Regal, the dealer will accept the claim and arrange for appropriate repairs to be performed, or deny the claim if it is not within the Limited Warranty policy or is otherwise

excluded.

(e) The authorized Regal selling dealer will contact the Regal boat owner regarding instructions for delivery of the boat or part for covered warranty repair if it is covered by the Limited Warranty. **ALL COSTS TO OR FROM THE BOAT AND/OR TRANSPORT OF THE BOAT FOR REPAIRS ARE THE RESPONSIBILITY OF THE OWNER.**

(f) If the Regal boat owner believes a claim has been denied in error or the authorized Regal selling dealer has performed the covered warranty work in an unsatisfactory manner, the owner must notify Regal's Customer Service Department in writing at the address listed for further consideration. Regal will then review the claim and take appropriate follow-up action.

(g) Before bringing any action, claim, lawsuit or otherwise seeking relief against Regal based on any alleged breach of any of the Limited Warranties' terms or conditions herein, the Regal Boat owner must contact Regal's Customer Service Department Directly and allow Regal, beyond those efforts made by its authorized Regal selling dealer or other authorized Regal dealer, notice and an opportunity to cure any alleged breach of any of the terms of any of the Regal Limited Warranties.

WARRANTY EXCEPTIONS: THIS LIMITED WARRANTY does not cover, the following are not warranted, are excluded from the terms of the Regal Limited Warranty, and the following terms apply to any Regal Limited Warranty:

- (a) Engines, drives, controls, propellers, batteries, generators, gyro stabilization systems, metal plating or finishes, windshield breakage, leakage, fading, and deterioration of paints, canvas, vinyl, upholstery, and fabrics;
- (b) Gelcoat surfaces, including, but not limited to, discoloration or blistering, except as noted above;
- (c) Accessories and items which were not part of the boat when shipped from the Regal factory or which carry their own individual warranty, and /or any damage caused by such accessories and items;
- (d) Damage caused by one or more of the following: misuse, accident, corrosion, galvanic corrosion, negligence, lack of proper maintenance, or improper trailering;
- (e) Any boat used for racing, or used for rental or commercial purposes;

- (f) Any boat operated contrary to any instructions furnished by Regal, including instructions and guidance provided in the Regal Owner's Manual, or operated in violation of any federal, state, Coast Guard, or other governmental agency laws, rules, or regulations;
- (g) The limited warranty is void if alterations have been made to the boat;
- (h) Transportation of boat or parts to and/or from a REGAL factory or service location;
- (i) Travel time or haul outs, loss of time or inconvenience;
- (j) Any published or announced catalog performance characteristics of speed, fuel and oil consumption, and static or dynamic transportation in the water;
- (k) Any boat that has been repowered beyond Regal's power recommendations;
- (l) Boats damaged by accident and boats damaged while being loaded onto, transported upon, or unloaded from trailers, cradles, or other devices used to place boats in water, remove boats from water, or store or transport boats on or over land;
- (m) Any item repaired, replaced, or modified under the terms of this warranty does not in any way prolong, extend, or change any terms set forth in this limited warranty;
- (n) Water damage to, dry rot to, condensation to, or absorption by interior surfaces, wood structures or polyurethane foam; interior wood including, but not limited to, mold, bleeding and/or discoloration as a result of condensation or moisture or water continually contacting the plywood causing staining to upholstery, carpet or other interior surfaces;
- (o) Costs or charges derived from inconvenience or loss of use, commercial or monetary loss due to time loss, and any other special, incidental, or consequential damage of any kind or nature whatsoever.
- (p) Regal reserves the right to improve the design or manufacturing process of Regal boats without obligation to modify previously produced products.

NO WAIVER OF THESE TERMS: The terms, conditions, limitations, and disclaimers contained herein cannot be waived except by the Customer Service Manager of Regal. Any such waiver shall be in writing. Neither the authorized Regal dealer, nor the customer, nor any service, sales, and/or warranty representative of Regal, is authorized to waive and/or modify these

conditions, limitations, and/or disclaimers.

EXCEPT AS SET FORTH HEREIN OR ON ANY OTHER WRITTEN EXPRESS LIMITED WARRANTIES BY REGAL, THERE ARE NO OTHER WARRANTIES EITHER EXPRESS OR IMPLIED PROVIDED BY REGAL ON THIS BOAT. ALL OTHER WARRANTIES, EXPRESS OR IMPLIED, INCLUDING IMPLIED WARRANTIES OF FITNESS AND MERCHANTABILITY, ARE EXPRESSLY EXCLUDED.

REGAL FURTHER DISCLAIMS ANY LIABILITY FOR ECONOMIC LOSS ARISING FROM CLAIMS OF PRODUCT FAILURE, NEGLIGENCE, DEFECTIVE DESIGN, MANUFACTURING DEFECT, FAILURE TO WARN AND/OR INSTRUCT, LACK OF SEAWORTHINESS, AND ANY OTHER THEORY OF LIABILITY NOT EXPRESSLY COVERED UNDER THE TERMS OF THIS LIMITED WARRANTY.

AS SET FORTH ABOVE, REGAL MAKES NO IMPLIED WARRANTY OF MERCHANTABILITY AND EXPRESSLY EXCLUDES ANY SUCH WARRANTY. TO THE EXTENT SUCH EXCLUSION IS NOT ALLOWED BY LAW OR AN IMPLIED WARRANTY OF MERCHANTABILITY IS REQUIRED BY LAW: (1) ANY IMPLIED WARRANTY OF MERCHANTABILITY THAT IS, AS A MATTER OF LAW, NOT PERMITTED TO BE EXCLUDED AS SET FORTH ABOVE, IS LIMITED TO ONE YEAR FROM THE DATE OF DELIVERY TO THE FIRST RETAIL OWNER; (2) NEITHER REGAL, NOR ANY SELLING DEALER SHALL HAVE ANY RESPONSIBILITY FOR LOSS OF USE OF THE BOAT, LOSS OF TIME, INCONVENIENCE, COMMERCIAL LOSS, INCIDENTAL OR CONSEQUENTIAL DAMAGES.

SOME STATES MAY NOT ALLOW EXCLUSIONS OF IMPLIED WARRANTIES OR LIMITATIONS ON HOW LONG ANY IMPLIED WARRANTY LASTS, SO THE ABOVE LIMITATION MAY NOT BE APPLICABLE. SOME STATES MAY NOT ALLOW THE EXCLUSION OR LIMITATION OF INCIDENTAL OR CONSEQUENTIAL DAMAGES, SO THE ABOVE LIMITATIONS OR EXCLUSIONS MAY NOT BE APPLICABLE IN THOSE STATES. THIS WARRANTY GIVES THE OWNER SPECIFIC LEGAL RIGHTS, AND THE OWNER MAY ALSO HAVE OTHER RIGHTS WHICH VARY FROM STATE TO STATE.

THE TERMS AND CONDITIONS CONTAINED HEREIN, AS WELL AS THOSE OF ANY DOCUMENTS PREPARED IN CONJUNCTION WITH THE SALE OF THIS VESSEL MAY NOT BE MODIFIED, ALTERED OR WAIVED BY ANY ACTION, INACTION, OR REPRESENTATIONS, WHETHER ORAL OR IN WRITING, EXCEPT UPON THE EXPRESSED, WRITTEN AUTHORITY OF A MANAGEMENT LEVEL EMPLOYEE OF REGAL.

Some states do not allow limitations on how long an implied warranty lasts, so the above limitation may not apply to you. Regal's obligation with respect to this warranty is limited to making repairs to or replacing the defective parts and no claim for breach of warranty shall be cause for cancellation or rescission of the contract or sale for any boat manufacturer by REGAL MARINE INDUSTRIES, INC.

Regal will discharge its obligations under this warranty as rapidly as possible, but cannot guarantee any specific completion date due to the different nature of claims which may be made and services which may be required. Regal reserves the right to change or improve the design of its boats without obligation to modify any boat previously manufactured. This limited warranty gives you specific legal rights, and you may also have other rights which may vary from state to state. Regal shall in no way be responsible for any repairs not PRE-AUTHORIZED by a Regal Customer Service Manager or repairs performed by a repair shop not PRE-AUTHORIZED by a Regal Customer Service Manager.

ARBITRATION OF DISPUTES AND WAIVER OF JURY TRIAL

EXCEPT AS SPECIFICALLY EXCLUDED IN THIS LIMITED WARRANTY, PURCHASER, REGAL, AND AUTHORIZED REGAL DEALER AGREE TO SUBMIT ANY AND ALL CONTROVERSIES, CLAIMS, OR DISPUTES ARISING OUT OF OR RELATING TO THE BOAT AND THIS LIMITED WARRANTY AND ALL OTHER AGREEMENTS EXECUTED BY PURCHASER RELATED TO THE BOAT TO BINDING ARBITRATION. IT IS THE EXPRESS INTENT OF PURCHASER, REGAL, AND DEALER THAT THIS ARBITRATION PROVISION APPLIES TO ALL DISPUTES, INCLUDING CONTRACT DISPUTES, TORT CLAIMS, FRAUD CLAIMS, AND FRAUD-IN-THE-INDUCEMENT CLAIMS, STATUTORY CLAIMS, AND REGULATORY CLAIMS RELATING IN ANY MANNER TO THE BOAT AND THIS LIMITED WARRANTY.

IF ANY CONTROVERSY OR CLAIM DESCRIBED IN THIS ARBITRATION PROVISION IS DETERMINED FOR ANY REASON TO BE INELIGIBLE FOR ARBITRATION, AND FOR ANY CONTROVERSIES, CLAIMS, OR DISPUTES SPECIFICALLY EXEMPTED FROM ARBITRATION, THEN THOSE CONTROVERSIES, CLAIMS, OR DISPUTES SHALL INSTEAD BE DECIDED BY A JUDGE OF A COURT OF COMPETENT JURISDICTION, IN ORANGE COUNTY, FLORIDA, WITHOUT A JURY. PURCHASER, REGAL, AND DEALER KNOWINGLY AND VOLUNTARILY WAIVE THE RIGHT TO A TRIAL BY JURY FOR ALL SUCH CONTROVERSIES, CLAIMS, AND DISPUTES. PURCHASER, REGAL, AND DEALER UNDERSTAND THAT THERE SHALL BE NO JURY TRIAL, WHETHER THE CONTROVERSY OR CLAIM IS DECIDED BY ARBITRATION OR BY TRIAL BEFORE A JUDGE.

NOTWITHSTANDING THE PROVISIONS OF THIS ARBITRATION AGREEMENT, WITH REGARD TO CONTROVERSIES AND/OR ENTITLEMENT TO POSSESSION OF EITHER THE BOAT OR ANY TRADE-IN, ANY PARTY HERETO MAY RESORT TO A JUDICIAL DETERMINATION (BY A JUDGE AND NOT A JURY) OF SUCH CONTROVERSIES, DISPUTES OR CLAIMS WITHOUT WAIVING ANY RIGHT TO DEMAND ARBITRATION WITH RESPECT TO ALL OTHER CONTROVERSIES, DISPUTES, OR CLAIMS BETWEEN THE PARTIES AS MORE SPECIFICALLY SET FORTH IN THIS ARBITRATION PROVISION.

ALL ARBITRATIONS SHALL PROCEED THROUGH THE AMERICAN ARBITRATION ASSOCIATION AND BE SUBJECT TO ITS COMMERCIAL ARBITRATION RULES, EXCEPT AS SET FORTH HEREIN. THE ARBITRATORS SHALL HAVE THE AUTHORITY TO AWARD ANY FORM OF RELIEF THAT COULD BE PROPERLY AWARDED IN A CIVIL ACTION IN THE STATE OF FLORIDA FOR THE TYPE OF CLAIMS PRESENTED, SUBJECT, HOWEVER, TO ALL LIMITATIONS, PREDICATES, AND CONDITIONS COVERING SUCH REMEDIES OR RELIEF UNDER FLORIDA LAW.

THE PURCHASER, REGAL, OR DEALER MAY DEMAND ARBITRATION OF A CLAIM BY FILING A WRITTEN DEMAND FOR ARBITRATION, ALONG WITH A STATEMENT OF THE MATTER IN CONTROVERSY WITH THE AMERICAN ARBITRATION ASSOCIATION, AND SIMULTANEOUSLY SERVING A COPY UPON THE OTHER PARTY. PURCHASER, REGAL, AND DEALER AGREE THAT THE ARBITRATION PROCEEDING SHALL BE CONDUCTED IN ORANGE COUNTY, FLORIDA, UNLESS OTHERWISE AGREED BY THE PARTIES. EACH PARTY AGREES TO BEAR THEIR OWN ATTORNEY FEES AND COSTS DURING THE PROCEEDING. THE FILING FEES AND ALL OTHER THIRD-PARTY COSTS FOR THE ARBITRATION, INCLUDING THE ARBITRATOR'S FEE, SHALL BE PAID BY THE FILING PARTY INITIATING THE ARBITRATION. THE ARBITRATOR SHALL AWARD TO THE PREVAILING PARTY, IF ANY, AS DETERMINED BY THE ARBITRATOR, REASONABLE ATTORNEY FEES AND REASONABLE COSTS FROM THE NON-PREVAILING PARTY.

INTRODUCTION

Congratulations on purchasing your new Regal boat. Regal is an industry leader in quality and luxury—the LX43 was born out of our commitment to those ideals. Your vessel is certified by the National Marine Manufacturers Association and meets or exceeds standards set by the United States Coast Guard, American Boat and Yacht Council, and the International Marine Certification Institute. We believe you have made the best choice in a crowded field.

As a Regal boat owner, it is important to learn about general boating practices and safety before operating your vessel. This document will first cover rules of the road, safety precautions, and various governmental regulations governing boating. The information contained herein can help reduce the risk of accidents and injury on the water. This manual also contains a physical walkthrough and technical guide regarding your systems and equipment. Regal urges you to read and understand this manual thoroughly before setting out to help keep you and your loved ones safe.

Your Regal owner's manual contains information that will help you operate your craft safely and with ease. There is a QR code placed close to the helm. Scan the code with your smartphone to access your owner's manual. Your owner's manual is not a complete technical manual, but may help troubleshoot select Regal systems and components.

For more information on safe boating practices, visit the US Coast Guard website or usboat.com. Regal recommends taking the usboat.com licensing test for your state to become a licensed boater. Regal does not accept any liability or responsibility for accidents resulting from owner operations.

Your Regal dealer will answer any questions and provide valuable hands-on information during the new boat delivery process. Your dealer has received factory training; employ their services to solve advanced technical problems and perform periodic maintenance. Your Regal dealer also carries a line of factory approved parts and accessories. Call 407-851-4360 or go to regalboats.com to find your closest Regal dealership.



NOTES

NOTES

CALIFORNIA PROPOSITION 65

Boats manufactured for use in California for model year 2018 and after meet the California EVAP Emissions regulation for spark-ignition marine watercraft. Boats meeting this requirement will have a label affixed near the helm.

WARNING

Operating, servicing and maintaining a recreational marine vessel can expose you to chemicals including engine exhaust, carbon monoxide, phthalates, and lead, which are known to the State of California to cause cancer and birth defects or other reproductive harm. To minimize exposure, avoid breathing exhaust, service your vessel in a well ventilated area and wear gloves or wash your hands frequently when servicing this vessel. For more information go to: www.P65warnings.ca.gov/marine.

The fuel system in this boat complies with U.S. EPA mandated evaporative emission standards at time of manufacture using certified components.

Typical Helm CARB Label-
Trailerable Models

EMISSIONS CONTROL SYSTEM
INFORMATION
MEETS U.S. EPA EVAP STANDARDS USING
CERTIFIED COMPONENTS AND MEETS
2020 MY CALIFORNIA EVAP EMISSIONS
REGULATIONS FOR SPARK-IGNITION
MARINE WATERCRAFT

MANUFACTURER: REGAL MARINE
INDUSTRIES, INC.

CALIFORNIA EVAP FAMILY: RRMIPVSSL001
EMISSION CONTROL SYSTEM: CM

MANUFACTURER'S WARRANTY COVERAGE

This evaporative emission control system is warranted for two years. If any evaporative emission-related part on your spark-ignition marine watercraft is defective, the part will be repaired by Regal Marine Industries, Inc.

OWNER'S MANUAL RESPONSIBILITIES

- As the spark-ignition marine watercraft owner, you are responsible for the performance of the required maintenance listed in your owner's manual. Regal Marine Industries, Inc. recommends that you retain all receipts covering maintenance on your spark-ignition marine watercraft, but Regal Marine Industries, Inc. cannot deny warranty solely on the lack of receipts.
- As the owner, you should be aware that Regal Marine Industries, Inc. may deny you warranty coverage of your spark-ignition marine watercraft or a part has failed due to abuse, neglect, or improper maintenance or unapproved modifications.
- You are responsible for presenting your spark-ignition marine watercraft to a Regal Marine industries, Inc. distribution center or a service center as soon as the problem exists. The warranty repairs should be completed in a reasonable amount of time, not to exceed 30 days. If you have any questions regarding your warranty coverage, you should contact Regal Marine Industries, Inc. at 407-851-4360.

SAFETY LABELS

Safety precaution labels are caution, warning and danger signal words. They are highlighted in this manual by font design and symbol usage. A notice heading is included which provides operation and maintenance information but is not hazard-related. An information label provides tips on a variety of topics. Become familiar and understand all safety precaution labels!

PRECAUTIONARY LABELS

Read and understand all safety labels affixed to your Regal boat or found in this manual and the vendor literature. Many of the safety labels are posted close to the helm, aft cockpit, cabin and swim platform. The location of the labels may vary. Review the helm safety labels with passengers before disembarking. Use common sense to analyze the result of an action on board your vessel. Always think safety first!

NOTICE

DO NOT REMOVE OR COVER ANY PRECAUTIONARY LABELS. KEEP HARSH CHEMICALS AWAY FROM LABELS. IF A LABEL BECOMES ILLEGIBLE, CONTACT YOUR REGAL DEALER FOR ORDERING REPLACEMENTS.

NOTICE

GENERAL OR SPECIFIC INFORMATION WHICH IS IMPORTANT FOR CORRECT OPERATION OR MAINTENANCE, BUT IS NOT HAZARD RELATED.

⚠ CAUTION

INDICATES A POTENTIALLY HAZARDOUS SITUATION OR UNSAFE PRACTICE THAT, IF NOT AVOIDED, MAY RESULT IN INJURY, PROPERTY OR PRODUCT DAMAGE.

⚠ WARNING

POTENTIALLY HAZARDOUS SITUATION THAT, IF NOT AVOIDED, COULD RESULT IN DEATH OR SERIOUS INJURY

⚠ DANGER

IMMEDIATE HAZARDOUS SITUATION THAT IF NOT AVOIDED, WILL RESULT IN DEATH OR SERIOUS INJURY.

⚠ CAUTION

READ AND UNDERSTAND THE SEATING ARRANGEMENT DRAWING IN THE TECHNICAL CHAPTER. THIS DRAWING DISPLAYS THE DESIGNATED SEATING ARRANGEMENT FOR A BALANCED LOAD AND VESSEL MAXIMUM PERSONS SEATING CAPACITY.





GENERAL VESSEL INFORMATION

Parts of a Boat

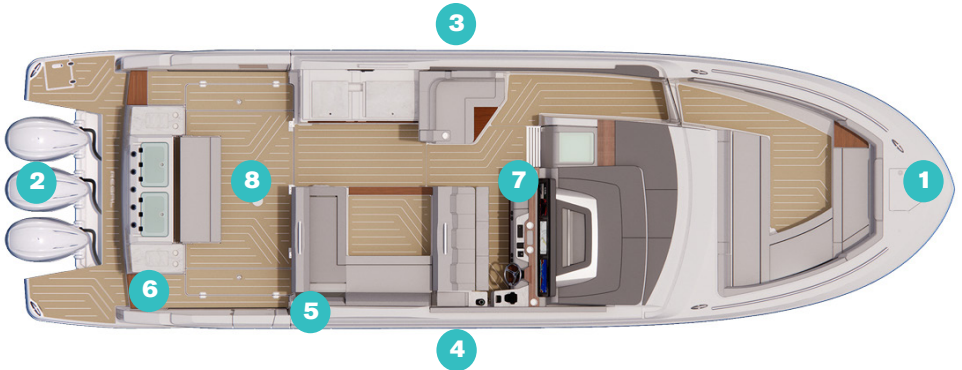

1 - Bow: The front of the boat.

2 - Stern: The rear of the boat.

3 - Port: Left (facing the bow).

4 - Starboard: Right (facing the bow).

5 - Gunwale: The upper edge of the boat.

6 - Transom: The flat edge of the back of the boat.

7 - Helm: The boat's steering equipment.

8 - Lazarette Hatch: The storage area for the engines and other equipment.

Resources and Information

Owner's Information Packet



At time of delivery, your Regal dealer will provide an owner's information packet in a black satchel bearing the Regal logo. Become familiar with the materials contained in the packet including a copy of your extended warranty and valuable information on your propulsion package, systems, equipment, and care and maintenance.

⚠ WARNING

PREVENT INJURY, DEATH, OR PROPERTY DAMAGE! READ AND UNDERSTAND THE REGAL OWNER'S MANUAL BEFORE ATTEMPTING TO OPERATE THE VESSEL.

Hull Identification Number

The "hull identification number" (HIN) is a fourteen character serial number used to identify your boat. It denotes your manufacturer, model, manufacturer serial number, and month and year of manufacture. The HIN is mounted on the starboard side of your boat's transom just below the rub rail on the transom's vertical surface. Locate and write down the HIN for future reference. It can be useful when ordering parts from your Regal dealer.

Typical HIN Plate



Max Capacity Plate

NMMA Yacht Plate

Note: Layouts may vary.



The Maximum Capacity Plate displays the maximum weight capacity and the maximum number of people the boat can carry safely in good weather and is mounted on boats less than 26 ft. (approx. 8m.) long.

Maximum weight is the combined weight of all passengers, gear, and engines.

Never exceed the maximum weight capacity of your boat. An overloaded boat, or a boat with uneven weight distribution, is difficult to steer and can cause accidents.

The NMMA Yacht Plate indicates that your vessel meets or exceeds the U.S. Coast Guard (USCG) safety standards in effect at the time of certification. It is mounted near the helm on Regal boats 26 ft. (approx. 8m.) and over.

Vessel Information Sheet

Fill out this page to keep all information about your vessel handy and organized.

Owner: _____

Address: _____

City & State: _____

Home Phone: _____ Business Phone: _____

In Case Of Emergency Notify: _____

Address _____

City & State _____

Phone _____

Insurance Agent's Name: _____

Policy#: _____

USCG Phone: _____ Local Police: _____

Marina Phone: _____ Slip (Dock#): _____

Hull Serial #: RGM _ _ _ _ _

Key #: _____ Engine: _____

Selling Dealer: _____

Address: _____

City & State: _____

Phone: _____ Fax: _____

Servicing Dealer: _____

Address: _____

City & State: _____

Phone: _____ Fax: _____

Vessel Float Plan

Document your float plan on this page before departing. Leave it with someone responsible on land who can notify the USCG or police if you do not return as planned. Notify the individual if plans change.

Owner: _____

Address: _____

City & State: _____

Telephone#: _____

Person Filing Report: _____

Make Of Craft: _____

Color _____ Trim _____ Hp _____

Inboard _____ Stern Drive _____

Hull I.D.# _____

Documented Vessel # _____

Registration# _____

Length _____ Boat Name _____

Leave From _____

Destination: _____

Fuel Capacity _____

Est. Time Of Arrival _____

If Not Back By _____ o'clock Call Authorities

Safety Equipment Aboard:

Life Jackets _____

Flash Light _____

Flares _____

Cell Phone ___# _____

VHF Radio _____

Lap Top _____

Food _____ Water _____

E-mail address _____

First Aid Kit _____

Persons Aboard:

Name	Age	Address	Phone
------	-----	---------	-------

Vessel Cruise Checklist

Use this checklist to prepare for your trip. Fill out a copy each time you embark.

- Check the local weather forecast.
- Inspect the hull bottom and propellers for damage and marine growth like barnacles.
- Check the sacrificial anodes on the propulsion unit, transom, and engine. Replace if 2 of the 3 nodes are missing.
- Check the electrical system and carry extra fuses.
- Check your bilge pump. If your boat has been in the water, run the pump until water stops flowing. If your boat has been out of the water, check that all bilge water has drained and the drain plug is installed.
- Check that all safety equipment is on board and in good working order including, but not limited to, personal flotation devices, hand held fire extinguishers, and visual and sonic distress signals.
- Check fuel level (See “Fueling,” page 36).
- Open the engine compartment and inspect for fuel odors and visible leaks in the fuel, oil, coolant, exhaust, and power steering systems.
- Check the engine for cracked hoses, worn or loose belts, and loose hardware.
- Check all fuel filters for water.
- Check fluid levels of engines, drives, and generators.

Recommended Onboard Equipment

Tools:

Allen Wrenches
Jack Knife
Pliers
Wrench Set
Screwdriver Set
Side Cutters
Ratchet & Socket Set
Hammer
VOA Electrical Tester
Floating Flashlight/Lantern
Duct Tape

Spare Parts:

Coolant
Oil
Fuses

Basic Gear & Supplies:

Tow Line
Mooring Lines
Dock Fenders
Distress Signals
First Aid Kit
Boat Hook
Wax
Vinyl Cleaner
Emergency Food & Water
Life Raft
Bailer or Hand Pump
Rust Stain Remover Extra Hand
Held Fire Extinguishers
Corrosion Block
Personal Flotation Devices
Rags, Diapers
Shop Vacuum (1 Gal. Cap. Wet-Dry)
Bucket
Squeegee
Binoculars

Delivery Process

Orientation and Inspection

Your dealer must properly complete the delivery process to activate your boat's warranty.

Upon arrival, your dealer will complete an operational orientation of your boat including safety and maintenance instructions. The dealer will also inspect the boat with you in detail. The dealer will document each step of the delivery orientation and inspection on the Customer Delivery Acceptance Form.

After completing the form, you will sign the form acknowledging that the dealer explained the boat's systems and warranty provisions and indicating that all information documented therein is accurate.

Double check the form before signing. An incomplete form or one that is improperly completed may void your warranty.

It is your responsibility to make sure the dealer accurately completes all parts of the Customer Delivery Acceptance Form.

Dealer's Responsibility

It is the dealer's responsibility to provide the location of all relevant owner's resources including, but not limited to: vendor warranties, third party equipment manuals, and the Regal owner's manual for your vessel.

After delivery, your dealer will send all delivery documents to Regal World Headquarters and Regal will send you a warranty certificate within six weeks of boat delivery.

Owner's Responsibility

After completing the Customer Delivery Acceptance Form in full, you are entitled to all benefits and services outlined in your Regal warranty. You also have responsibilities to ensure warranty satisfaction.

1. Read and understand warranty materials.
2. Follow all boating and environmental rules and regulations.
3. Comply with all applicable accident reporting standards and warranty terms and conditions.
4. Read all relevant owner's literature, including this owner's manual, and follow all the recommendations therein.
5. Perform proper maintenance and service your boat according to the standards outlined in your owner's literature.





SAFETY

General Boating Safety

Safety is the skipper's number one priority. As the skipper, you are responsible for the safety of your passengers and all other boats sharing the water. Follow all safety information found in this manual and familiarize yourself and your passengers with safe boating practices every time you embark. Use common sense to analyze the results of an action and always put safety first.

Follow these general guidelines when operating your vessel:

1. Never drink and drive.

Do not mix alcohol and boating. Alcohol impairs the boat operator's ability to make wise decisions and react in emergency situations.

2. Obey all 'Rules of the Road' (see page 54). A weather resistant copy of the rules is included in your black Regal owner's satchel.

3. The spoken word "MAYDAY" is the international signal of distress and is for emergency circumstances only. Never use the word unless there is imminent, life threatening danger.

4. Make sure your boat and essential equipment are in good working order by frequently inspecting the hull, engine, and propulsion components.

5. Posted speed limits, swimming areas, no wake zones, and other restrictions will be marked by white buoys with orange stripes on the top and bottom. Follow all posted restrictions (see, "Navigation Aids" page 59).

6. Always have paper charts on board in case of equipment failure. Up to date charts can be purchased from a National Oceanic and Atmospheric Administration authorized dealer. Head to the NOAA website to find a dealer near you.

7. Never allow anyone to sit anywhere on the boat not specifically designed for seating or stand in the bow area while underway.

Boating and Alcohol

Operating a boat while intoxicated is a federal offense. Operators with a blood alcohol content of .08% (.10% in some states) or higher can be subject to a civil penalties of up to \$1000 or criminal fines of up to \$5000 and/or one year imprisonment.

Intoxicated boating causes the most marine accidents each year. Loss of balance, impaired vision, and decreased judgment all contribute to avoidable boating accidents. You are responsible for the safety of your passengers and other boaters at all times.



DANGER

DO NOT DRINK AND DRIVE.

Severe Weather

Before embarking, check weather conditions. Getting caught in severe weather is hazardous. Stay up to date with the latest weather conditions while on the water.

If you are caught in severe weather, do the following:

1. Slow down and proceed with caution.
2. Put on PFDs (see “Personal Flotation Devices” on page 44).
3. Turn on running lights.
4. Head to the nearest shore that is safe to approach.
5. Navigate into waves at a 45 degree angle if possible.
6. Have passengers sit low and in the center of the vessel.
7. Make sure the bilge pump stays free of water.
8. Secure loose gear and get emergency equipment ready.
9. If the engine fails, trail a sea anchor from the bow of the boat to keep it headed into the waves.



Fog

Avoid operating your boat in fog. When fog sets in, take bearings and log courses and speeds. Emit a five second blast from your horn or whistle once every minute. Wear personal flotation devices and watch for oncoming vessels.

Shallow Water

Shallow water operation presents a number of hazards including sandbars and changing tidal levels. If the vessel strikes an underwater hazard, check for damage. If the engine vibrates more than normal after striking an underwater obstruction the propeller may be damaged. If you run aground, seek help using onboard distress signals (see, "Distress Signals," page 48).





Fueling

Use extreme caution when fueling. Never allow smoke or flame nearby while you are fueling. Turn off engines, all electrical equipment, radios, stoves, and other appliances, and remove all passengers from the boat before fueling.

After fueling, ventilate the vessel by opening all ports, hatches, and doors and running the blower for at least four minutes. Check the bilges for fuel vapors before turning on the engine. Use the sniff test to make sure there is no odor of gas anywhere on the boat. Always check for fuel leaks and fumes after fueling. Be certain you have enough fuel for your cruising needs. Practice the one third rule: use one third of your fuel to go out, one third to return, and keep one third in reserve

Do not start the engine until all traces of fuel vapors are eliminated.

Exhaust and Carbon Monoxide

Carbon Monoxide (CO) can be hazardous, especially in exhaust from gasoline engines and generators, grills, stoves, and space heaters. Diesel engines and generators produce much less CO, but even low levels of CO exposure can be dangerous. Be aware of and avoid:

1. Blockage in exhaust outlets. Blockage can cause CO to accumulate in the cabin and cockpit even if doors, hatches, and portholes are open.
4. Anchoring next to another boat that has their engine or generator running for an extended period. Boats nearby can cause your vessel to accumulate CO.

2. Sleeping on board while an engine or generator is running. It is easy to succumb to CO poisoning while asleep.

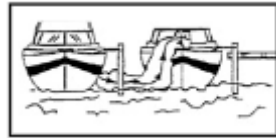

3. Running an engine or generator next to or in a confined area. Sea walls and other confined spaces such as docks can cause CO to accumulate.

5. Operating the engine for an extended period with the canvas deployed. Back drafting or the “station wagon effect” can cause CO to accumulate in the cabin, cockpit and bridge.

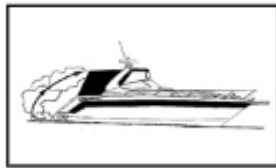
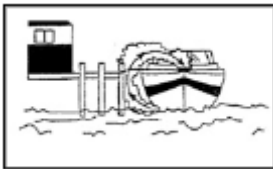

Also:

- Avoid operating your vessel with the bow up while cruising slowly.
- Operating close behind another vessel at slow speeds.



Follow these guidelines to help prevent CO accumulation:

- Make sure all exhaust clamps are in place.
- Look for rust, black streaking, water leaks or damaged fittings. These indicate an exhaust leak.
- Inspect all rubber exhaust hoses for burned or cracked areas. All rubber hoses should feel soft and be free of kinks.
- Make sure that cooling water flows from the exhaust outlet when the engines and generator are started.
- Do not obstruct or modify the ventilation system.
- Do not disable the CO alarms that come installed on your Regal boats and have them serviced periodically.
- When underway, open all hatches, windshield vents, and doors to allow proper airflow from bow to stern. Keep forward facing hatches open at all times, even in inclement weather.
- Listen for changes in exhaust sound. These may be evidence of an exhaust component malfunction.

Symptoms of CO Poisoning

- dizziness
- drowsiness
- nausea
- headache
- ringing in ears
- throbbing temples
- watering/itchy eyes
- flushed appearance
- inattentiveness
- incoherence
- fatigue
- vomiting
- convulsions

Anyone with symptoms of CO poisoning should be placed in a fresh air environment and given medical attention as quickly as possible.

WARNING

INSPECT THE EXHAUST SYSTEM. IMMEDIATELY REPAIR OR REPLACE LEAKING, CRACKED AND CORRODED, OR MISSING EXHAUST COMPONENTS.

NOTICE

CARBON MONOXIDE PRECAUTIONARY LABELS ARE LOCATED AT THE HELM, TRANSOM AND CUDDY CABIN. ENSURE THAT ALL ABOARD READ AND UNDERSTAND THE SIGNS AND EFFECTS OF CARBON MONOXIDE (CO).

DANGER

CARBON MONOXIDE IS A TASTELESS, ODORLESS AND INVISIBLE GAS THAT CAN CAUSE DISCOMFORT, SEVERE ILLNESS, AND EVEN DEATH. EXERCISE CAUTION WHILE OPERATING GENERATOR OR ENGINES IN CONFINED SPACES OR AT DOCK SIDE. DO NOT ALLOW HULL EXHAUST OUTLETS TO BECOME BLOCKED OR EXHAUST FUMES CAN BECOME TRAPPED IN AND AROUND THE CONFINES OF YOUR BOAT. DURING IDLE AND SLOW CRUISE CONDITIONS, BILGE BLOWERS SHOULD BE USED.

Boating Accidents

Take the necessary precautions to avoid accidents and make sure your passengers are educated and prepared to act in an emergency.

Common causes of boating accidents:

- Mixing boating and alcohol.
- Using the deck walk-around to reach the bow at unsafe speeds.
- Sitting on the bow, deck, or swim platform while underway.
- Boating during inclement weather, especially high winds and thunderstorms.
- Disembarking without checking all fluids and systems, especially fuel system components.
- Inattentive boat operation
- Broken emergency equipment
- Improper boat handling
- Inadequate fuel supply and/or navigational aids in open water
- Not wearing PFDs (see below)

Reporting boating accidents

Operators are legally required to report accidents in 48 hours when the accident involves:

- Death
- Injury required treatment beyond first aid
- Passenger disappearance

A formal report must be made within 10 days for accidents involving more than \$2000 worth of damage or complete loss of vessel.



Water Sports Safety

Be particularly careful around those engaging in water sports like scuba divers, water skiers and wake boarders, and fishermen.

Scuba Diving

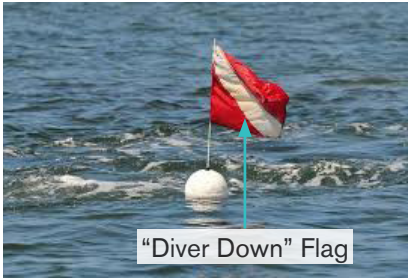

The “diver down” flag indicates there is a diver in water. Use the flag whenever a diver is operating from your boat and continually observe the diver’s air bubbles. Whenever you see a diver down flag, maintain at least 100 ft (approx. 30m) distance in inland water and 300 ft. (approx. 91m) in open water.

Towing Sports

Wear a life jacket when engaging in any towing activities like water skiing, wake boarding, wake surfing, or tubing. The life jacket should remain secure upon impact with the water.

Have a passenger observe the person being towed at all times. This “observer” should not be the operator. Turn your engines off whenever someone is using the swim platform or transom to re-board from the water.

Do not engage in towing sports after dark.



Fishing

When underway, stay clear of fishermen. Nets and lines can get cut or caught in our propeller when operating too close. Slow down when approaching fishing boats and do not return to cruising speeds until clear.

When fishing, never anchor in a shipping channel or tie up to a navigational aid. Lookout for shallow water and hidden obstructions. Use a tidal chart to help avoid grounding.



Swim Platform



Make periodic inspections of all hardware that supports the platform including the ladder. Ensure that all connections and fittings are tight and in good condition. Always retract the ladder and secure in the locked position before making headway.

When operating the boat in reverse, ensure that water does not accumulate on the platform or transom, especially in rough seas. Do not exceed the recommended maximum capacity.

⚠ WARNING

**AVOID SERIOUS INJURY OR DEATH!
DO NOT OPERATE THE BOAT
WITH PEOPLE IN THE WATER
ON TOP OR HOLDING ON TO
THE SWIM PLATFORM STRUCTURE.**



SAFETY EQUIPMENT

Personal Flotation Devices

You are legally required to provide one USCG approved, wearable personal flotation device (PFD) to every person on board. PFDs should be in good condition and readily accessible: able to be worn in a reasonable amount of time in an emergency. Devices should not be stored or locked in closed areas. A PFD that cannot be located quickly in an emergency is useless.

Before embarking, show your passengers where their PFDs are stored and how to put them on. Make sure each PFD is the correct size for the wearer. PFDs should fit snugly, without restricting breathing.

Children under 13 must wear a USCG approved life jacket unless they are below deck or in an enclosed cabin.

Some states have regulations that differ from the USCG regulations. Check your local and state laws before embarking with children. A PFD can save your life, but only if you wear it.

The USCG organizes PFDs into five "Types:" I, II, III, IV, and V. Types I, II, III, and V are wearable PFDs. Type IV PFDs are throw-able and the USCG requires that at least one is available on every vessel in addition to the required wearable PFD.

Anyone being towed behind a vessel, i.e. water skiers and wake boarders, are considered on board the vessel and a PFD is required to comply with the USCG requirements. Water skiers and wake boarders should wear PFDs designed to withstand the impact of hitting the water at high speed.



PFD Types

Type I:

This offshore, inherently buoyant jacket is the most buoyant and is effective in all waters where rescue may be delayed. It will turn most unconscious users to a true, face up position in the water.



Type II:

This near-shore buoyant vest is effective in calm waters where there is a chance for quick rescue. It will turn some unconscious people face up in the water, but not as many as Type I. Some models may need to be inflated.



Type III:

This buoyant flotation aid is effective in inland waters where there is chance for immediate rescue. It is normally used for supervised activities like water skiing, wake boarding, or kayaking. It is designed to help wearers keep themselves in a face up position in the water.



Type IV:

These devices are designed to be thrown to an overboard victim for them to grab onto and hold until rescued. They cannot be worn. Type IV includes ring buoys, buoyant cushions, and horseshoe buoys. At least one Type IV PFD is required on all vessels over 16 ft. (approx. 5 m.).



Type V:

This PFD must be inflated to be buoyant and is only effective in the special cases for which it was designed like sailing vests or deck suits. When inflated, it has similar buoyancy to Types I, II, and III. It must be worn while underway to meet USCG PFD requirements: simply having Type V on board will not count.

Maintaining PFDs

A PFD is only useful if it is well maintained. Every PFD has a life expectancy. Be aware of PFD age and replace it with past life expectancy. Use the following checklist to inspect and maintain your PFDs.

- Check for broken zippers, frayed webbing, water soaked kapok bags, missing straps, and stitching that has become undone.
- Clean PFDs with soap and water, and let them dry completely before storing.
- Check any kapok-bagged jackets by squeezing the bag and listening for air. If you hear air escaping, the bag is defective and should be discarded.
- Grab the cover with your fingers. If the cover material rips, the PFD should be discarded.
- If the kapok bag is hard, the PFD should be discarded.

Life Rafts

Inflatable life rafts are recommended for ocean going vessels. Make sure the raft is large enough for everyone on board and contains proper emergency equipment. Make sure the raft is USCG approved and have the unit serviced periodically



Fire Extinguishers

USCG approved marine type fire extinguishers are required on all recreational boats with a permanently installed fuel tank. Fire extinguishers are classified with a letter and a number. The letter indicates the type of fire the extinguisher is designed to put out; the number indicates the size of the extinguisher. USCG approved extinguishers are all type 5-B and can be identified by a marking on the label. Type B extinguishers are designed to put out fires caused by flammable liquids like grease, oil, and gasoline.

Approved extinguishers have a marine type mounting bracket that keeps them mounted when on the water. Extinguishers should be mounted in a readily accessible location that will not hinder passengers while underway. Always check state and local laws and regulations for any additional requirements.

Refer to the table below for fire extinguisher requirements based on your boat's length.

Length (feet)	Minimum number of 5-B portable fire extinguishers required ¹	
	If no fixed fire extinguishing system in machinery space	If fixed fire extinguishing system in machinery space
Under 16	1	0
16 or more, but less than 26	1	0
26 or more, but less than 40	2	1
40 or more, but not more than 65	3	2

¹ One 20-B portable fire extinguisher may be substituted for two 5-B portable fire extinguishers.

Distress Signals

All vessels operating in the navigable, coastal and territorial waters of the United States must be equipped with USCG approved visual distress signals. Vessels owned in the United States and operating on the high seas must also have approved visual distress signals.

Pyrotechnic Devices

Pyrotechnic visual distress signals must be USCG approved and readily accessible. All devices display the service life. Do not use expired devices.

A minimum of six devices is required: three for day and three for night. Some devices will meet both day and night requirements, some will not. Pyrotechnic devices should be stored in a cool, dry location. Devices should be stored in a high visibility, watertight container.

There are three types of USCG approved devices:

1. Pyrotechnic red flares, hand held or aerial (day/night).



2. Pyrotechnic orange smoke, hand held or floating (day).



3. Launchers for parachute flares or aerial red meteors.



Pistol style launchers handle like firearms and should be treated with the same care and caution. Some devices are banned in certain locales. Check state and local regulations before embarking.

No distress signal is best in all circumstances, but pyrotechnics are widely considered the most effective. They do, however, emit a searing flame that can cause burns and ignite flammable materials. Check the area around you and practice caution when operating.

Non-Pyrotechnic Devices

Non-pyrotechnic visual distress signals must be marked USCG approved and readily accessible.

There are two types of devices:

1. Orange distress flags: For day use only. Must be 3x3 or larger with a black square and ball on an orange background. Should be able to be spotted when displayed from a boat hook or long fishing rod, or when attached to a paddle and waved overhead.

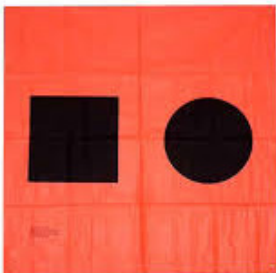

2. Electric distress lights: For night use only. Used to flash the international SOS distress signal in Morse code (...---...). Under inland navigation rules, a white light flashing at regular intervals 50-70 times a minute is commonly considered a distress signal, however, it does not meet the USCG carriage requirements for a visual distress signal.



Do not display any visual distress signals under any circumstances except when assistance is required to prevent immediate danger to passengers.

Sonic Devices

All boats must carry a sound signaling device. Navigation Rules require sound signals be made under certain circumstances like crossing or overtaking (see, “Rules of the Road” page 54). All vessels are under 13 meters long and are required to carry a whistle in inland and international waters.

VHF Radio



Very high frequency or VHF radios are used for distress signaling, ship to ship, and ship to shore communication. All Regal boats leave the manufacturer with a VHF-FM radio installed. Channel 16 is the primary channel for ships in distress.

To make a distress call on your VHF-FM radio:

1. Make sure the radio is on.
2. Turn the radio to channel 16.
3. Press/hold the transmit button.
4. Clearly say, “Mayday, Mayday, Mayday.”
5. Communicate:
 - Vessel name, HIN, and description
 - Position/location
 - Nature of emergency and
 - Number of people on board
6. Release the transmit button.
7. Wait ten seconds for a response.
8. If there is no response, repeat steps



POLLUTION AND WASTE DISCHARGE

Pollution Regulations

Marpol Treaty

The International Convention for the Prevention of Pollution from Ships (MARPOL) prohibits dumping refuse matter of any kind into the waters of the United States including oil, garbage, and other liquid pollutants.

Federal Water Pollution Control Act

The Federal Water Pollution Control Act prohibits discharge of oil or hazardous substances into the navigable waters of the United States. No vessel may intentionally drain oil or oily waste from any source into the bilge of any vessel. Violators are subject to civil penalties and/or criminal sanctions including fines and imprisonment.

The act requires that all vessels equipped with propulsion machinery be capable of storing oily mixtures and oil discharge on board. On recreational vehicles, buckets, heavy plastic bags, or portable pumps are suitable for retention on board.

There is a placard mounted in the engine compartment that contains additional information.

Immediately notify the USCG if your vessel discharges oily or hazardous substances. Call toll free at 800-424-8802. Report location, source size, color, substance and time observed.

The Act to Prevent Pollution from Ships

The Act to Prevent Pollution from Ships limits the discharge of garbage from vessels. It is illegal to:

1. Discharge plastic or garbage with plastic into any waters in the navigable United States and in all other waters within 3 nautical miles of the nearest land.
2. Discharge plastic, dunnage, lining, and packing materials that float within 25 nautical miles from the nearest land.

Violating these laws may incur a civil penalty of up to \$25,000, a fine of up to \$50,000 and imprisonment for up to five years for each violation. Regional, state, and local laws may also apply.

Waste Discharge

Marine Sanitation Devices

Recreational vessels under 65 ft. (approx. 19m) with installed toilet facilities must have a marine sanitation device (MSD). All Regal boats with toilet facilities include a Type III MSD per USCG requirements. Type III devices do not chemically treat wastewater and therefore it is illegal to empty wastewater tanks, on all Regal boats, into any waters in the contiguous United States.

Dumping untreated wastewater is allowed only 3 miles off ocean coasts and 12 miles of the coast in the Gulf of Mexico.

No Discharge Zones

In 'No Discharge Zones' it is **illegal** to dump treated or untreated wastewater. Contact your local and state environmental agencies to find specifics on any zones in your area.

Do your part to help keep our waterways clean.





RULES OF THE ROAD

Introduction

Just like there are rules for driving on the road, there are also rules for driving on water. These ‘Rules of the Road’ define the responsibilities of vessel operators and, when followed correctly, can reduce boating accidents. It is your responsibility to understand and follow them whenever encountering another vessel.

72 COLREGS

The International Regulations for Preventing Collisions at Sea 1972 (72 COLREGS) are published by the International Maritime Organization and set out the “Rules of the Road.” Both inland and international rules follow the 72 COLREGS, but contain some slight differences.

This section is only an introduction included for convenience. It is not exhaustive. We recommend additional education before getting behind the wheel. The complete rules can be found on the USCG website.

Navigation Rules

The Navigation Rules establish actions to be taken by vessels to avoid collision and are divided into international and inland rules. Operators of vessels 39.4 ft. (approx 12m) and over are required to keep a copy of the inland navigation rules onboard at all times.

Vessels that have the right of way are designated “stand-on” vessels. It is their responsibility to maintain course and speed when encountering another vessel. Vessels that do not have the right of way are “give-way” vessels. They are responsible for yielding to the stand-on vessel to avoid collision. In general, larger, less maneuverable vessels have the right of way. This includes:

- Sailboats driven by wind
- Vessels engaged in fishing
- Vessels performing work that limits their mobility
- Vessels run aground or otherwise not under command.

Smaller boats are also obligated to avoid close quarters with larger tonnage vessels.

Encountering Vessels

There are three main situations in which you will encounter another vessel: meeting, crossing, and overtaking. Post a lookout to watch for dangers that may come from any direction and assist in navigation when encountering another vessel.

Meeting

In a head on meeting, neither vessel has the right of way and both must take action to avoid a collision.

Vessels must sound a single blast (see “Sonic Devices”, page 50) if steering toward starboard and passing the other vessel on the port side.

Vessels must sound two blasts if steering toward port and passing the other vessel on the starboard side. Port side passing is preferred.

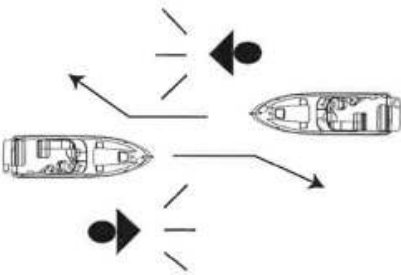

Crossing

When two vessels cross in close proximity, the vessel that views the other from the starboard side is the give-way vessel and must alter course to avoid the stand-on vessel. The stand-on vessel views the other from the port side and should maintain its current speed and trajectory.

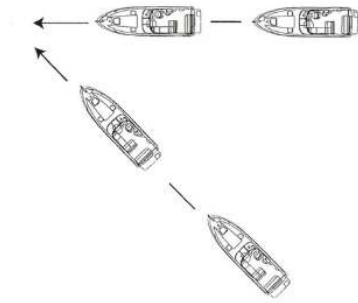

Overtaking

When overtaking another vessel, the vessel overtaking is the give-way vessel. Give one short blast if overtaking to starboard and two short blasts if overtaking to port.

When the stand-on vessel replies with the same, alter your course and speed to pass while staying well away from the stand-on vessel. The stand-on vessel should maintain its speed and course until overtaken. If it is unsafe to pass, the stand-on vessel will respond with five short blasts.

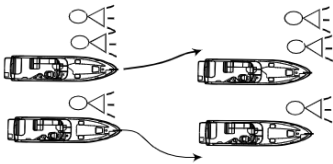

In the event of an imminent collision, no vessel has the right of way. Both vessels must take evasive action to avoid the collision.

! WARNING
FOLLOW THE NAVIGATION "RULES OF THE ROAD" TO PREVENT COLLISIONS AND AVOID INJURY AND DEATH.



Safety and Security Zones

In response to the terrorist attacks of 9/11 and the attack on the USS Cole, the USCG established Safety and Security Zones to keep U.S. Naval vessels, commercial vessels, cruise ships, and essential infrastructure safe.

Help protect our country by following all rules and regulations.

1. You may not approach within 100 yards (approx. 91 m) of any U.S. naval vessel. When this is unavoidable, contact either the vessel or USCG escort vessel on channel 16 of your VHF-FM radio.
2. You must operate at minimum speed when within 500 yards (approx. 457m) of these vessels.
3. You must avoid operating your vessel near all cruise liners and some commercial vessels.
4. You must avoid operating your vessel near all security zones and commercial ports. Most dams and power plants near water also have restrictions.

Rendering Assistance

All operators are obligated by law to provide assistance to other vessels in dangerous situations on the water. Operators may be subject to a fine for failure to do so.



Navigation Aid

Navigation aids, like buoys or beacons, are placed along coastal and navigable waters to help operators determine their position relative to land and as guides to mark safe water and hidden dangers. Each aid provides specific information.

Aids are often used together to form a system that helps operators follow the natural and improved channels. Such systems also help with coastal plotting.

Lateral Aids



Buoys and beacons called lateral markers indicate the port and starboard sides of a given waterway. All U.S. lateral markers follow the traditional 3-R Principle: red, right, returning. When returning from sea and heading inland, keep the red markers on your right or starboard and keep the green buoys on your left or port.

Information and Regulatory Markers

These orange and white markers are used to alert operators to various warnings and regulations.

Characteristics include:

1. Orange bands running horizontal across the top and bottom of a white body
2. Black text in proximity to an orange circle, square, diamond, or diamond with a cross in the center.
3. Buoys or beacons
4. Blinking, white light

Refer to the US Coast Guard website for specific information on navigation aids.

Night Running

Night time operation can be dangerous. Boats operating between sunset and sunrise must use navigation lights. At night, all rules of the road still apply, but it is best to slow down and stay well clear of other vessels regardless of who has the right of way.

Navigation Lights

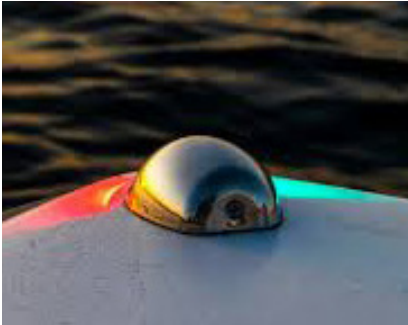

Use running lights to gather information about any vessel you encounter at night.

Green lights indicate the starboard side and red lights the port. If you see green lights, you have the right of way. If you see red lights, you must yield. Size, speed, and position can be difficult to determine in the dark. It is best to avoid encountering other vessels if possible.

The USCG requires recreational boats to display navigation lights between sunset and sunrise and any other periods of reduced visibility.

Navigation lights help avoid collision by improving visibility. All Regal boats are required to have navigation lights displayed on the vessel as indicated. Follow all manufacturer instructions regarding replacement of navigation lights and Do not tamper or otherwise modify navigation lights for any reason.

Bridges

Clearance

Your vessel has a specified bridge clearance height. This height is an estimate of the distance from the waterline to the top of the highest equipment on board. The estimated height can change for a variety of reasons including variances in the vessel's loaded condition and variances in equipment.

Some Regal boats come equipped with fold-able towers that facilitate easy passage under low bridges. Some bridges will be marked with a clearance measurement, but others won't. Know your boat and take appropriate action when approaching a bridge to avoid damaging your vessel.

After making sure your vessel will clear a bridge, proceed with caution at a safe speed. Often, green or white lights will mark the safe or main channel under a bridge. Green may also denote the "up" position on lift bridges. Refer to the chart on the following page for diagrams of common bridge lights.

You may resume a safe, cruising speed once you are clear of the bridge and have clear visibility of the water on all sides. Never park under a bridge and always use common sense when maneuvering near bridge structures.





PHYSICAL WALKTHROUGH

Vessel Sections

The Regal LX43 is equipped with a wide range of features, organized into the following sections. The “Physical Walkthrough” section provides an introduction to the vessel’s key components and is designed to familiarize you with its layout. For detailed technical specifications and in-depth information, refer to the “Technical Guide,” which begins on page 129.

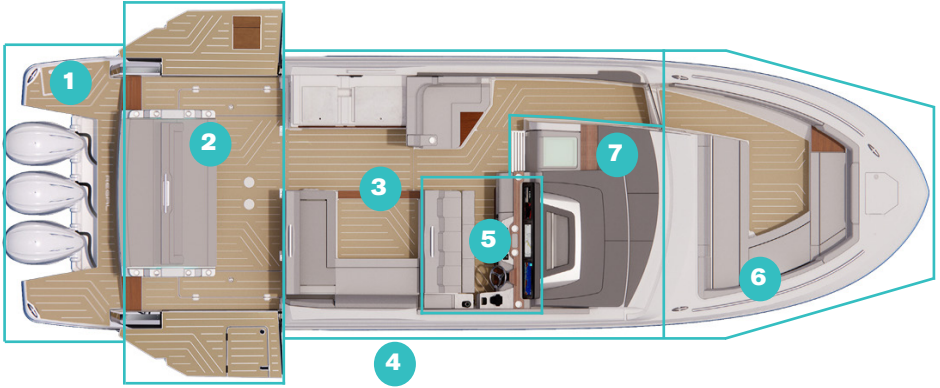

Note: Layouts may vary. Yamaha package pictured.

- 1 - Stern and Transom
- 2 - Aft Cockpit
- 3 - Main Cockpit
- 4 - Hardtop (not pictured, above Main Cockpit)
- 5 - Helm
- 6 - Bow
- 7 - Cabin Entrance

Stern and Transom

The stern and transom areas are pictured below, including locations of various features and amenities present in this section of the vessel. The walking surface in this section (and around the engines) is referred to as the “swim platform.”



Note: Details may vary.

- 1 - Shore Power Reel
- 2 - Transom Washdown (Freshwater)
- 3 - Stern Anchor
- 4 - Shore Water Inlet
- 5 - PowerPlatform (Mercury only)
- 6 - Deployable Ladder

Deployable Ladder

The deployable ladder provides a safe way to enter the boat from the port side of the swim platform. To access the ladder, open the cover, lift and pull the ladder to the port side, extend the rungs, and finish rotating the ladder down into the water. Close the cover to allow a stepping surface when climbing aboard. To stow, collapse the ladder steps and return to the dedicated storage.

Transom Washdown

The stern and transom section also contains a freshwater washdown. It can be accessed in the location shown above. It functions as a retractable hose. Simply pull the hose out and twist to adjust the water temperature. The freshwater system must be activated (see page 161).

⚠ WARNING

AVOID ENGINE PROPELLERS WHEN REBOARDING THE VESSEL. DO NOT GRAB HOLD OF ANY ENGINE PARTS FOR MANEUVERING TO THE LADDER.



Shore Power Reel

Use the retractable shore power reel to connect to a marina's shore power tower. This will power the boat's 120v AC system through the Main Distribution Panel (see page 119). If the ELCI breaker is tripped, the vessel will not receive shore power (see next page). For more information on how shore power functions, see page 146.

Stern Anchor

The stern anchor provides an extra method of anchoring the boat and keep it from drifting. It is accessed from the aft side of both the convertible transom seat and UltraLounge through a hatch. The stern anchor is only operated manually. The anchor rode/rope must be secured to a cleat before tossing into the water.

Shore Water Inlet

Located on the aft face of both the convertible transom seat and the UltraLounge, the shore water inlet allows the freshwater system to pull from an external source instead of the limited freshwater tank. For more information, refer to page 176.

Transom Doors

It is important to secure the transom doors whenever the vessel is underway. First, lift directly upwards from the top edge to disengage the hinge lock. There are 3 configurations: pointing forward, pointing outboard, and pointing aft.



Transom door closed



Transom door open

ELCI

The ELCI breaker can be found in the port-side tub for the convertible transom seat, behind an access panel within the wall of the storage tub. For the UltraLounge, it is behind a cover panel with a pull-strap. See pictures for more detail.



ELCI breaker

For the ELCI itself, shown in the top-right, the breaker switch is on the right-hand side. When in the ON position, test the breaker by pressing the white button. If the switch flips to the OFF position, it is working as intended. If the switch remains ON and no change occurs, please contact your dealer or our Regal Customer Service team.



ELCI - Convertible transom seat



ELCI - UltraLounge

Fender Clips

Fender clips allow a quick and simple method to attach and remove fenders. To attach a fender using the fender clips, first tie the fender line to the fender opening, then insert into the hull until it is locked in place. To remove the fender, press the quick release mechanism and pull the fender clip out.

Do not use fender clips as cleats. Improper use is not covered by your warranty.



Fender clip orientation



PowerPlatform (Mercury)

The PowerPlatform is a component that comes on boats equipped with a Mercury propulsion package.

The PowerPlatform sits under the swim platform on the starboard side and can be raised or lowered to provide seating in the water or make it easier to enter and exit the boat from the stern. There is a physical switch on the starboard side of the convertible transom seat. Press the

bottom button to deploy the platform and press the top button to retract. See page 71 for the button location on the UltraLounge.

To operate the platform from the DSS, navigate to the “Deck” page. Press the down arrow once to deploy and the up arrow once to retract (see “Digital Switching System”, on page 164).



Aft Cockpit

The aft cockpit is the next section fitted with many convenient features. Depending on customizations, you may first see the convertible transom seat with dual pressurized baitwells, or the Regal UltraLounge.

Convertible Transom Seat



The convertible transom seat contains two pressurized wells for live bait, two storage compartments on each side, and a pull-out bench. To activate the baitwells, refer to page 188. To extend the seating, pull outwards from the top face while facing aft. The result is shown below.



Convertible transom seat deployed

UltraLounge



The UltraLounge can be modified in 4 ways: move the backrest forward and aft, rotate the backrest to change the angle, lift the thighrise function, or move the entire structure forward and aft. Buttons controlling each of these movements are shown on the next page.



UltraLounge thighrise

UltraLounge Operation

Actuated

Below the backrest handle, the button with parallel arrows allows the entire backrest to move forward and aft; press the button with the curved arrow to adjust the angle of the backrest. Before moving, ensure the locking pins are disengaged by slightly moving the component back and forth. Apply incremental force to move.



Actuated backrest buttons

Manual

Pull the small steel handle upwards to disengage the locking pins and move the backrest forward or aft. The backrest angle rotates simply by force - there is no locking mechanism. The weight of the backrest will prevent free movement when underway.



Manual backrest handle

Use the buttons on the inner face of the armrests to control the vertical thighrise on either forward or aft sections, respectively.



Thighrise controls

To move the entire UltraLounge forward and aft, press and hold the buttons on the outer face of the armrests, located forward and port-side (shown below). The buttons on the starboard aft face of the armrests control the PowerPlatform.



Forward and aft control



PowerPlatform control

Fishboxes

Fishboxes are located in the deck floor on the port and starboard sides of the aft cockpit seating area. They are insulated and come equipped with a drainage system and macerator-style pump. Each fishbox macerator operates independently. To activate the drainage system, tap the corresponding icon in the “Deck” page of the DSS (page 164). Do not operate without running water, as it may damage the water pumps.

To open a fishbox, lift up the ring tab on the fishbox lid, turn the tab 90° counterclockwise, and open the lid. To lock a fishbox, close the lid, turn the tab clockwise, and return the tab to its flush position.



Port side fishbox

Terrace Doors

Regal's Terrace Doors fold down to create an expanded entertainment area in the aft cockpit. The doors are controlled from the “Deck” page of the DSS. To operate, tap and hold the corresponding arrow. Alternatively, deploy the Terrace Doors using the manual buttons on the hardtop.



Port Terrace Door buttons

A locking pin secures and stabilizes the door when upright. The pin is engaged if the light indicator within the DSS (next to the control arrows) is green as shown below. When the pin is disengaged or the doors are lowered, the light will be yellow.



DSS Terrace Door buttons

The Terrace Doors also include a dive door on the starboard side when in the raised position. Simply press and slide the latch to disengage and unlock the doors.



Starboard dive door



Lastly, on the port side, there are boarding steps that fold into the gunwale (see image to the right). These steps provide a way to board the vessel with ease. Pull downwards on the bottom step handle to deploy.

⚠ CAUTION

AVOID COLLISION BETWEEN THE **ULTRALOUNGE AND DIVE DOOR!** ENSURE THE ULTRALOUNGE IS POSITIONED **AS AFT AS POSSIBLE.**

Lazarette Compartment

The Lazarette Compartment contains many components of the electrical, fluids, and propulsion systems.

The hatch can be opened using nearby buttons, or the Digital Switching System (see page 164). For the convertible transom seat, the buttons for manual operation will be on the starboard side - it can also be opened digitally. For the UltraLounge, the hatch can only be opened digitally. Be sure to move the UltraLounge completely towards aft to avoid collision with the hatch.

To open, simply press the corresponding button once. To close, the button must be held, whether it be done manually or digitally. This is to prevent injury to anyone near the hatch door or damage to any objects in the way of the compartment hatch.

⚠ CAUTION

AVOID COLLISION BETWEEN THE **ULTRALOUNGE AND LAZARETTE HATCH!** ENSURE THE ULTRALOUNGE IS POSITIONED **AS AFT AS POSSIBLE.**

Aft Cockpit Options

The optional base inserts are for the cockpit table and/or rocket launcher. To install either option, follow these steps:

1. Retrieve the base plate and support posts from the Mezzanine storage compartments.
2. Secure the base plate to the deck using the T-bolt, then insert the support posts.
3. Place the table or rocket launcher on the support posts and secure it by turning the lock.

For the table option, make sure to slide out the support plates before unfolding the table.



Base plate with T-bolt



Support posts

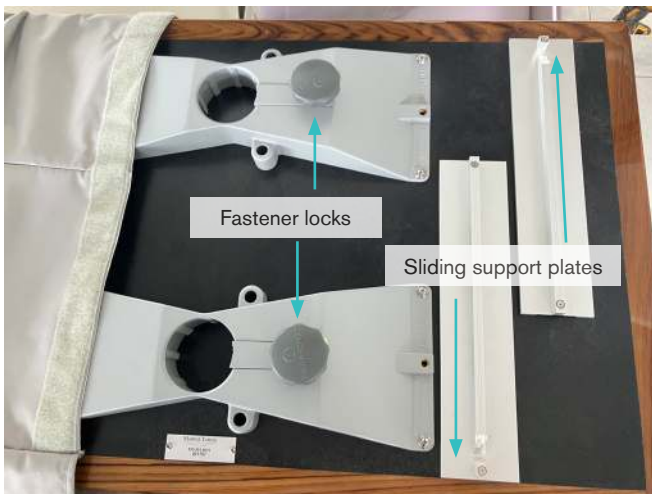

Main Cockpit

The main cockpit is the next section featuring the refreshment island and cockpit seating with multiple storage compartments.



Rear Cockpit Seating

The backrest on the starboard side shown in the photo above can be pivoted forward and aft to allow for different seating configurations. To move the backrest, simply apply force at the center of the stainless steel handle at the top.



Alternate configuration

On the aft face of this seating are two drawers: the top one is for storage and the other serves as a foot-rest.

The foot-rest has a locking mechanism that prevents it from sliding back and forth. To extend the step outwards, flip the tab down on the front face and rotate to a vertical orientation as shown. To stow, there is a lock-release tab on the starboard face - simply pull to disengage the lock and repeat the steps in reverse order. The red circle indicates the correct orientation. Ensure it is facing upwards and is not visible when the tab is flush.



Orientation indicator (red circle)



Vertical orientation



Release tab

⚠ CAUTION

AVOID COLLISION BETWEEN THE LAZARETTE HATCH AND FOOT-REST! ENSURE THE STEP IS STOWED AWAY.

Refreshment Island



Washdowns

Two washdowns are found on the aft face of the refreshment island. The top one is for raw water and the bottom one is for freshwater. Simply pull out and twist to activate. Ensure the respective water systems are active.



Trashcan

A trashcan on aft face of the refreshment island with an opening to allow bottles/cans and other trash to be thrown away without opening it. A U.S. Coast Guard metal plate on the inside wall outlines the rules and regulations regarding waste disposal. Please take time to understand the conditions for waste disposal, as you may be held legally responsible if done incorrectly. Important information on this topic is detailed on page 51.

Freshwater Sink

The sink uses water from the freshwater tank; ensure it has been filled. Before activating the freshwater system, check the strainer next to the freshwater pump (see page 175). Remove any debris. Once clear, activate the system within the “Deck” page of the Digital Switching System (DSS, page 161) by holding the “FRESH WATER” icon for two seconds. Finally, open a faucet to purge air from the system and check that there is water flowing from the tap.

There is a droplet “WATER” icon on the left side of the DSS screen. Keep an eye on freshwater levels before embarking and while on the water to avoid running out of water.



DSS icons

Dual Electric Grills

There are two 120/220v electric grills on the starboard side of the refreshment bar. The grills run on AC power and need no other fuel source to operate. To operate, first use the battery activation panel (page 87). They should be ready to use- if not, ensure the grill breakers are turned on at the MDP (page 119).

The grill lid has a safety shutdown feature that will activate the safety shutdown switch. The grill will deactivate. Always keep a fire extinguisher within reach while using the grill to avoid the fire spreading. Contact your Regal dealer after assessing damages.

In any event other than an emergency, turn the grill off and let it cool completely before closing the lid to avoid damage.



Refrigerators

The refreshment island comes with either two refrigerators or one refrigerator and one freezer. Each refrigerator (as well as the optional freezer) can hold up to 95 liters of food and drink and comes with a separate freezer drawer, bin, bottle racks to secure items while at sea, and a stainless steel door covered with acrylic.

The units run on AC current. Once the battery activation panel is turned on (page 87), the units should automatically begin cooling. Make sure the refrigerator breaker is switched on at the Main Distribution Panel (MDP) if they do not start up automatically (see page 119).

There is a temperature control under the overhang. The power button on the right will turn the refrigerator on. The snowflake button next to the power button will change the temperature setting. There are five temperature settings. Temperature setting and other specific operational instructions can be found in the manufacturer owner's manual included with your welcome packet.

Regal recommends turning the refrigerators on and allowing them to run for six hours prior to stocking to ensure that any perishable items are kept as cold as possible.

Periodically clean the door and interior of the refrigerator with standard household cleaners to prevent mold and other food contaminants from building up. Refer to the manufacturer manual for specific care and maintenance instructions.



Starboard Cockpit Seating

This section of the main cockpit has extra seating, storage, and base for the table options. Similar to the rear seating, the helm seat can also be moved to face aft, allowing a more communal seating arrangement.

The center bench can be flipped up to access a storage area, as well as metal tubs for the grills and a manual fire extinguisher release pin.

The center backrest can also be flipped up to access two Garmin Empirbus module. This is a component of the digital system (see page 170).

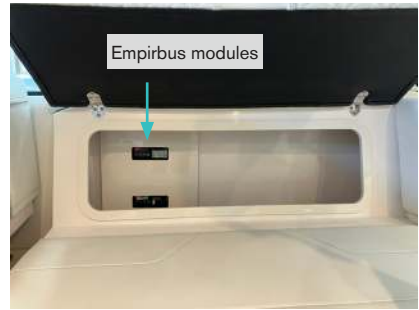

Center seat backrest

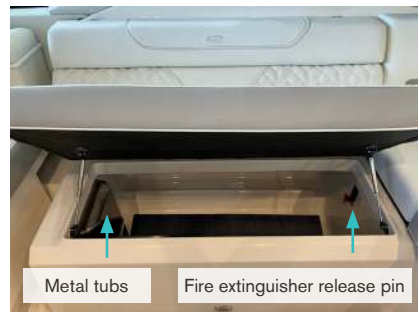

Center seat bench



Companion Seating

Past the refreshment island is an L-shaped seating with another storage drawer, two air conditioning vents, cup holders, and a wireless charger in the gunwale indentation.

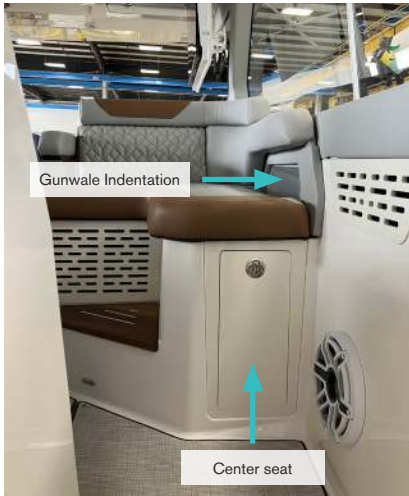

Companion seating

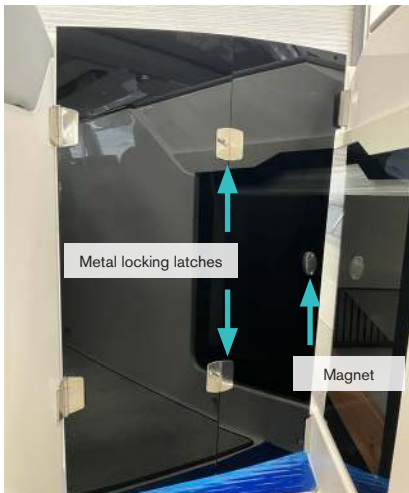

Bow access door (latches unlocked)

Bow Access Passageway

Leading to the bow section are two sets of actuator buttons and a small door.

The first set of buttons controls the port window to slide it forward and aft. The second set of buttons (closer to the bow) slides a section of the windshield out of the way to provide unobstructed access to the bow.



The bow door has a magnetic attachment on the port gunwale that fixes the door's position when open. When closed, it slides into metal slots. Use the two metal latches running down the middle bend of the door to lock it in place. It is unlocked as shown in the photo to the left.

Bow

The front and starboard seats have storage underneath the seat cushions. In the gunwales on either side are cup holders and USB outlets. There are also grab rails on both sides of the seating area for extra stability while underway. The bow step on the port-side allows you to ascend without stepping on and potentially damaging the upholstery.

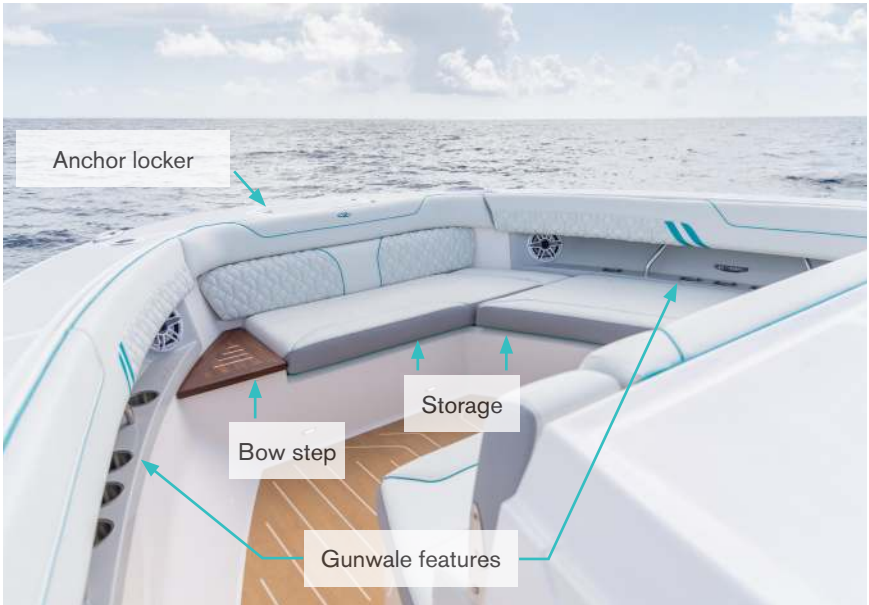

Anchor Locker

The anchor locker carries a couple important components, namely the windlass anchor and freshwater washdown.

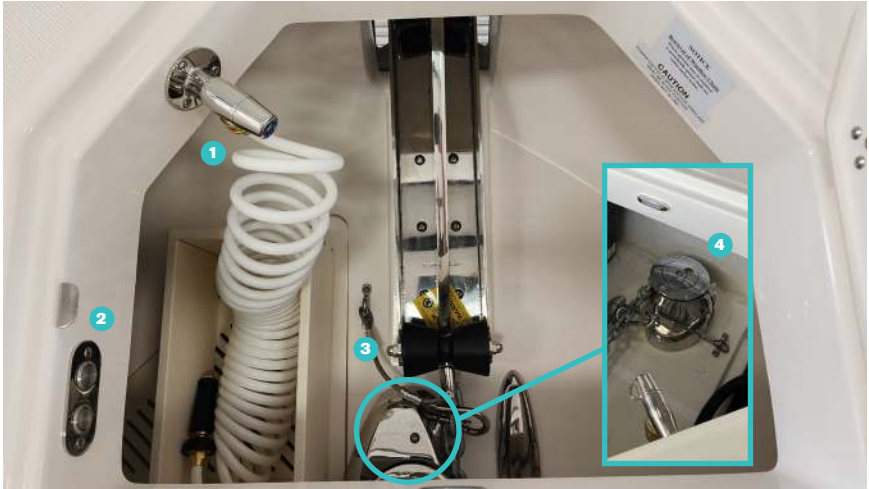

Anchor and Windlass

From the anchor locker, lower the anchor using the windlass electric motor or gravity. To lower the anchor using gravity, first remove the safety carabiner and loosen the clutch counterclockwise until the anchor starts to descend. The clutch key can be found in the storage under the forward bow seat. Apply clockwise pressure to the clutch to control the anchor's descent. Lower the anchor slowly to avoid damage.

- 1 - Freshwater Washdown
- 2 - Windlass Motor Buttons
- 3 - Safety Carabiner
- 4 - Windlass Clutch

When using the anchor buttons, first activate the windlass battery. Make sure the port side, yellow ACR switch on the starboard side of the anchor locker is set to 'on' or 'auto.' Press the forward anchor button to lower the windlass and the rear to raise.

Control the motor with the buttons inside the anchor locker or on the chartplotter via the DSS (see page 166). To operate the windlass via the DSS, navigate to the "Deck" page. Press and hold the anchor icon on the bow. Two arrows will pop up. Press the forward facing arrow to lower the anchor, and the aft facing arrow to raise.

There is a safety clutch on top of the windlass body. Tightening the clutch will tighten the hold on the anchor rode and loosening will release the hold. To tighten, insert the clutch key, stowed under the forward bow seat, and rotate clockwise. To loosen, rotate counter-clockwise.

To raise the anchor, first pilot the boat toward the anchor. Raise the anchor slightly to take up the slack created in the rode as the boat approaches the anchor. Stay close, but do not navigate the boat



Windlass clutch key location

past the anchor. Using Yamaha's StayPoint feature or Mercury's SkyHook feature may prove useful here. The rode should be close to vertical and perpendicular to the waterline. Once positioned, hold the aft facing arrow icon on the DSS or the aft button in the anchor locker until the anchor is raised.

Do not let the rode get tangled in the windlass. If the sound of the windlass changes abruptly before the anchor is fully retracted, inspect the anchor locker for a bind.

Once raised, reinstall the safety carabiner and close the anchor hatch to stow.

Do not use the windlass to pull the boat. Excessive strain on the windlass may cause damage. Improper operation of the anchor and windlass could cause damage to the vessel and is not included in your warranty.

The anchor is a heavy and potentially dangerous piece of equipment. When operating, keep all body parts and clothing clear of the windlass, the anchor, and the rode and have a spotter watch the anchor. Make sure the anchor is properly secured before embarking.



Pole insert locations

Bow SunShade System Option

To install the Bahama SunShade, first install the four poles into each of the rod holders in the gunwale around the U-shaped seating area.

Run the ropes attached to the front of the shade through the eyelets at the top of each pole.

Next, clip the other end of the shade to the eyelets on the front of the hard top. Pull on the ropes to tighten.

Once tightened, tie each rope off to the cleat attached to the bottom of each pole.

The SunShade poles are telescopic. Once the SunShade is installed, raise or lower the poles to the desired height.

Uninstall the SunShade before cruising.

Scan the QR codes included with the poles to access installation instructions and YouTube videos directly from the manufacturer.

Bow Seating Options

For the options in the bow area, the assembly remains the same as the aft cockpit options with the table and/or rocket launcher (see page 74).

The base can be found under the starboard seating in the storage compartment. The support post can be found underneath the forward bow storage compartment, in the same place as the windlass clutch key mentioned on page 84.

Please ensure to slide out the support plates before unfolding and installing the bow table.



Base plate location

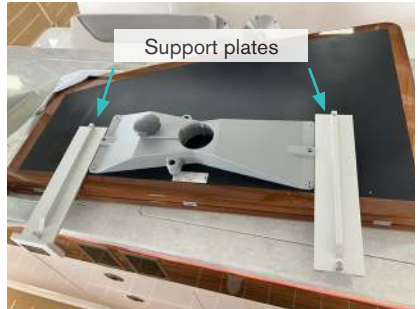

Bow table



Helm

The helm station varies depending on the chosen propulsion package. There will be a section dedicated to both Yamaha and Mercury packages, as well as a section afterwards detailing universal components regardless of chosen propulsion package. More importantly, the battery activation panel must be turned on before anything else.

Battery Activation Panel

This panel under the helm on the starboard side activates all 12v systems on the vessel. The button will remain lit while the batteries are on. Press the button again to turn the batteries off. This is necessary when storing the boat after each voyage.

For more information on smart battery management, refer to the “EGIS Modules” section on page 156.

Check the voltage of the DC batteries on the chartplotters once they have finished powering up. On the “Deck” page of the Digital Switching System (page 161), there is a battery icon in the top left corner. Tap it to see voltage levels for each battery and whether they are linked in parallel or not.



Battery activation panel

Helm - Yamaha

The helm station's layout and components will vary slightly, depending on the chosen propulsion package. Pictured below is the layout of the complete helm station with the Yamaha Helm Master EX installed. Refer to the manufacturer's owner's manual included in your welcome packet for specific engine operation, maintenance, and troubleshooting information.



- 1 - Triple Garmin Chartplotters
- 2 - Chiller Tub
- 3 - Fusion Stereo Control
- 4 - 12v Helm Breaker Panel (under)
- 5 - Wireless Charger
- 6 - Bow Thruster Controller
- 7 - Engine Ignition Panel
- 8 - Horn and Wiper Buttons
- 9 - Battery Activation Panel (under)
- 10 - Interceptor Control
- 11 - Digital Electronic Control (DEC) Throttle Shifter
- 12 - Maneuverability Joystick
- 13 - Garmin Remote Control Panel
- 14 - Yamaha Autopilot Control Panel
- 15 - VHF Radio
- 16 - Helm Seat Controls

Helm Assembly

Starting with Yamaha's Helm Master EX Package, option-specific components will be covered first. For more information, refer to Yamaha's Outboards web-site yamahaoutboards.com or global.yamaha-motor.com.



- 1 - CL5 Engine Data Display
- 2 - Docking Joystick
- 3 - Yamaha Throttle Shifter
- 4 - Ignition Panels and Key Fob

Starting Your Engine

Pre-Ignition Checklist

Perform the following safety and system checks before starting your engines:

1. Turn the batteries on from the battery activation panel.
2. Open the engine hatch and perform a 'sniff test' to check for fuel leaks and vapors. If you smell any fuel vapors, do not start the engines. Have your boat serviced by your Regal dealer before turning on the engines.
3. Check the exhaust vents on the convertible transom seat and UltraLounge for blockage. Remove any debris that may cause vapors to accumulate in the Lazarette compartment.
4. Run your bilge blowers for at least four minutes to clear any lingering vapors. To run your bilge blowers, tap the blower icons in the Digital Switching System (see page 160).
5. Check oil.
6. Check fuel levels. Remember the '1/3 Rule' (see "General Vessel Manual", page 36).
7. Make sure the throttle is in the neutral position.
8. Ensure clearance (of people and objects) before lowering the engines into the water.

WARNING

GASOLINE VAPORS CAN EXPLODE!
BEFORE STARTING ENGINE. PERFORM
SNIFF TEST AND CHECK BILGE
FOR GASOLINE LEAKS OR VAPORS.

WARNING

PREVENT INJURY OR DEATH
DUE TO FIRE OR EXPLOSION!
RUN BLOWER AT LEAST 4 MINUTES
BEFORE STARTING ENGINES.
RUN BLOWER BELOW CRUISING SPEEDS.

Ignition Panels

The ignition panel is under the steering wheel at the helm. Each engine has its own dedicated ignition button. To start the engines, begin by unlocking the ignition using the included Yamaha key fob. Once the ignition is unlocked, press the "Ignition" button to enable the ignition.

There are three ways to crank the engines.

1. Press each ignition "START/STOP" button individually to crank each engine separately.
2. Press the "START/STOP" button on the smaller ignition panel to crank the engines together.

3. Press the "START/STOP" button on the DEC throttle (see page 93) to crank the engines together.

To turn the engines off, press the "START/STOP" button(s) again.

After ignition, allow the engines to idle and warm up before embarking. While the engines are warming, check the engine compartment for any unusual sounds or conditions including visible fuel leaks.



Power switch, start/stop switch



Individual start/stop switch



Key FOB

Note: Layouts may vary.

Ignition Panel cont.



Note: Layouts may vary.

1 - High Water Alarm

The high water alarm will sound if there is too much water in the bilge. Refer to page 194 for more information.

2 - Gas Vapor Detection

This device will alert if there is a gas vapor leak. Refer to page 191 for more operational instructions.

3 - Extra power outlets

These outlets provide USB-A, USB-C, and a 12v, 10 amp socket for devices that cannot be powered or charged using the wireless sources on the dash. The protective covers flip upwards to access.

Helm Master EX - Throttle



The Yamaha propulsion option comes equipped with a twin control Yamaha EX Digital Electronic Control (DEC) throttle shifter. The left lever controls the port and center engines, while the right lever controls the starboard engine. This offers primary propulsion with the paired engines and precision steering and pivoting with the single engine.

Press the “Single Lever” button to control all engines together using the port-side lever only.

The “Center Engine” button allows control over the center engine only for slower trolling.

The “Speed Control” switch on the left side of the throttle lever maintains and adjusts speeds without moving the throttle. From any throttle position,

press “UP” or “DN” on the switch to adjust the boat’s RPMs in 500 RPM increments. To turn off speed control, move the levers either forward or back and the control will disengage.

There are five “Power Trim” switches on the throttle. There is a universal switch on the port-side lever. This switch raises or lowers the trim angle of all engines together. There are also three trim switches on the back of the throttle. Each switch raises or lowers the trim angle of each outboard individually.

The “Neutral Hold” button keeps the engines in neutral regardless of the throttle position. Moving the throttle forward or back while neutral hold is active, the engines will rev, and RPMs increase, but the boat will not move.

There is also a DEC alert indicator LED on the throttle that will illuminate if there is a communication issue between the throttle and the engines. If the light illuminates, have your boat serviced by your Regal dealer.



Yamaha throttle side view



Helm Master EX - Joystick



To engage the Yamaha Joystick, make sure the engine is running and the throttle is in neutral. Press the “JOYSTICK” button to activate the joystick. Press the button again to turn the joystick off.

Press the ‘plus’ and ‘minus’ adjustment buttons to adjust the joystick sensitivity.

There are three “SetPoint” buttons on the front of the joystick. Press the “STAYPOINT” button to automatically maintain the boat’s position and heading. This feature automatically uses up to Thrust Level 5 as needed.

Press the “DRIFTPOINT” button to maintain the boat’s heading, but allow the vessel to drift with the current. This is useful for drift-fishing a wreck or kite fishing.

Press the “FISHPOINT” button and the vessel will automatically keep the bow pointed into the wind or current.

Press each button again to turn the modes off.

For more information and visuals, visit global.yamaha-motor.com/business/outboards/products/accessories/hm-ex/ or yamahaoutboards.com/rigging/helm-master-ex.

Helm Master EX - Autopilot



Press “Heading Hold” to hold the boat’s compass setting. This will keep the boat pointed towards a consistent direction, though it is subject to drift from its projected path lane.

Pressing the “Course Hold” button will maintain both the direction and path lane, constantly adjusting and correcting for wind or current drift to stay on the intended course.

Press the “Track Point” button to automatically navigate the boat through a plotted path, using multiple waypoint pins as checkpoints for the boat to reach and then correct its course to follow the intended path.

The “Pattern Steer” button activates pre-selected patterns that are adjustable - Spiral, Zigzag, Pattern Search, and Williamson Turn - useful to find signs of fish at a target area.

For more information and visuals, visit global.yamaha-motor.com/business/outboards/products/accessories/hm-ex/ or yamahaoutboards.com/rigging/helm-master-ex.

Garmin Chartplotter Yamaha Page



Yamaha also provides an interface to be used in conjunction with the Garmin Multi-Function Displays (MFDs), or chartplotters. This provides extra tools such as Autopilot features, sonar, radar, etc.



Helm - Mercury

The helm station with the Mercury propulsion package is shown here. The most notable difference is that the Mercury Throttle Shifter contains the Autopilot Controls. Refer to the Mercury owner's manual included in your welcome packet for specific engine operation, maintenance, and troubleshooting information.



- 1 - Triple Garmin Chartplotters
- 2 - Chiller Tub
- 3 - Fusion Stereo Control
- 4 - 12v Helm Breaker Panel (under)
- 5 - Wireless Charger
- 6 - Bow Thruster Controller
- 7 - Engine Ignition Panel
- 8 - Battery Activation Panel (under)

- 9 - Horn and Wiper Buttons
- 10 - Interceptor Control
- 11 - Electronic Remote Control (ERC) Throttle Shifter
- 12 - Maneuverability Joystick
- 13 - Garmin Remote Control Panel
- 14 - VHF Radio/Storage
- 15 - Helm Seat Control

Starting Your Engine

Pre-Ignition Checklist

Perform the following safety and system checks before starting your engines:

1. Turn the batteries on from the battery activation panel.
2. Open the engine hatch and perform a 'sniff test' to check for fuel leaks and vapors. If you smell any fuel vapors, do not start the engines. Have your boat serviced by your Regal dealer before turning on the engines.
3. Check the exhaust vents on the convertible transom seat and UltraLounge for blockage. Remove any debris that may cause vapors to accumulate in the Lazarette compartment.
4. Run your bilge blowers for at least four minutes to clear any lingering vapors. To run your bilge blowers, tap the blower icons in the Digital Switching System (see page 160).
5. Check oil.
6. Check fuel levels. Remember the '1/3 Rule' (see "General Vessel Manual", page 36).
7. Make sure the throttle is in the neutral position.
8. Ensure clearance (of people and objects) before lowering the engines into the water.

WARNING

**GASOLINE VAPORS CAN EXPLODE!
BEFORE STARTING ENGINE. PERFORM
SNIFF TEST AND CHECK BILGE
FOR GASOLINE LEAKS OR VAPORS.**

WARNING

**PREVENT INJURY OR DEATH
DUE TO FIRE OR EXPLOSION!
RUN BLOWER AT LEAST 4 MINUTES
BEFORE STARTING ENGINES.
RUN BLOWER BELOW CRUISING SPEEDS.**

Ignition Panel

1 - High Water Alarm

The high water alarm will sound if there is too much water in the bilge. Refer to page 194 for more information.

2 - Extra power outlets

These outlets provide USB-A, USB-C, and a 12v, 10 amp socket for devices that cannot be powered or charged using the wireless sources on the dash. The protective covers flip upwards to access.

3 - Gas Vapor Detection

This device will alert if there is a gas vapor leak. Refer to page 191 for more operational instructions.

4 - Kill Switch

If the red lanyard is removed, this component shuts down the engines. Refer to page 134 for more information.



Triple engine model

Ignition Panel (cont.)

The ignition panel is under the steering wheel at the helm. Each engine has a dedicated ignition switch. To start the engines, insert each key into the ignition switches. When a key is in the ten o'clock position, the ignition is off. To prime the ignition, turn each key to 12 o'clock until it clicks once.

There are several options when cranking the engines.

1. Turn each key individually to two o'clock to crank each engine separately.
2. Press the "START ALL ENGINES/STOP" button on the port side of the Mercury shifter to crank the engines together (see following page).
3. Press the three "Start/Stop" buttons on the front of the Mercury shifter (see following page) to turn on each engine.

To turn the engines off, perform any of the above steps in reverse.



Mercury Throttle Shifter (ERC)



Triple engine model

The Mercury helm package comes equipped with a dual-handle, triple-engine Electronic Remote Control (ERC). The left lever controls the port engine and the right lever controls the starboard engine. The central engine will auto adjust to match the engine with the lowest throttle setting. If all engines are set at relatively the same speed, they will synchronize. Press the “1 Lever” button to control all engines together.

The screen in the middle of the throttle displays the status of advanced features like Active Trim. It will also display any faults that may occur.

Press the “Throttle Only” button to increase the engine RPM without shifting into gear.

The “Active Trim” button on the left side of the throttle automatically adjusts the angle of each engine to provide the optimal ride. There are arrow buttons above and below the Active Trim button. Use the arrows to select an Active trim profile. Each profile is a set of preprogrammed Active Trim parameters designed for specific situations. Adjusting the trim manually while Active Trim is engaged will turn Active Trim off.

For more information, refer to the Mercury Marine operation manual included in your owner’s package.

Mercury Joystick



To engage the Mercury Joystick, make sure the engine is running and the throttle is in neutral. A green ring around the joystick will illuminate when the joystick is activated. Use the '+' and '-' buttons on the front of the joystick to adjust the joystick steering sensitivity.

Press the "Route Mode" button to allow the boat to pilot itself to a waypoint selected on the chart plotter. Press the button again to disengage route mode.

Press the "SKYHOOK" button in the center of the throttle to maintain the boat's position and heading.

To activate "Auto Heading" Mode, put the boat into gear and then press the "Auto Heading" button. The boat will now maintain its current heading.

After engaging, adjustment lights will illuminate on the top of the throttle. Tilt the joystick left or right to adjust the heading 1° port or starboard respectively. Twist the joystick counterclockwise or clockwise to adjust the heading 10° port or starboard respectively.

The bow thruster is integrated into the Mercury joystick. When piloting the boat using the joystick, the thrust will engage for extra control when maneuvering. When integration is active, two orange lights above the "Adjust" button on the joystick will illuminate. To turn integration off, press the "Adjust" button on the joystick once. Only one orange light over the minus icon (-) will be illuminated.

Bow Thruster Controller



Operation

The bow thruster propeller is housed in the bow of the hull and pivots the bow to port or starboard. To turn the bow thruster on, press the on/off button on the front of the bow thruster joystick panel. Then, hold the button until a light on the panel flashes. A light on the panel will illuminate to indicate the joystick is on.

To operate the bow thruster, tilt the joystick left to push the boat to port or right to push the boat to starboard. Always ensure there are no swimmers in the area before using the bow thruster. Refer to the manufacturer owner's manual for specific operational instructions.

Maintenance

For periodic maintenance, inspect the propeller for debris and make sure it is aligned in the center of the hull tunnel and is not touching the walls. Do not operate the bow thruster when the boat is out of the water.

There is a bow thruster cut off icon in the top left corner of the DSS (see page 162). In the unlikely event of a runaway bow thruster, tap the icon to cut power to the bow thruster. There is also an EGIS module in the anchor locker on the port side. Turning the starboard switch to "Off" will also cut the power. Remember to return the switch to "Auto" once the bow thruster stops.

Triple Chartplotters

The three large screens on the helm dash are Garmin multifunctional displays (MFDs) that serve as navigational chartplotters and a main hub for all the boat's systems.

Each chartplotter has a power button on the bottom left corner. Tapping the button brings up a pre-set radar/GPS page and lowers the brightness. Repeatedly tapping it keeps lowering the brightness and then puts the screen to sleep. Holding the button brings up a menu in the top right of the screen to either manually sleep the display or turn off the entire chartplotter system around the vessel. Pressing it again will turn the system back on.

VHF Radio

Very High Frequency, or VHF, radios are used for distress signaling, ship-to-ship, and ship-to-shore communication. It is located in the storage console shown below. Channel 16 is the primary channel for ships in distress.

To make a distress call on the VHF-FM radio:

1. Make sure the radio is on.
2. Turn the radio to channel 16.
3. Press/hold the transmit button.
4. Clearly say, "Mayday, Mayday, Mayday."
5. Communicate:
 - Vessel name, HIN, and description
 - Position/location
 - Nature of emergency
 - Number of people on board
6. Wait 10 seconds. If there is no response, repeat steps.



Garmin Remote Control Panel



This panel allows remote control of the Garmin chartplotters, providing an easier way to navigate the screens when under rough conditions. The arrows on the far left change what display it is controlling. Use the wheel to scroll, pan, and select icons through the screen. The 4 buttons on the right end of the panel can be binded to preferred pages within the entire chartplotter system.

Chiller Tub

Shown in the picture below, the chiller tub is a refrigerated storage space to keep refreshments cooled and easily accessible. To activate, tap the snowflake icon on the “Deck” page of the Digital Switching System (page 163).



Helm Seat Controls

Use the buttons shown on the previous page to move the helm seats forward and aft, as well as adjust the height.

Horn and Wiper Buttons

The top button honks the horn and the bottom button activates the windshield wiper. It is not a toggle button; once the button is released, the wiper will deactivate. For more wiper controls, see page 162.



Note: Layouts may vary.

Fusion Stereo

The Fusion stereo system is the central hub for the audio entertainment system. The primary dedicated control unit is located on the helm dash and is shown below.

The Fusion stereo system is also fully integrated with the chartplotters. Control the entire audio system including independent control of all sub woofers, mix balance, and volume for individual audio zones. Navigate to the “Media” page in the helm chartplotters. Tap the “Layout” icon at the bottom of the helm chartplotter home screen and scroll through the available icons until you find the “Media” page.

The Fusion audio unit is waterproof and is engineered for the marine environment. Sub woofers and speakers are also waterproof and designed to provide optimal sound quality outdoors and on the water.

The Fusion stereo supports a variety of source and input options including, but not limited to Bluetooth, USB, AUX, AM/FM and Sirius Satellite radio (subscription not included). Refer to the manufacturer owner’s manual included in your welcome packet for more information on functionality and operation.



Humphree Lightning

There are two Humphree Lightning interceptors mounted to the transom on either side of the engines. This provides an automatic trim and stabilization system by extending and retracting the stabilization blades to manipulate water flow under the boat.

The Humphree Lightning System on the boat comes with the Comfort Package pre-installed, which comprises of three auto-adjustment programs: Auto Trim, Auto List, and Pitch Control. These features can be toggled on or off from the Humphree control display at the helm dash.

Control the boat's trim and list manually from the Humphree control panel. Drag your finger left and right along the panel to adjust the list. Drag your finger up and down to adjust the trim angle.



Interceptor and display

Auto Trim uses the interceptors to adjust the planing angle of the bow and achieve the best running angle at any speed. This feature has been customized by Regal to fit the boat, however these values can be easily altered to further customize the boat's ride.

Auto List deploys the interceptors to compensate for list and keep the boat at an even keel while running. For example, if the boat is listing toward port, the port interceptor will extend to lift that side of the boat.

Pitch Control continually adjusts the interceptors to compensate for rough or choppy seas and keep the bow as steady as possible for a safe and smooth ride.

There are four levels of software packages for the Humphree Lightning system. The software can be upgraded. Contact your Regal dealer for assistance.

Refer to the manufacturer owner's manual included in your welcome packet for specific operating instructions.

12v Helm Breaker Panel

A DC current breaker panel is installed on the starboard side of the helm underneath the steering wheel. When a breaker trips, a button on the panel pops out. To reset the breaker, push the button back in until it clicks. The emergency parallel button links all DC batteries. This is a last-resort feature and should not be used unless an emergency has presented itself. For more information on smart battery management, refer to the EGIS modules on page 156.

The panel to the right of the breaker panel is a thermostat controller for the chiller tub on the dash.

Additionally, there is a Mercury diagnostic receptacle for service technicians to access. For Yamaha propulsion, the receptacle is located on the back face of the throttle shifter.

There is also a Garmin input receptacle to update the Garmin chartplotters. Please contact your Regal dealer for service in these areas.

Adjustable Steering Wheel

Manually adjust the steering wheel angle and height in the same way for a car's steering wheel. Disengage the locking tab by pushing it forward, shift the steering wheel to the desired angle, and then re-engage the lock.



Locking tab



Radar



This option comes equipped with a Garmin Fantom 4' Open Array radar installed on the hardtop. The radar system is designed to assist navigation in low visibility situations by locating land masses, other boats, and incoming weather.

The radar system is controlled from the chartplotters at the helm (see page 157). Tap the "Layout" icon in the bottom center of the home page to pull up the horizontal icon scroll. Tap on the word "Radar" to bring up the radar layouts. On the radar page, there is an icon labeled "X-mit" or 'transmit'. Tap the icon to activate the radar.

Once the radar is active, the radar antenna on the hardtop will start spinning and the radar page will begin displaying readings.

FLIR Thermal Camera

This option comes equipped with a FLIR M232 Pan & Tilt Thermal Camera attached to the hardtop. The FLIR camera is a thermal camera that provides enhanced visibility when piloting the boat at night, in stormy weather, and in other low visibility conditions. Access the FLIR camera feed by tapping the "Video" icon on the helm plotter home screen and then selecting the FLIR camera from the input list. Tap the arrows in the bottom left corner of the screen to control the tilt and pan of the FLIR camera.

Control the camera by dragging your finger across the screen to pan and tilt and pinch to zoom. The camera has a 360° range of motion.

Embarking

After warming the engines, you are ready to embark. Push the throttle forward to accelerate forward or pull the throttle aft to reverse.

When operating the throttle, use smooth and deliberate movements. Do not shift abruptly from forward to reverse or vice-versa. Do not shift into forward or reverse while running the engine at high RPMs.

Ensure you have unobstructed visibility in front of and behind before accelerating or reversing.

Review the “Rules of the Road” chapter of the General Vessel manual before piloting the boat.



Hardtop

After having activated the DC batteries, the chartplotters should turn on and at least one of them should show the DSS page. Navigate to the hardtop page to access all the hardtop features and components.



Note: Layouts may vary.

1 - PowerShade Control

5 - Forward Lightbar Toggle

2 - Navigation Lights

6 - Bow Access Window Control

3 - Overhead Cockpit Lighting

6 - RGBW Lighting Control

4 - Sunroof Control

7 - Cockpit TV Control

PowerShade

The PowerShade provides shading to the Aft Cockpit and extends from the back of the hardtop. To extend the PowerShade, tap the extend arrow. To retract the PowerShade, tap the retract arrow. Do not extend the PowerShade (or PowerPlatform) while underway.



PowerShade extended

Navigation Lights

Tap the “NAV LIGHTS” icon to toggle the running navigation lights. Tap a second time to turn on the anchor light. A third tap will turn off the lights.

Overhead Cockpit Lighting

Use the slider to control the intensity of the overhead lighting in the cockpit.

Sunroof Control

Use the corresponding arrows to open or close the sunroof.

Rinse out the sunroof tracks periodically to remove grime and debris. Do not apply lubrication to the sunroof tracks.

Remember to close the sunroof when leaving the boat unattended for extended periods. Damage resulting from improper sunroof operation and maintenance is not included in your warranty.



Sunroof retracted

Forward Lightbar Toggle

Tap the lightbar icon to toggle the forward lighting on and off.

Bow Access Window

Use the corresponding arrows to open and close the window panel that allows access to the bow section.

RGBW Lighting

Tapping the color wheel toggles the RGBW lighting around the vessel. Tapping the gear icon brings up a control panel for RGBW lighting only.

Cockpit TV

The 43” cockpit television drops down from the ceiling above the refreshment island. Tap the TV arrow icons on the “Hardtop” page in the DSS to raise or lower the television.



Cockpit TV in “down” position

Outriggers

As an option, outriggers are installed on the hardtop, on the port and starboard edges.

In the first photo shown below, turning clockwise (facing upwards) raises the outrigger and increases the angle from horizontal. Turning counter-clockwise lowers the outriggers to horizontal. Flipping the crank handle to its alternate orientation allows it to rotate the direction the outrigger faces.

To stowaway, make sure the outrigger is facing aft and completely horizontal.



Cabin

The cabin entrance is on the port side of the helm controls. To access, navigate to the “Deck” page on the DSS (page 160). Press on the lock icon to access a numberpad pop-up. The default lock code is 0123. To change the code, tap the “Change Password” icon at the bottom of the lock pop up window and follow the on-screen instructions.



Cabin Door

The cabin door is controlled from the Deck page in the DSS or with the buttons on the side of the door. When open, the door slides behind the helm and is hidden away from sight.



DSS cabin numberpad

Manual Cabin Door Release

In the event the cabin door does not receive power for any reason, there is still a way to open and close the cabin door manually, from both the inside and outside.

From the outside, first remove the upholstery panel hiding the track, as shown to the right. Next, pull the right side of the lever towards you to retract the pin from the electric slider on the track.

Once the lever is disengaged as shown in the second photo, the cabin door is free to move.

To reengage, simply close the cabin door fully and pull the electric slider towards the pin. However, the easiest way is to activate the electric slider whenever there is power again, as it'll automatically latch the door once it makes contact.

To manually open the cabin door from the inside, simply pull the handle on the right to disengage the mechanism.



Cabin door engaged

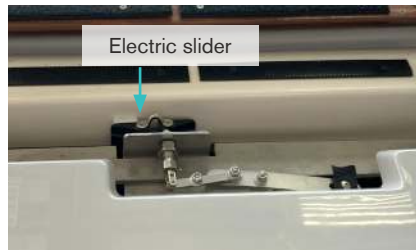

Cabin door disengaged



Manual release (from inside)

V-berth

The cabin can be divided into 3 distinct spaces: the V-berth (pictured below, bow-facing), the Mid-berth (aft-facing), and the head.



- 1 - Cabin Controls, Chartplotter, & Air Conditioning Thermostat
- 2 - Microwave
- 3 - Alternating Current, AC, Main Distribution Panel (behind seating)
- 4 - Storage compartments & Bow Equipment
- 5 - Head
- 6 - Base plate options (Filler cushion or table OPTION)
- 7 - Engine Batteries

Cabin Control Panel

This button panel toggles all lighting within the cabin, as well as controls the cabin door from the inside.

Cabin Chartplotter

The cabin display on the port side wall of the cabin entrance has limited DSS function compared to the helm plotters. It controls the cabin lighting and shows fluids levels. It can still access other pages outside of the DSS.

A/C - Air Conditioning

Control the vessel's air conditioning system with the thermostat display next to the cabin display previously mentioned. To activate the system, refer to page 190.

Refer to your manufacturer owner's manual for specific operating instructions.



Port wall of cabin entrance

AC Main Distribution Panel (MDP)

The AC Main Distribution Panel, or MDP, protects all high voltage alternating current components. The MDP controls the power flow from the power source and protects the air conditioning, water heater, cooking and entertainment appliances, and more. It contains all physical AC breakers and is behind the port side flip down seating in the V-berth.



Port side flip down seat



Port side seat opened



Note: Layouts may vary.

Amenities and Options

On the port side of the cabin near the steps is a microwave and various storage cabinets and compartment. Additional storage compartments are under the V-berth seats, as well as the base plate for the table and/or cushion options for the cabin. The support post is also stored in the same area.

The cushion can be found in the forward-most compartment, behind the backrest. To access, pull the backrest from the bottom, rotate upwards and slide in towards the bow.



Filler cushion location



Bow Battery and Bow Thruster

The 24v bow battery dedicated to the anchor locker and bow systems is found in the forward-most V-berth compartment, just under the filler cushion location. To access, refer to page 149.

Engine Batteries

Depending on the chosen propulsion package, each engine will have a dedicated battery to start the engines. They can be found in the flooring under a hatch between both berths.



Battery and bow thruster motor



Engine batteries

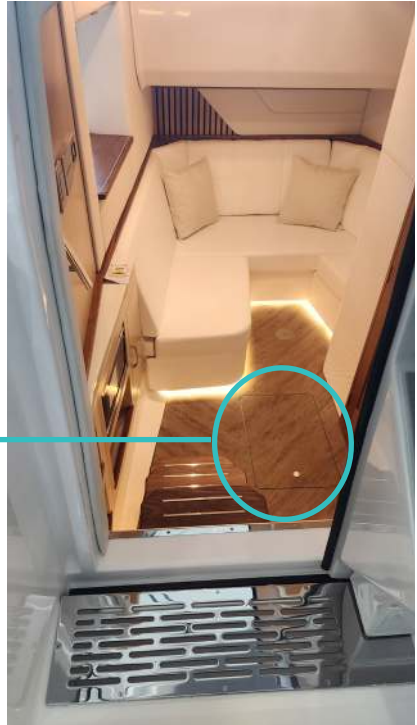

Engine batteries location

Water Heater

The onboard water heater can reach a max temperature of 125 °F. The water heater holds 5.3 gallons; do not expect hot water to last as long as in your home. Take shorter showers to conserve hot water and onboard freshwater in general. For more information, refer to page 180.



Water heater access panel

Entertainment Access Panels

Upon entering the cabin, on the port side near the microwave is a few storage compartments for miscellaneous items. On the back wall of these spaces are access panels for most entertainment features.



Microwave and access panels

In one of these compartments is the coaxial cable connection and a power outlet as well. Below that, is another access panel for electronics wiring and components.



Electronics access panels and connections

Head

The head contains a fully functional toilet, shower, and sink, all of which pull from the freshwater system (page 174). Both the shower and sink drain through the shower box, while the toilet drains to the waste tank. Additionally, the entire freshwater system can run on shore water input, instead of the limited freshwater tank.

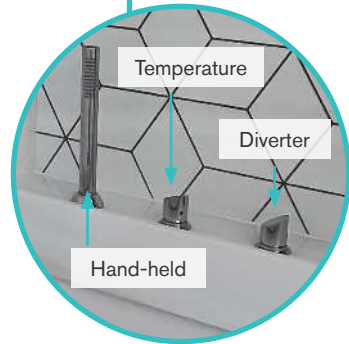
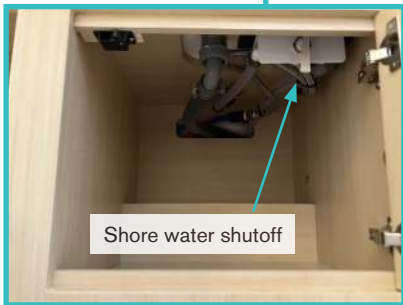

Shower

As shown above, the shower has two control handles and one hand-held shower head. There is also a waterfall shower head above. To operate the shower, refer to page 178.

Water drains through the floor grate and down into the shower box (see page 179). An automatic pump in the engine compartment then evacuates the water overboard or into the waste tank if the optional gray water system is included. Refer to page 179 for more information on the shower box and pump.

Clean the drain screen periodically to avoid clogging.

Use the latch at the top of the glass shower door to secure the door when the vessel is in motion.



Shore Water Shutoff Valve

While connected to an external source, the shutoff valve located under the sink in the head controls whether the freshwater tank is open or closed, allowing it to fill up or allowing the freshwater system to pressurize and run on shore water instead of the limited tank.

When the valve handle is turned to the right (open), water will fill the onboard freshwater tank. When the valve handle is turned downwards (closed), the system will pressurize and pull water directly from the onshore source instead of the tank. Turn the onshore water supply on and check the hose and connections for leaks.

The boat's freshwater system is designed for **non-potable water use only** and is not suitable for drinking or cooking. Please use bottled or treated water for all human consumption.

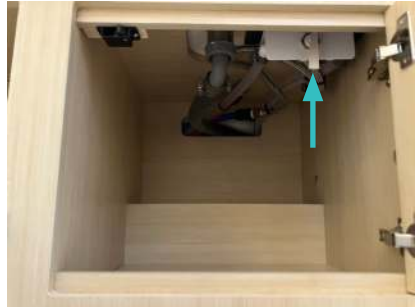

Shore water shutoff valve

NOTICE



Open valve to fill freshwater tank from shore water inlet.



Close valve when tank is full.

Sanitizing the freshwater system remains a priority to prevent bacterial growth and maintain water quality for showering and washing dishes. For more detail on the sanitization process, please refer to page 183.

Mid-Berth

The mid-berth has a 32-inch TV, multiple storages, and the ability to convert the two twin beds into a king sized bed. The backrest shown below doubles as the filler cushion that fits right in to the bed frame ledges for easy support—no need for a base plate or other supports. On the port side are the house and electronics batteries (see page 150 for access), with the shower box access visible on the bottom edge of the photo.

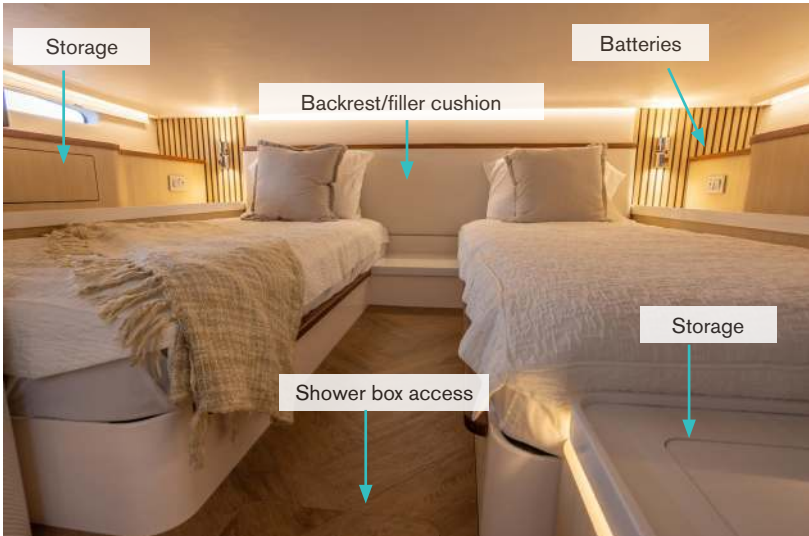

Cabin Television

The cockpit and mid-berth cabin televisions run on AC power. Turn on the “ENTERTAINMENT” breaker on the MDP in the cabin before using the television.

The boat comes equipped with a limited range air antenna that provides limited channel options while the vessel is docked or close to the shore.

The television system comes with two HDMI inputs in the stateroom media cabinet. There are two shelves available for accessories to use with the television including game consoles, DVD players, or other third party streaming devices. After connecting your accessories to the HDMI ports, navigate to the inputs using the television remote and select either “HDMI 1” or

“HDMI 2.” The HDMI ports utilize a splitter to route a signal to all the televisions and plotters on the boat.

KVH Satellite

The boat may come equipped with the optional KVH satellite system. The KVH satellite system can connect to satellite television, whether you are docked or offshore, and works with any third party satellite television subscription. Regal does not provide a satellite TV subscription or the third party equipment to access satellite television. The KVH satellite package only includes the hardware necessary to receive a satellite signal.

With the KVH satellite package, make sure to contact a third party satellite television provider for subscriptions and any accessory installation necessary to access your subscription.

The KVH system runs on DC power. Make sure the DC battery bank is turned on before attempting to operate the TV using a satellite signal. Power on the TV using the included remote. The KVH system will be wired through the “HDMI 1” port (thus removing one of the ports

for use with a third party accessory). Use the remote to navigate to the input menu on the TV and select “HDMI 1” to access your satellite television.

Refer to the included TV and satellite owners manual for more specific operating instructions.



CO and Smoke Detectors

Carbon monoxide, CO, is toxic in any quantity and deadly in high concentrations. The boat comes equipped with two, combo CO/ smoke detectors that monitor gas levels and will sound an alarm when CO or smoke concentration in the cabin reaches levels that are unsafe. Both detectors are on the starboard side – one near the storage compartment covering the A/C unit and one next to the cabin television.

Refer to the General Vessel manual for more information about the dangers of CO poisoning and how to avoid potential CO accumulation. Refer to page 193 for operational information.



Mid-Berth CO/smoke detector



V-Berth CO/smoke detector



CO/smoke detector up-close



TECHNICAL GUIDE

Systems Introduction

After the physical walkthrough, the following is an operational and component overview of the Regal LX43's systems. It is important that you, the owner, understand how to operate the boat and how the boat's systems work. Adequate understanding is crucial to operational safety, maintenance, and upkeep. For more specific information on third-party components, refer to the manufacturer owner's manual for that component included in your welcome packet.

This section will cover Propulsion, Electrical, Digital, Fluids, and Safety systems, as well as a section dedicated to Care and Maintenance for your vessel.



Propulsion

The following section includes a basic overview of the propulsion and fuel system as well as an operational introduction to each propulsion package. Refer to the respective owner's manual included in your welcome packet for specific engine operation, maintenance, and troubleshooting information.

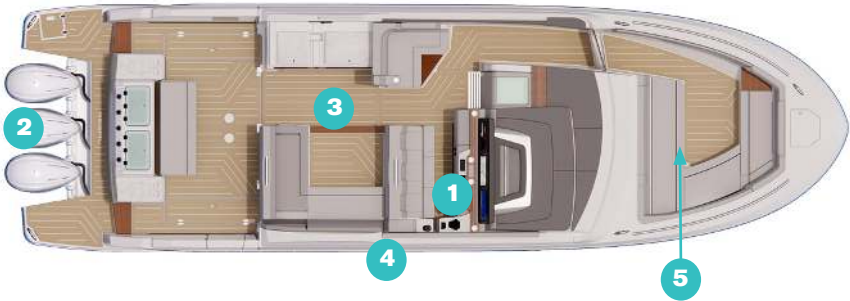

Note: Layouts may vary. Mercury package pictured.

- 1 - Helm Controls
- 2 - Engines
- 3 - Fuel Tank (in hull)
- 4 - Fuel Tank Fill Cap
- 5 - Bow Thruster Propeller (in hull, underwater)

⚠ WARNING

PREVENT INJURY OR DEATH!
READ ALL MANUFACTURER'S ENGINE AND
PROPULSION OWNER'S MANUALS BEFORE
OPERATING THE VESSEL.

⚠ WARNING

PREVENT INJURY OR DEATH!
ALWAYS STOP THE ENGINE(S)
BEFORE PERFORMING
ANY ENGINE MAINTENANCE!

Components

Fuel

There are typically three fuel fills in the starboard gunwale, two of which are labeled “GAS”. With a generator as part of the electrical system, the third is “DIESEL”. Do not fill the tank with the engines running. Improper fueling is not included in your warranty.

A charcoal canister fitted to the fuel vent absorbs fuel vapors in compliance with EPA and CARB regulations. Absorbed vapors and particulates will drain back down into the fuel tank. When filling the tank, keep an eye on the fuel gauge on the “Engine” page of the chartplotters (see “Garmin Chartplotters” on page 157).

WARNING

**PREVENT INJURY OR DEATH!
FUEL VAPORS ARE A FIRE AND EXPLOSION
HAZARD. DO NOT STORE FUELS,
FLAMMABLE LIQUIDS
OR PORTABLE FUEL TANKS ON BOARD!**

Oil

Engines need oil to lubricate internal mechanisms. Refer to the engine manufacturer’s owner’s manual for specific details on recommended oil types and the maintenance schedule.

Changing a boat’s oil is more complicated than changing a car’s oil. Have the dealer change the oil when you take the boat in for regular maintenance.

NOTICE

**DO NOT OVERFILL THE FUEL TANK!
THIS HELPS AVOID ANY OVERBOARD
SPILLS WHICH MAY HARM THE
ENVIRONMENT.**

CAUTION

**AVOID ENGINE DAMAGE OR FAILURE!
CHECK ENGINE/DRIVE OIL LEVELS
BEFORE EACH OUTING. IF LOW ADD
APPROPRIATE OIL TYPE AND QUANTITY.**

Cooling

The engines use raw water for cooling. Impellers in the engines pump raw water through the cooling system. Service periodically according to the manufacturer's instructions.

Do not start the engines dry. If the outdrives are not submerged, the cooling system will not take in water to cool the engine which could cause overheating and damage. Always make sure the outdrives are fully submerged before starting. Starting the engines dry is not included in your warranty.

⚠ WARNING

**PREVENT INJURY DUE TO HOT LIQUIDS!
DO NOT OPEN THE COOLANT CAP
WHEN THE ENGINE IS HOT AS STEAM OR
HOT ANTI-FREEZE COULD CAUSE BURNS!**



Exhaust

Exhaust is expelled directly from the engines above and below water. Natural and power ventilation built into the Lazarette compartment expels any vapors that may accumulate.

Power ventilation utilizes bilge blowers to clear fumes from the engine compartment.

There are exhaust vents on the aft side of the convertible transom seat, above the port and starboard speakers. The port side vents are attached to blowers that move air through the Lazarette compartment. Before embarking, check the exhaust vents for any blockage to prevent potential CO poisoning.

For the UltraLounge, exhausts are located on the base of the structure, on the port and starboard faces.



⚠ WARNING

PREVENT INJURY OR DEATH!
ETHYLENE GLYCOL COOLANT IS
POISONOUS TO HUMANS AND ANIMALS
IF INGESTED. DISPOSE OF ALL COOLANT IN A
ENVIRONMENTALLY FRIENDLY WAY.

⚠ CAUTION

AVOID EYE IRRITANT POTENTIAL!
WEAR EYE PROTECTION
WHEN WORKING WITH COOLANT.
WEAR GLOVES & WASH HANDS OFTEN!

⚠ WARNING

AVOID A POSSIBLE ACCIDENT CAUSING
INJURY, DEATH OR PROPERTY DAMAGE!
NEVER USE A STANDARD PROPELLER
ON A COUNTER ROTATION ENGINE, OR A
COUNTER ROTATION PROPELLER ON A
STANDARD ROTATION ENGINE. THE VESSEL
COULD TRAVEL IN AN UNEXPECTED
DIRECTION.



Kill switch example

Propellers

Regal has selected the ideal propellers for the selected propulsion package.

Periodically check the propellers for:

- Loose, missing, or corroded hardware.
- Nicks, dings, or missing propeller material.
- Bent blades.
- Debris wrapped around the blades.

Kill Switch

In the event of an emergency, a kill switch is located near the ignition panel under the steering wheel (shown below). The boat will come with a red lanyard to attach to the kill switch, should the captain be thrown overboard or knocked down. Please ensure you are fully aware of where this is located as it may save lives while out on the water.

Starting Your Engine

Pre-Ignition Checklist

Perform the following safety and system checks before starting your engines:

1. Turn the batteries on from the battery activation panel.
2. Open the engine hatch and perform a 'sniff test' to check for fuel leaks and vapors. If you smell any fuel vapors, do not start the engines. Have your boat serviced by your Regal dealer before turning on the engines.
3. Check the exhaust vents on the convertible transom seat and UltraLounge for blockage. Remove any debris that may cause vapors to accumulate in the Lazarette compartment.
4. Run your bilge blowers for at least four minutes to clear any lingering vapors. To run your bilge blowers, tap the blower icons in the Digital Switching System (see page 160).
5. Check oil.
6. Check fuel levels. Remember the '1/3 Rule' (see "General Vessel Manual", page 36).
7. Make sure the throttle is in the neutral position.
8. Ensure clearance (of people and objects) before lowering the engines into the water.

WARNING

**GASOLINE VAPORS CAN EXPLODE!
BEFORE STARTING ENGINE. PERFORM
SNIFF TEST AND CHECK BILGE
FOR GASOLINE LEAKS OR VAPORS.**

WARNING

**PREVENT INJURY OR DEATH
DUE TO FIRE OR EXPLOSION!
RUN BLOWER AT LEAST 4 MINUTES
BEFORE STARTING ENGINES.
RUN BLOWER BELOW CRUISING SPEEDS.**

Embarking

After warming the engines, you are ready to embark. Push the throttle forward to accelerate forward or pull the throttle aft to reverse.

When operating the throttle, use smooth and deliberate movements. Do not shift abruptly from forward to reverse or vice-versa. Do not shift into forward or reverse while running the engine at high RPMs.

Ensure you have unobstructed visibility in front of and behind you before accelerating or reversing.

Review the “Rules of the Road” chapter of the General Vessel manual included in your welcome packet before piloting your boat.



Electrical

The LX43 electrical system uses both direct (DC) and alternating (AC) current. Depending on the selected electrical package, your vessel will vary in terms of charging, power conversion, power sources, and physical layout. All electrical components are circuit-protected. Most breakers are turned off before your boat is delivered. Make sure all breakers are turned on when you take ownership of the boat.



- 1 - ELCI (in storage tub)
- 2 - Generator (in Lazarette comp.)
- 3 - Battery Management Box (in Lazarette comp.)
- 4 - PowerBank Option (in Lazarette comp.)
- 5 - Battery Activation Panel (under helm or Mezz. seats for early models)
- 6 - 12v Helm Breaker Panel (under helm controls)
- 7 - Batteries (in berths)
- 8 - AC Main Distribution Panel (in cabin)

⚠ WARNING

**PREVENT SEVERE INJURY OR DEATH!
DISCONNECT ALL ELECTRICAL POWER
SOURCES BEFORE ATTEMPTING TO
REPAIR OR REPLACE ANY
ELECTRICAL COMPONENT.**

Battery Activation Panel

This panel under the helm on the starboard side activates all 12V systems on the vessel. The button will remain lit while the batteries are on. Press the button again to turn the batteries off. This is necessary when storing the boat after each voyage.

For more information on smart battery management, refer to the “EGIS Modules” section on page 156.

Check the voltage of the DC batteries on the chartplotters once they have finished powering up. On the “Deck” page of the Digital Switching System (page 160), there is a battery icon in the top left corner. Tap it to see voltage levels for each battery and whether they are linked in parallel or not.



Battery activation panel

Generator Only

If the generator option is selected, this will be the main source of AC power. The generator is always located in the Lazarette compartment, towards the aft section.

Diesel generators come with sound insulation capsules to control noise. Refer to the General Vessel manual's "Exhaust and Carbon Monoxide" section for generator safety guidelines before operating.

The generator pulls fuel from a dedicated 26-gallon diesel tank. The diesel system includes two fuel filters that keep debris out of the generator. The first is an in-line filter located close to the generator. The second is a cartridge style filter on the generator itself.

Cooling

The generator uses raw seawater for cooling. All seacocks are located in the center of the Lazarette compartment. The generator has a dedicated seacock separate from the central manifold (see "Seacocks" on page 185).

There is a strainer located along the raw water line that catches debris and keeps the generator clean. To check the strainer basket, first make sure the seacock is closed. Next clear the strainer by removing the strainer top, strainer basket, and dumping out any debris. Replace the basket by pushing it down evenly into place and tightening the strainer top. Reopen the seacock. Periodically check the strainer basket for debris.

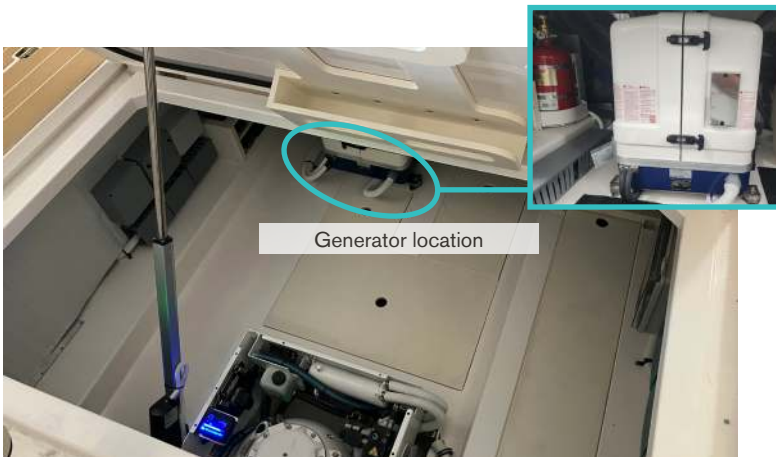

Note: Layouts may vary. Generator only option pictured.

The generator also uses chemical coolant, located in the coolant reservoir near the generator, to avoid overheating. The coolant reservoir is marked to indicate the optimal fill level; consistently check coolant levels to help ensure smooth performance. Refer to your generator owner's manual for upkeep and maintenance schedules.

Starting the Generator

Turn the generator on manually using the dedicated generator activation panel near the MDP, the switch icon within the Switching page, or the generator icon at the top of the Digital Switching page. Simply press the icon in the top left header.



Generator coolant reservoir

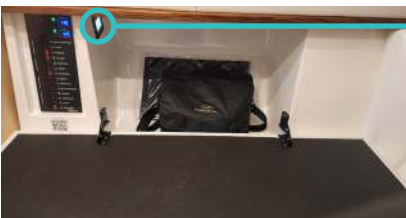

Auto-Transfer Box

The generator also contains an Auto Transfer box that activates upon connecting to shore power. It is located in the Lazarette Compartment on the port-side bulkhead (see next page).



Switching page icon



Digital start icon



Physical control panel

The Auto-Transfer Box acts as a connector between the generator and shore power to control current flow and prevent overload. It has 3 modes - shore only, generator only, and auto-mode. Auto-mode switches between the generator and shore power automatically if a shore power source is detected. This no longer requires manual switching through the MDP.



Auto transfer box

Mastervolt ChargeMaster Plus

Four Mastervolt ChargeMasters use AC current from the generator or shore power to charge the DC battery bank, which includes the house, electronics, and engine batteries.



ChargeMaster

Mastervolt MacPlus

For this option, the MacPlus unit is a DC converter that adjusts voltage from the 12v bank to the 24v bow battery. This option will only have one unit.



MacPlus



PowerBank Only

Regal's PowerBank consists of four 24v lithium batteries, first wired in series and then parallel to create two 48v power banks. Turn the PowerBank on by tapping the "Lithium ON" icon within the dedicated "Switching" page. The PowerBank must stay activated to charge using shore power; it will automatically activate when shore power is connected. Be sure to turn off the PowerBank when storing the vessel for extended periods of time.



CombiMaster unit



Switching page icon

Mastervolt CombiMasters

The PowerBank uses two 48v CombiMasters which act as inverter/chargers to take DC power from the PowerBank and invert it to power the 120v devices at the MDP. When plugged in to shore power, they can act as chargers for the PowerBank or pass power directly through them to run the MDP off shore power rather than using the PowerBank. However, the more loads present, the less charge to the batteries will be received. It is possible that even with shore power in, the 120v loads are more than the incoming charge, so the CombiMasters will still need to invert to make up for the power, and therefore will not be charging the PowerBank.

Mastervolt MacPlus

Mastervolt MacPlus units convert DC voltage between the 48v and 12v batteries. There are 4 MacPlus units; one is a 48/24v converter which charges the 24v bow battery using the 48v PowerBank. The other 3 are bidirectional 12/48v converters that connect all 12v AGM batteries to the 48v Lithium PowerBank. They can charge the PowerBank using the engine alternators if the engines are running above 1100 RPM. However, the priority is always ensuring the engine batteries have charge. For more information on smart battery management, see “EGIS Modules” on page 156.



MacPlus unit

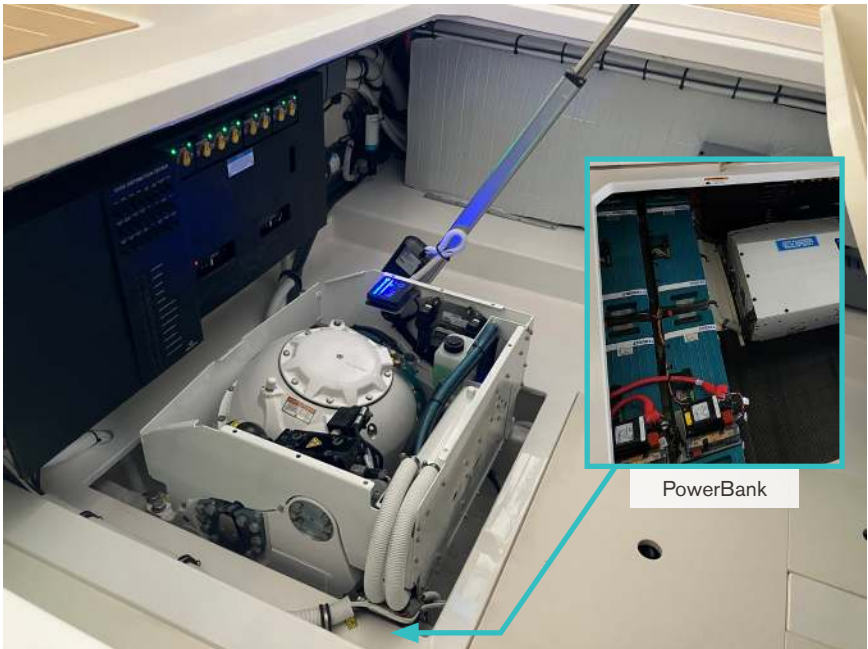

LivePower System

Designed to eliminate as much manual operation as possible, the LivePower System includes both the PowerBank and a 5kW 48v DC generator. With this option, the PowerBank is the primary power source.

Mastervolt CombiMasters

The LivePower system uses two 48v CombiMasters to take DC power from the PowerBank and invert it to power the 120v devices at the MDP. When plugged in to shore power, they can act as chargers for the Lithium Bank or pass power directly through them to run the MDP off shore power rather than using the Lithium Bank.



CombiMaster unit

Mastervolt MacPlus

Mastervolt MacPlus units convert DC voltage between the 48v and 12v batteries. There are 4 MacPlus units; one is a 48/24v converter which charges the 24v bow battery using the 48v PowerBank. The other 3 are bidirectional 12/48v converters that connect all 12v AGM batteries to the 48v Lithium PowerBank. They can charge the PowerBank using the engine alternators if the engines are running above 1100 RPM. However, the priority is always ensuring the engine batteries have charge. For more information on smart battery management, see "EGIS Modules" on page 156.



MacPlus unit

5kW 48v DC Generator

The generator's main function in this option is to charge the PowerBank. It can be activated through the DSS, Switching page, or the dedicated generator panel near the MDP in the cabin.

With the LivePower system, there is an "Auto-Gen" feature that can be toggled within the Switching page. Once the PowerBank charge is below 20%, the generator will take over to charge the PowerBank until it reaches 80%. The auto-gen feature will turn on automatically when the boat is turned on. It is recommended to turn off the auto gen only when storing the boat for long periods. When operated properly, the only concern will be diesel fuel levels.

Connecting to shore power will disable the Auto-Gen feature.

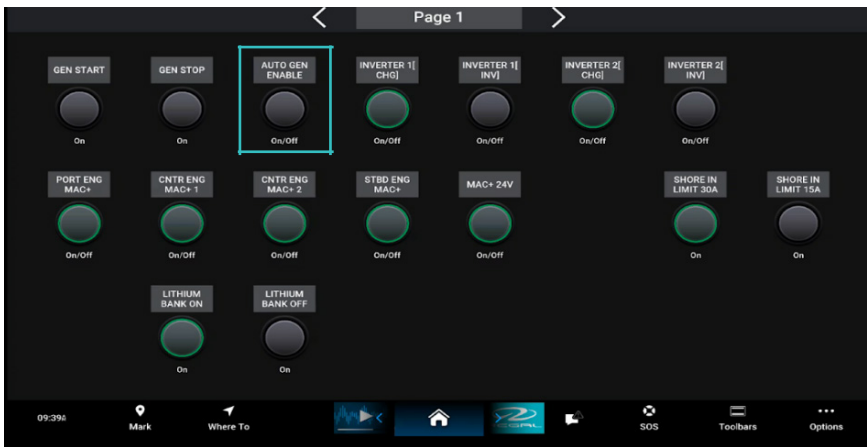

Auto-Gen icon

Shore Power

The retractable 50 amp shore power reel connects to a marina's shore power tower to supply the boat's 120v AC system through the Main Distribution Panel (see page 119 & 154). It is located on the aft face of the transom, on the lower port-side edge of both the convertible transom seat and the UltraLounge. Simply pull-out to the desired length and connect to the marina's shore power tower. To retract, use the button located in the stern anchor compartment (see below).

On models equipped with the PowerBank or LivePower systems, any excess power will also be used to charge the Lithium batteries. Specific to Live Power systems, shore power connection will disable the auto-generator feature.

Convertible transom seat



UltraLounge

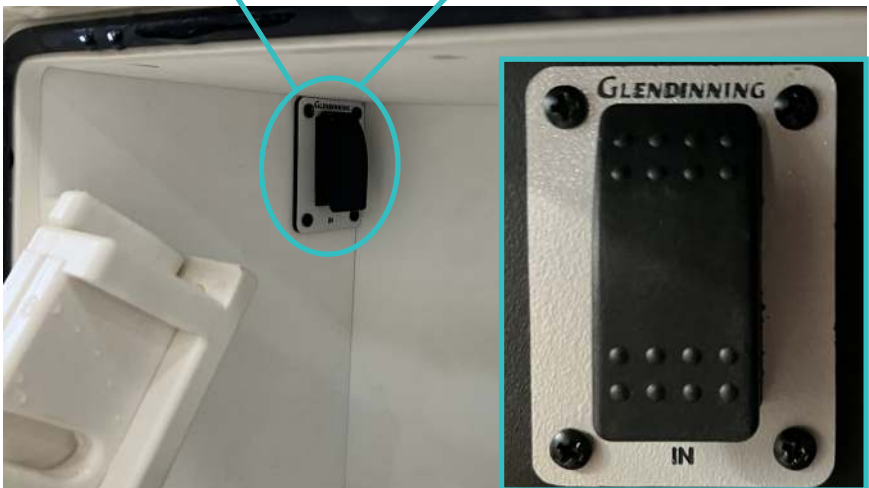

Button location

ELCI

The ELCI breaker can be found in the port-side tub for the convertible transom seat, behind an access panel within the wall of the storage tub. For the UltraLounge, it is behind a cover panel with a pull-strap. See pictures for more detail.



ELCI breaker

For the ELCI itself, shown in the top-right, the breaker switch is on the right-hand side. When in the ON position, test the breaker by pressing the white button. If the switch flips to the OFF position, it is working as intended. If the switch remains ON and no change occurs, please contact your dealer or our Regal Customer Service team.



ELCI - Convertible transom



ELCI - UltraLounge

Batteries

Regardless of electrical package, the LX43 will always come with 12v DC AGM batteries for the engines, house, and electronics, and a 24v DC battery for all bow equipment.

One battery is assigned per engine to be used as starters. They are located in the cabin flooring. The dedicated bow battery is located in the forward-most V-berth storage compartment. Finally, the house and electronics batteries are located in the mid-berth on the port side, hidden by the cabinetry.



Engine batteries

Engine Batteries

Depending on the selected propulsion package, each engine will have a dedicated battery to start the engines. They can be found in the flooring under a cover hatch between both berths.



Engine batteries location

Bow Battery and Bow Thruster

The battery previously mentioned dedicated to the windlass anchor and bow thruster is found in the forward-most V-berth compartment, as shown in the picture on the previous page (“Bow equipment compartment”). To access, grab the backrest cushion from the bottom and pivot upwards, then slide forward. Remove the optional filler cushion if included and the two seat cushions to reveal a white cover panel.

It is important to note that the battery is 24v, as the windlass and bow thruster are 24v components.



Bow battery and bow thruster motor



Bow battery access

House and Electronics

Batteries for the house and electronics appliances are located in the mid-berth on the port-side, hidden by the cabinetry. To access, push upwards on the top panel's bottom lip to pop it out of the clasps.



House and electronics access locations



Panel removed



House and electronics batteries

Fuses

There are three types of DC fuses on the boat: Midi, ATC, and Class T. Understanding fuses is important in order to replace them if necessary.

Midi fuses are small rectangular fuses with teeth protruding from each end and circles punched into the teeth for connections. The amperage rating is displayed on the center body of each fuse.

Typical MIDI Fuse



ATCs are blade type fuses. Both connector teeth protrude from the fuse body on the same side. ATC fuses are designed for lower draw electrical components. Both ATC and Midi fuses have clear bodies designed to easily identify a blown fuse.

When a fuse blows, the wiring in the center of the fuse that connects the teeth is broken.

Typical ATC Fuse



Class T fuses have a central, cylindrical body and two teeth protruding from either end. They are used in the LivePower system, the bow thruster, and to protect some batteries.

Typical Class T Fuse



Breakers

While most breakers are digital and operated using the DSS, manual breakers are also present on the LX43. Access these breakers from the “12v Helm Breaker Panel”, the “Battery Management Board”, and the “AC Main Distribution Panel”.

12v Helm Breaker Panel

The 12v Helm Breaker Panel provides circuit protection for all electrical components controlled at the helm, including the plotters, VHF radio, and trim tabs.

The panel is located on the starboard side of the helm underneath the steering wheel. When a breaker trips, a button on the panel pops out. To reset the breaker, push the button back in until it clicks.

The parallel button manually links all 12v DC batteries (engine, house, and electronics). This should be reserved for emergencies only.



Note: Layouts may vary.

Battery Management Box - DC Breaker Panel

The DC Breaker Panel is part of the battery management box and protects DC components. The battery management box is on the bulkhead of the Lazarette storage compartment, forward of the Seakeeper.

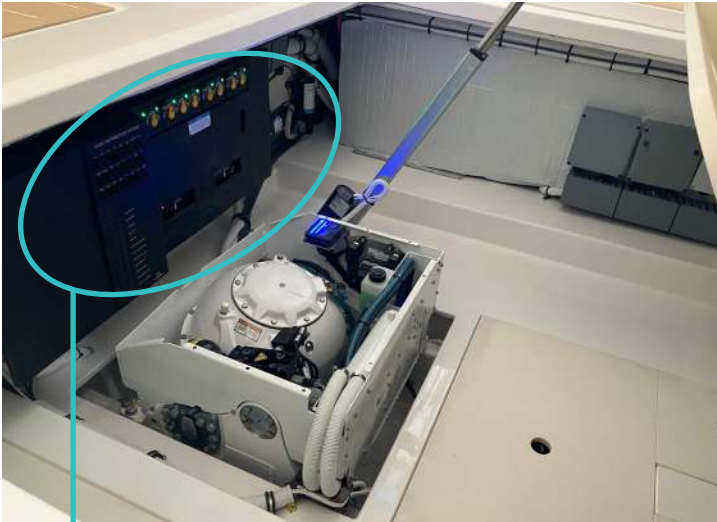

Note: Layouts may vary.

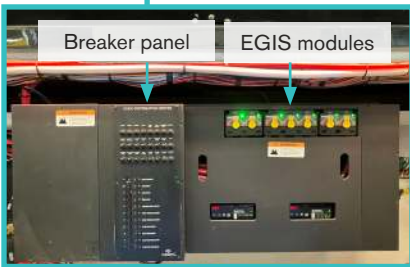

Battery management box

When a breaker on the DC panel trips, a switch on the panel will flip off. To reset the breaker, flip the switch back on.

AC Main Distribution Panel (MDP)

The AC Main Distribution Panel, or MDP, protects all high voltage alternating current components. The MDP controls the power flow from the power source and protects the air conditioning, water heater, cooking and entertainment appliances, and more. It contains all physical AC breakers and is behind the port side flip down seating in the V-berth.



Port side flip down seat



Port side seat opened

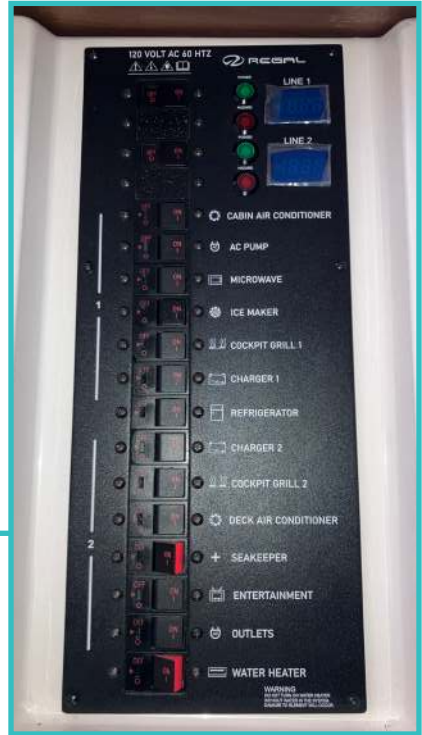

Note: Layouts may vary.

GFCI

The Ground Fault Circuit Interrupter, or GFCI, operates like the ELCI and is used to protect the boat from deadly ground leaks. While the ELCI governs AC power flowing through the whole system from the shore, the GFCI governs all the AC outlets on the boat.

If the GFCI detects a ground leak from any outlet on the boat, it will trip and cut power flowing to all the outlets.

If either the GFCI or ELCI trips repeatedly, have the boat serviced by your Regal dealer immediately and do not use the vessel until the leak is fixed.

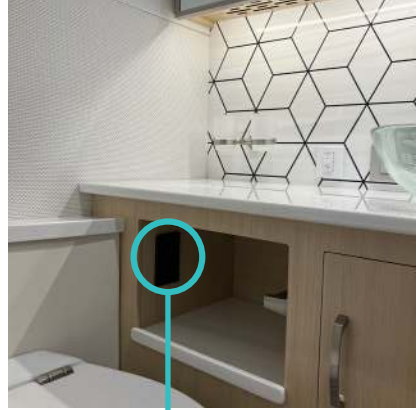

Reset the GFCI from the outlet in the head for any deck outlets or the outlet in the V-berth starboard cabinet for any cabin outlets. When tripped, the top button on the outlet will pop out. Press it in until it clicks to reset the breaker.

EGIS Modules



The EGIS battery management system uses both Remote Battery Switches, RBSs, and Voltage Sensitive Relays, VSRs, to automatically connect the batteries in parallel whenever sufficient voltage is present. By connecting the batteries, the system can charge multiple batteries at the same time.

The battery activation panel also has a “Parallel” button that connects the batteries in parallel. For newer models, this may be located on the 12 Volt Helm Breaker Panel. However, Regal insists on relying on the EGIS system, except in rare emergency situations, to avoid running out of power.

The EGIS system also disconnects the engine batteries as the voltage level drops to ensure that you are not left stranded on the water.

When the boat leaves the Regal factory, all switches and relays are set to “Auto.”

Regal insists on leaving the switches on auto to avoid running out of battery power and being unable to start the engines. However, in an emergency it may be necessary to manually connect or disconnect the batteries.

To connect or disconnect the batteries from the EGIS, turn the switches on the unit to either “OFF” or “ON.” Off will turn the batteries off completely. On will connect the batteries. Do not forget to disconnect the batteries or you will run out of power and be left stranded.

Only manually connect batteries in emergency situations.

NOTICE

THE BATTERY PARALLEL FEATURES ON THIS VESSEL ARE INTENDED FOR EMERGENCY INTERMITTENT USE ONLY!
WHEN A PARALLEL FEATURE IS REQUIRED IT MAY INDICATE A SERVICE BATTERY IS NEAR THE END OF ITS USEFUL SERVICE LIFE.

Garmin Chartplotters

The onboard Garmin displays or chartplotters are the central control system for the vessel. The plotters are touch screens that function like tablets.



Note: Layouts may vary.

There are 4 Garmin displays on the boat: three displays at the helm, one above the cockpit grills and sink, and one on the port cabin wall. The displays are powered by the DC battery bank. To turn on the chartplotters, make sure the DC battery bank is on (see “Battery Activation Panel”, page 87 & 138). The plotters should turn on automatically once the batteries are on; if they do not, tap the power icon in the lower right hand corner of the display.

The Garmin chartplotters are used for information and control over the entire vessel. To access pages within the helm chartplotters, navigate to the home screen (shown on the next page). Some icons will come preloaded on the home screen. Use these icons to access their corresponding pages. Garmin chartplotters are customizable. Icons and data can be removed, added, or rearranged to suit your needs. To customize an icon, hold the icon until a drop down menu appears.

To access the additional pages, tap the “Layouts” icon at the bottom center of the screen (white bar). This will bring up a scrollable row of icons. To scroll through the bottom row, slide your finger along the screen.



Note: Layouts may vary.

To access pages not preprogrammed to the home screen, tap on any layouts such as “Charts”, “Radar”, “Sonar”, “Gauges”, and more from the horizontal scroll.

For more specific Garmin operational instructions, refer to your Garmin owner's manual included in your welcome packet.

Regal programs and organizes chartplotters based on years of boating experience. Regal recommends utilizing the Garmin system as it comes delivered from the factory. Customization is best done once you become familiar with your preferences after embarking a few times.

Seakeeper

The Seakeeper is a gyroscope that counteracts boat roll and stabilizes the vessel on the water. It is controlled from its dedicated page within the chartplotters. To navigate to the Seakeeper page, tap the Seakeeper icon on the home screen. Once on the page, turn the Seakeeper on by tapping the gray power icon (ensure the manifold valve is open, below it is shown as closed). The button will turn blue indicating the Seakeeper is on. This can also be done by tapping the boat icon in the top left of the DSS home page to bring up a small menu of quick actions.

Monitor Seakeeper performance and boat roll using the roll angle gauge on the Seakeeper page. Refer to the manufacturer owner's manual for specific operating instructions.



Seakeeper location



Seakeeper control page



Seakeeper DSS icon



Raw water manifold

Digital Switching System (DSS)

The Digital Switching System controls most electrical devices on the LX43. Where there were once rows of physical switches, there now are convenient and minimal touchscreen displays.



Note: Layouts may vary.

Navigating the DSS

When the vessel leaves the Regal factory, the DSS is set as one of the helm plotters' launch screen. To access the system, turn on the boat and power up the displays. All chartplotters will load their respective pages; the hardtop chartplotter will load the hardtop page, the cabin chartplotter will load only the cabin page.

If the DSS does not appear or you would like to navigate there from another page on the display, tap the digital switching icon indicated by the Regal Boats logo.

Bilge Pumps

There are two bilge pump indicator lights on the bottom left corner. When the pumps activate automatically, the lights will be red. Tap the icon to manually run the pumps temporarily. When running manually, the light will be blue for 60 seconds. Hold the icon to bypass and run the pumps continually. When bypassed, the light will be green. Hold the icon again to turn the pump off.

Engine Flush

Press the “Engine Flush” icon to flush the engines with freshwater from the freshwater tank or shore water for 10 minutes. This is only for Mercury engines.

Freshwater Activation

Tap the “Fresh Water” icon to activate the freshwater pump. The indicator will be solid blue when activated and flashing yellow/blue when running.

Battery Information

Tap the battery icon in the top left corner to open the voltage indicators for all DC batteries (not including the PowerBank option). The voltage indicator(s) will change from green to yellow to red based on each battery’s voltage. The links between the batteries identify if it is paralleled or not. If the link is green, the two batteries are linked in parallel. The ACC battery is the dedicated bow battery.



Voltage indicators



Dedicated A/C page

Engine Blowers

Tap the “Blowers” icon to run the bilge blowers.

Seakeeper

The boat icon is a Seakeeper auto-stabilization icon. Tap it to open a small menu of quick actions to activate the Seakeeper stabilization system instead of navigating back to the dedicated Seakeeper page.

Air Conditioning (A/C) Control

If the air conditioning is activated, there will be a temperature reading at the top center edge. Tap it to open a quick control menu shown below.



A/C quick controls

The port side controls the vents on the refreshment island and companion seating. The starboard vents are those at the dash and aft-most seating in the main cockpit. The air flow can be controlled with the arrows to the left of the temperature reading and the temperature itself can be set with the arrows to the right. Tapping the white home button on the far left will close the menu. Tapping the central temperature reading again will open a dedicated page with larger icons (shown to the left). Tap the 3 white lines in the bottom right to return.

Tapping the “Mode” icon will toggle the air conditioning system between heating and cooling.

Horn

Tap the “Horn” icon to honk the horn. The button near the steering wheel shown to the right can also be used.

Windshield Wipers

Tap the “Wipers” icon to open the wiper control pop up. The leftmost icon activates the port wiper only. The two middle buttons spray freshwater onto the windshield for the respective sides. The fourth icon activates the starboard wiper. Lastly, tap the “OFF” icon to deactivate or adjust wiper speed using the “+” or “-” icons.

Additionally, use the wiper button shown above to toggle the wiper for one passthrough. It will not run continuously.

Bow Thruster Cutoff

The red “STOP” bow thruster icon in the top right corner of the DSS home page cuts off the current to the bow thruster, instantly deactivating it. This should be reserved in the event of a runaway bow thruster.



Wiper controls



Bow thruster emergency stop

Deck

There are 3 main pages within the DSS: the Hardtop, Deck, and Cabin pages.

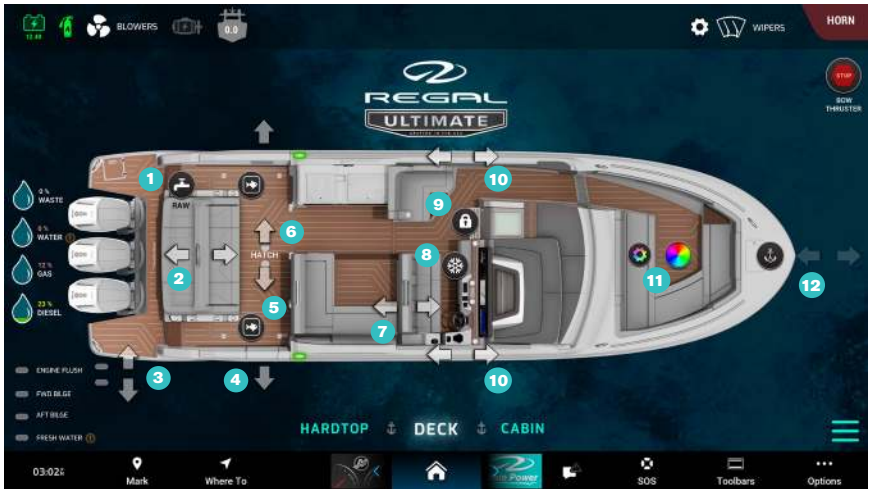

- | | |
|----------------------------------|-----------------------------------|
| 1 - Raw Water Activation | 7 - Helm Seat Forward/Aft Control |
| 2 - Baitwell/UltraLounge Control | 8 - Chiller Tub Activation |
| 3 - PowerPlatform | 9 - Cabin Door Lock |
| 4 - Terrace Door Control | 10 - Side Window Control |
| 5 - Fishbox Pump-outs | 11 - RGBW Lighting |
| 6 - Lazarette Compartment Hatch | 12 - Anchor Windlass Control |

Control all on-deck electrical devices from the “Deck” page. Tapping a device icon on the boat map illuminates the icon, indicating the device has been activated.

Baitwells

To activate the baitwells, press the fish hook icon. More icons will appear. Tap the pump icons to fill the baitwells and tap the light icon to turn on the baitwell lights. To drain the baitwells, first turn the pumps off. Then, open the drain valves.



Baitwell controls



UltraLounge controls

UltraLounge

For the UltraLounge option, tap the corresponding arrows to move the structure forward and aft.

⚠ CAUTION

AVOID COLLISION BETWEEN THE **ULTRALOUNGE AND LAZARETTE HATCH!** ENSURE THE ULTRALOUNGE IS POSITIONED AS **AFT** AS POSSIBLE.

⚠ CAUTION

AVOID COLLISION BETWEEN THE **ULTRALOUNGE AND ENGINES** WHEN TRIMMING ENGINES OUT OF WATER! ENSURE THE ULTRALOUNGE IS POSITIONED AS **FORWARD** AS POSSIBLE.

Lazarette Hatch

To open the Lazarette hatch, tap the up arrow. Hold the down arrow to close the hatch.

PowerPlatform

To deploy the PowerPlatform, tap the bottom arrow. The light icons on the DSS will flash yellow when being deployed or retracted. The light will be amber if an amperage spike is detected while deployed. If there are any issues with the platform, the light will turn red.

Fishboxes

To drain the fishboxes, press the fish icons to activate the macerator pumps for 4 minutes. Do not activate the pumps without running water through them.

Terrace Doors

Tap the corresponding Terrace Doors buttons to lower or raise them. The light indicator is green when the doors are up and the locking pin is engaged. A yellow light indicates they are deployed.

Fresh/Raw Water Activation

Tap the “FRESHWATER” icon in the bottom left and “RAW” faucet icon to activate the fresh and raw water systems. Once turned on, the icon will be solid blue. When running, the icon will flash yellow/blue. When the freshwater tank gets below 10%, a low water alert will appear next to the freshwater icon and the icon will lock. To bypass the lock, hold the icon for two seconds.

Manual Bypass

Some other icons can be bypassed by holding the icon for two seconds. When operating in a manual bypass, the icons will turn green. When operating normally, the icons will turn blue. Holding a bypassed icon again will revert to its normal operation. Use caution when bypassing components that require flowing water to operate. This may damage the pumps. Refer to the backend menu (page 169) for information on icons that can be bypassed.

Chiller Tub

Tap the snowflake icon to activate the chiller tub on the left side of the helm dash. Make sure the breaker at the MDP is turned on.



Terrace Doors deployed

Cabin Door

Tap the lock icon to open the lock combination pop-up (see page 115). The code is 0123.

Side Window Control

To open the side windows, tap the corresponding port/starboard arrow pointing aft (left) on the screen. To close, hold the arrow pointing forward (right) on the screen. This is shown below.



Side window controls

Helm Seat Forward/Aft Control

Hold the respective button to move the entire helm seat forward or aft.



Helm seat controls

RGBW Lighting

Tapping the settings wheel brings up a control panel for RGBW lighting only (shown below). Tapping the color wheel itself simply toggles the lights on and off.



RGBW lighting menu

Windlass Anchor

Finally, tap the anchor icon to pull up the windlass controls. The arrow pointing outboard in the image (right) deploys the anchor while the other (pointing inboard/left) retracts.

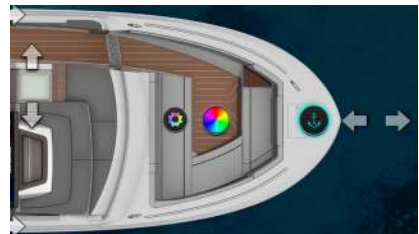

Windlass anchor controls

Hardtop



1 - Spreaders Lighting

2 - PowerShade Control

3 - Navigation Lights

4 - Cockpit TV Control

5 - Overhead Lighting Control

6 - Sunroof Control

7 - Lightbar

8 - Bow Access Window

This “Hardtop” page controls all hardtop equipment.

Tap the “Spreaders” icon to turn on the lights on the aft face of the hardtop.

Tap the PowerShade arrows to extend or retract the power shade.

Tap the “NAV Lights” icon once to turn on the running navigation lights. Tap a second time to turn on the anchor light. A third tap will turn off the lights.

Tap the “Cockpit TV” arrows to raise and lower the cockpit TV.

The “Overhead” lighting slider controls the intensity of the cockpit lighting.

Tap the “Lightbar” icon to turn on the light bar.

Tap the corresponding arrow to open or close the window pane that allows access to the bow area.

Cabin



The “Cabin” page controls all the lights in the cabin and the Lazarette compartment. It can also raise and lower the Lazarette compartment hatch.

Backend Menu



Tapping the three lines in the lower right hand corner of the screen will open the back end menu. The back end menu controls all DSS equipment from one screen.

Column 1 - Lighting

The left most column contains all basic (non-RGBW) lighting on the boat.

Column 2 - RGBW

The second column from the left contains all RGBW lighting on the boat.

Column 3 - Actuators/Motors

The middle column contains all actuators and motors. Some actuators may require holding the icon to activate. Follow the instructions in yellow below each icon label.

Column 4 - Fluids

The fourth column (second from the right) contains all fluid controls including pumps, macerator, and optional ice maker. Follow the operational instructions in yellow below each icon label.

Column 5 - Power Saver

Turn electrical equipment on and off with the right most column. When turned off, electrical equipment will not receive power and be inoperable.

Empirbus

An Empirbus module is a digital distribution module that receives commands from the Digital Switching System in each plotter and controls devices accordingly. Tapping an icon in the Digital Switching System sends a signal from the chartplotter to an Empirbus module that reads the signal and powers the appropriate device.

Note: Layouts may vary.



1 - Power Supply

2 - NEMA 2000 Port

3 - Breaker Control Buttons

4 - Channel Indicator Lights

Each channel on the Empirbus has an LED light that indicates if the specific channel is active.

Some channels are always powered; others are powered only once they receive a signal from the DSS.

If the channel is active, the light will be green. If the breaker for the channel is tripped the light will be red. If there is no power flowing through the channel, the light will be off.

Breakers are reset using the “Breaker Reset” page within the DSS (see next page). In the unlikely event that the chartplotters go down, reset the breakers and activate DSS controlled devices on the Empirbus modules themselves. Channel breakers are controlled using the buttons on the front of the module.

First, use the arrow buttons on the left side of the unit to navigate through the channels. Pressing the arrow buttons will turn off all the channel lights except for the selected channel. Use the ‘left’ and ‘right’ arrows to navigate to the desired channel. The lights will turn on and off as you cycle through channels. Stop when the light for the correct channel is illuminated.

After accessing the channel, use the “Man On/Man Off” button to turn the channel on or off. After manual operation is complete, press the “Reset/Auto” button to return the channel to automatic function.

To reset the channel’s breaker, press the “Reset/Auto” button. Contact your dealer for a channel list of all Empirbus modules.

Garmin WDUv2

The Web Display Unit or WDU is the translator for the digital switching system and is powered by the NMEA 2000 network (see below).

Tapping an icon in the DSS prompts the WDU to receive, interpret, and transmit a signal to the Empirbus modules via the NMEA network.

NMEA 2000

NMEA 2000 is a communication network system between electronic devices. The NMEA backbone is the main hub of the system; some devices must be connected to a NMEA backbone to communicate to other devices from different manufacturers that otherwise wouldn’t be compatible. The NMEA network is spread throughout the boat and sends control commands to applicable electronic devices.

The NMEA network also makes items visible on the plotters and if an icon is missing or a system is no longer accessible from the plotters, there may be an issue with the NMEA network. Have the boat serviced by your dealer if you believe there are issues with the NMEA network.

⚠ CAUTION

DO NOT SIT, STAND ON, OR TRY TO IMPEDE ACTUATOR EQUIPMENT. DOING SO MAY DAMAGE THE ACTUATOR.

⚠ WARNING

PREVENT POSSIBLE INJURY!
BEFORE OPENING OR CLOSING ANY ACTUATOR CONTROLLED SYSTEM ENSURE THAT ALL PERSONNEL ARE CLEAR FROM THE ACTUATOR OPERATION AREA!

Breaker Reset

The 'Breaker Reset' page will display any tripped breakers in the system. All breakers in the digital switching system are digital and can be reset by tapping the reset button when it appears on the 'Breaker Reset' page. An alert will show if a breaker trips.

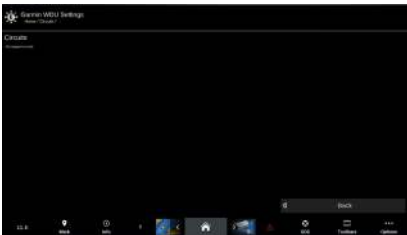

Breakers trip when more power is sent through the breaker than the breaker can handle. Digital breakers can be easier to trip than physical breakers. Impeding the motion of an actuator is one way to trip a breaker.

Trouble Shooting

If the DSS needs to be reset, turn the boat on and off using the battery activation panel.

Follow these steps for simple troubleshooting solutions to potential problems.

- **Screen is dark and won't come on.**
 1. Screen may be asleep. Tap the screen.
 2. Screen may be off. Turn the screen on.
 3. Cycle power by turning vessel on and off.

- **Screen is frozen (spinning circle).**
 1. Cycle power to reset.

- **Tap an icon, but nothing happens.**
 1. Check the digital breaker. Make sure it is not tripped.
 2. Check applicable equipment: ensure light bulbs are new, actuators are working properly, and electrical connections are secured.

3. Cycle power to reset.
While digital breakers are more sensitive than physical breakers, if a breaker is tripped often it may indicate an issue with the circuitry and you should have the vessel serviced by your dealer.

If problems persist after trouble shooting, have your dealer service the vessel.

Your dealer has received factory training; employ their services to solve advanced technical issues or any issues you are not sure how to solve.



Fluids - Freshwater

The LX43 carries a freshwater system to provide clean water for amenities such as the head, faucets, washdowns, etc.

Freshwater Tank

The 71 gallon freshwater tank is the main source of freshwater that feeds the onboard head, shower, faucets, and washdown. The tank can be accessed near the aft wall of the mid-berth area. First, remove the backrest/filler cushion, followed by the accent cushion on the lower edge. Once both are removed, the fresh water tank will be visible through a small access.

Before embarking, check fresh water levels in the DSS (see “Digital Switching System” on page 160). There is a droplet icon labeled “WATER” on the left side of the screen. Keep an eye on fresh water levels while embarked to avoid running out of potable water.



Backrest cushion to be removed



Bottom panel to be removed

Filling

Fill the tank from the freshwater deck fill labeled “Water” on the port side gunwale just past the Terrace Doors. Unscrew the cap, thread one end of the freshwater hose to the water source and insert the other into the fill. Turn the water source on and fill the tank until the freshwater icon in the DSS reads full. Turn the water off, disconnect the hose, and replace the fill cap.

A freshwater pump in the Lazarette compartment on the starboard side of the Battery Management Box then distributes the water around the vessel. Check the strainer next to the freshwater pump before activating the system. Remove any debris.

After filling the tank, tap the “FRESH” icon on the “DECK” page of the DSS to activate the freshwater system (page 160). The freshwater system must be activated before using the shower, head, and faucets. Open a faucet to purge air from the system and check that there is water flowing from the tap.

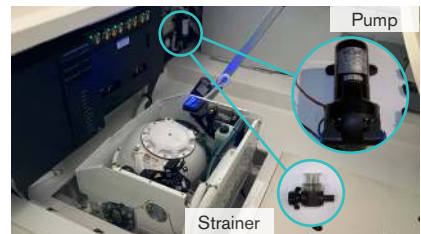

Pump access



Shore Water

The freshwater system can also run from an onshore water source when docked. To connect to an onshore source, remove the cap from the shore water inlet on the aft face of the convertible transom seat or UltraLounge toward the lower starboard side.





Shore water connector

Connect one side of a freshwater hose to the threaded side of the connector. Next, insert the connector into the shore water inlet. Finally, thread the other end of the hose to the onshore water source.

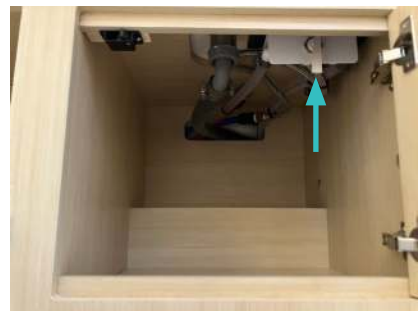
The shore water shutoff valve is under the sink in the head. When the valve handle is turned to the left (open), water will fill the onboard freshwater tank. When the valve handle is turned downwards (closed), the system will pressurize and pull water directly from the onshore source instead of the tank. Turn the onshore water supply on and check the hose and connections for leaks.



Shore water shutoff valve

NOTICE	
	Open valve to fill freshwater tank from shore water inlet.
	Close valve when tank is full.

The boat's freshwater system is designed for **non-potable water use only** and is not suitable for drinking or cooking. Please use bottled or treated water for all human consumption.

Sanitizing the freshwater system remains a priority to prevent bacterial growth and maintain water quality for showering and washing dishes. For more detail on the sanitization process, please refer to page 183.

Head

The onboard head is a vacuum style marine toilet designed to use minimal water. The head runs on 12v DC power and has a dedicated breaker on the Battery Management Box. The head pulls water from the onboard freshwater tank. If connected to an external water source, the head will still draw its water from the onboard freshwater tank.

Operate the head via the wall control switches on the back wall of the sink counter. Press and hold the “ADD WATER” side of the switch to add water to the bowl. Release when the water reaches the desired level. Press the “FLUSH” side of the switch to empty the bowl into the wastewater tank. The system will automatically replace a small amount of water in the bottom of the bowl to eliminate potential odors. It is not necessary to fill the bowl with water to use the head. Keep an eye on water levels to avoid running out of freshwater while underway.

The general head control panel is next to the toilet switches. This panel controls the lights in the bathroom and the exhaust fan vent. The head exhaust vent is located on the starboard wall of the shower, near the top edge.

Do not flush any foreign materials – paper towels, moist towelettes, hygiene products, or garbage – down the toilet. Only flush appropriate waste and RV or marine specific toilet tissue to avoid damaging the head or the waste system. RV and marine toilet tissue can be purchased online, in home-improvement stores, or boating supply stores.



Head controls

If the waste holding tank is full, the head's flush function will lock. The waste tank's sensors are positioned just below the tank's capacity, thus it is sometimes possible to fill the tank past "full."

Holding the flush button for eight seconds will override the lock and flush the head. Only override the lock when there is additional room in the tank and do not override the lock more than twice before emptying the tank to avoid overflow or damage to the waste management system. Regal is not responsible for damage to equipment that may result from waste overflow due to overriding head lockout. Improper system use is not included in your warranty.

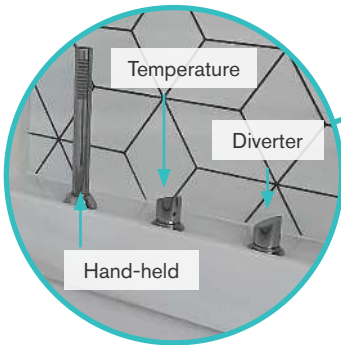

Shower

The shower has both a waterfall and hand held shower head. There are two shower handles. The right handle controls the flow of water to the shower heads. When it is turned to the left, water will flow from the waterfall shower head. When it is turned to the right, water will flow from the hand-held shower head. The left handle controls the water temperature. Turn the handle right for hot water and left for cold.



Secure the shower door before embarking. The spring-loaded latch lock is located at the top of the glass door.

The shower pulls water from the freshwater tank. When the vessel is connected to an external freshwater source and pressurized, the shower will bypass the freshwater tank and pull directly from the external source.

Shower Box

Water drains through the floor grate and down into the shower box (see below). The shower box is a collection and distribution point for waste water used by the shower, head sink, and A/C system. It is located below the floor in the mid-berth. To access the shower box, pull back the carpet and open the hatch. Turn the center cover on the top counter-clockwise to access the inside of the box.

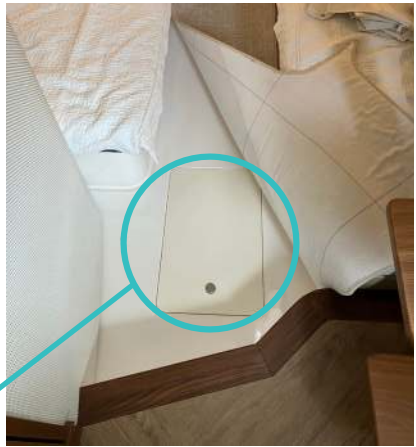

Shower box location and access



Shower box

A gulper pump in the engine compartment then evacuates the water overboard or into the wastewater tank if the boat has the optional gray water system.

Clean the shower box and pump periodically to prevent clogging.

Water Heater

The onboard water heater operates to a max temperature of 125 °F. A cold water line feeds water through the tank where it is heated by an element. The hot water line then carries the water out of the heater, to a distribution manifold, and then to the shower and faucets. The water heater holds 5.3 gallons; do not expect hot water to last as long as in your home. Take shorter showers to conserve hot water and onboard freshwater in general.

The water heater is in a compartment forward of the V-berth. Fold up and push in the V-berth seat back and push in the V-berth seat back and remove the panel to access.

Waste Tank

The waste tank holds 26 gallons of wastewater. It is aft of the cabin and separated by a fume barrier. It has a pump out fitting labeled “WASTE” in the port gunwale just forward of the Terrace Door. Marinas and other docking facilities often have onshore waste pumps for emptying the waste tank. Always keep an eye on accumulating waste levels and plan to pump out in advance to avoid overfilling the tank. Always check



Water heater

waste tank levels before embarking. Waste levels will be displayed on the left side of the DSS (see “Digital Switching System” on page 160).

To empty the waste tank:

1. Remove the cap from the gunwale “WASTE” pump out fitting.
2. Put on any personal protection equipment like latex gloves to avoid disease and waste contamination.
3. Remove the pump hose from the onshore pump system and lay the coil on the deck. Check for kinks or potential blockages before attaching the pump to the on deck fitting.
4. Make sure the nozzle valve on the waste pump is in the off position—perpendicular to the hose nozzle.
5. Turn the pump on.
6. Put the nozzle into the on-deck fitting. Turn the nozzle to tighten until you cannot tighten any further to ensure that there is an airtight seal between the nozzle and the fitting.
7. Turn the nozzle valve on – parallel to the hose nozzle. Maintain a seal during the entire pumping process.
8. The glass on the nozzle should become cloudy as waste is pumped through the hose. The glass will clear as most waste is pumped out of the tank. Continue pumping until you are confident no more waste is flowing from the tank.
9. After the first pump out, flush water down the head, then return to the pump and pump out the remaining waste.
10. When no more liquid flows from the tank, turn the valve off. Before removing the nozzle from the fitting, tilt the nozzle slightly and allow any liquid remaining in the nozzle to drip back down into the tank.

11. Once all the remaining liquid has dripped out of the nozzle, submerge the nozzle in a bucket of water and open the valve to clean the hose and flush any remaining waste down into the pump. Once the bucket is empty and the pump has drained all the water, let the pump run dry for a few seconds and then turn the valve off.
12. Turn the pump off and replace the hose.
13. Use a garden hose to rinse any liquid in the fitting back down in the waste tank and replace the waste cap on deck before embarking.



Waste pump-out

Overboard Discharge

In the event the overboard discharge option was selected, a macerator comes with the waste tank. There are numerous federal and international regulations governing overboard discharge of waste on the high seas and in coastal waters. Some of these regulations govern the size of discharged waste particulates. The macerator breaks down the onboard waste to appropriate size for legal discharge when on the high seas.

To discharge the waste tank, first open the discharge seacock located in the Lazarette Compartment (see the following page). Next, activate the macerator from the DSS in the chartplotters (see “Digital Switching System” on page 160) to pull the contents from the waste tank and through the discharge seacock.

Regal waste management devices do not come with waste treatment chemicals. It is illegal to dump any untreated waste in any body of water within any part of the United States and up to three miles off the coast. Do not dump untreated waste overboard in any American waters under any circumstance as such action could impose heavy fines and jail time. Refer to the General Vessel manual and the

United States Coast Guard for more information on environmental waste regulations. Regal Marine Industries Inc. does not accept any liability or responsibility for the consequences of illegally dumping untreated waste.



Overboard discharge location

Sanitizing and Winterization

Regal recommends sanitizing the water system at least once a year.

First, flush the entire freshwater system by running the faucets and shower until the entire system is empty, including the water heater. Discharge any waste water that has accumulated in the waste tank. Fill the tank with a 100 parts per million chlorine solution and allow the solution to stand for at least an hour. Drain the chlorine solution and flush the system with fresh water. Allow the fluid to drain and then refill the tank.

Proper winterization depends on expected temperature levels over the time the boat will be stored. Due to variation in proper winterization procedures, Regal insists on contacting your dealer to winterize the vessel. Improper winterization may result in damage to the vessel and is not included in your warranty.

Washdowns

Washdowns are found throughout the deck. One can be found in the bow anchor locker; two more are found on the aft face of the refreshment island; a final washdown is found near the transom. Twist the handles to use the refreshment island washdowns.

To use the transom washdown, simply twist from the end. There is a notch that allows temperature control.

Don't forget to tap the "FRESH" icon in the bottom left corner of the DSS page. To use the raw water washdown, press the "RAW" faucet icon near the transom, also on the DSS "Deck" page.

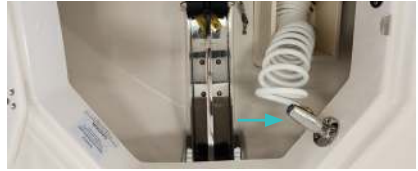

Anchor locker freshwater washdown



Refreshment island washdowns



Transom washdown - UltraLounge

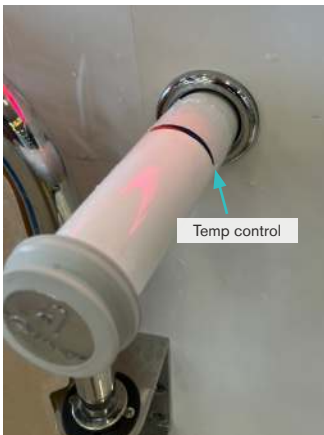

Transom washdown



Transom washdown - Convertible transom

Fluids - Raw Water

Raw seawater is generally used for cooling components. Raw seawater enters the boat through 2 dedicated seacocks in the Lazarette Compartment.

Seacocks

There are two seacocks that allow water into the vessel. The starboard side seacock with the larger stainer feeds the central raw water manifold in the middle of the Lazarette compartment beneath the removable floor panel just aft of the seakeeper. The port seacock is the dedicated generator raw water feed.

The generator has a water separator with a dry and wet exhaust, which both output by thru-hull. Each component that uses raw water from

the manifold outputs by thru-hull on the transom and does not utilize an output seacock.

This central raw water manifold feeds the Seakeeper, A/C pump, baitwell pumps, chiller compressors, raw water washdown, and the optional on board ice maker. Make sure the respective seacock is open before operating the corresponding equipment. Before embarking, clear the manifold strainer filter of any debris.

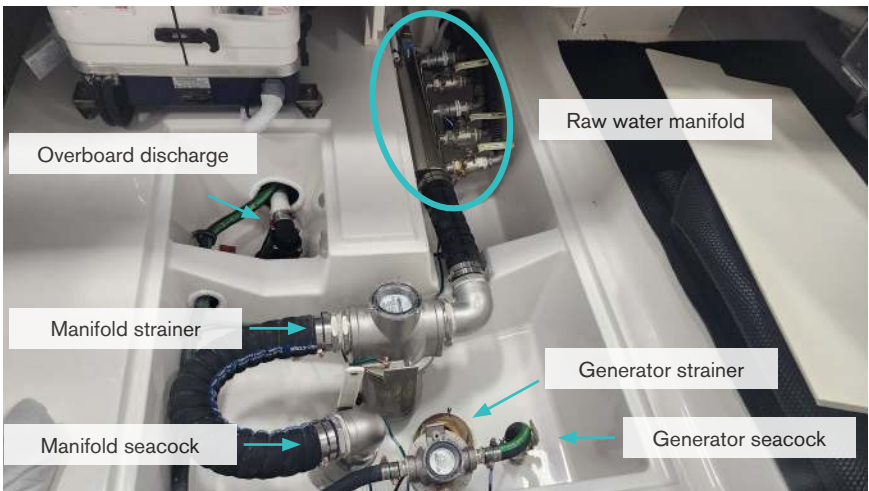

First, close the seacock to stop the flow of water. To remove the strainer basket, turn the plastic cap counterclockwise and remove the cap and the o-ring inside the cap. Pull the basket out, dump out any debris and rinse clean.

Sediment may have accumulated in the bottom of the strainer. To clear sediment, remove the plug on the underside and allow the strainer to drain completely.

Replace the plug, basket, and cap once the unit is clear of debris.



Seacock strainer



Raw water manifold

Raw Water Manifold

The raw water manifold always feeds the air conditioning, raw water washdown, and seakeeper stabilization system. Depending on customization options, it may also feed the baitwells.

Make sure the respective seacock is open before operating the corresponding equipment. Before embarking, clear the manifold seacock filter of any debris. Always verify the handle on the manifold is open (as shown in the image to the left, except the seakeeper handle) before operating any components.

Seakeeper

Turn the Seakeeper breaker on at the MDP and verify that the seakeeper handle on the water manifold is open (the image below shows the closed position).

Activate the Seakeeper from its dedicated page within the chartplotters. Tap the gray power icon in the top right corner to turn it on. Alternatively, tap the boat roll icon within the DSS Deck page.

It will take between 20 and 40 minutes for the flywheel to get up to speed. A boat roll icon will appear below the power icon once the flywheel is up to speed. Tap the icon to activate stabilization.

Monitor Seakeeper performance and boat roll using the roll angle gauge on the Seakeeper page.

Refer to the manufacturer owner's manual for specific operating instructions.



Seakeeper location



Seakeeper control page



Seakeeper DSS icon



Raw water manifold

Baitwells

There are two 30-gallon pressurized baitwells in the center of the convertible transom seat. The baitwells continuously pump water to maintain pressure against the sealed lids. Make sure the fill valve is open and the two drain valves are closed in each baitwell before operating (see image).



Baitwell details

Water will continuously overflow through a cutout in the lid gasket at the outboard aft corner of the lid. Adjusting the top drain changes the amount of water that overflows the gasket. Twist the drain to adjust.

To fill the baitwells, tap the hook icon on the “Deck” page of the DSS. A pop up will appear. Tap the pump icons to fill the baitwells and tap the light icons to turn on the baitwell lights. To drain the baitwells, first turn the pumps off and open the drain valves.



Bilge Pumps

The bilge pumps operate both automatically and manually. Float switches will automatically activate a pump when necessary. To manually activate the bilge pumps from the DSS, use the two icons in the bottom left corner, labeled “FWD Bilge” and “AFT Bilge” (see image on the next page).

The light will be red when activated automatically. Tap the icon to manually run the pumps temporarily. When running manually, the light will be blue for 60 seconds. Hold the icon to bypass and run the pumps continually. When bypassed, the light will be green. Hold the icon again to turn the pump off.

Keep an eye on the bilge pump icons; while some water is expected to accumulate in the bilge, consistent pump activation may indicate a leak somewhere in the boat. If you suspect there is a leak, have the boat serviced by your Regal dealer. There are three bilge pumps on the vessel – two in the Lazarette compartment and one in the cabin. The main pump is set all the way aft in between the two central stringers. The secondary pump is underneath the Seakeeper. The third is in the cabin, underneath the shower box (see page 179).

Before embarking, check the bilge pump outlet for debris and test the bilge pumps by manually activating each pump. Make sure the bilge pump indicator icons illuminate when you activate the pump.

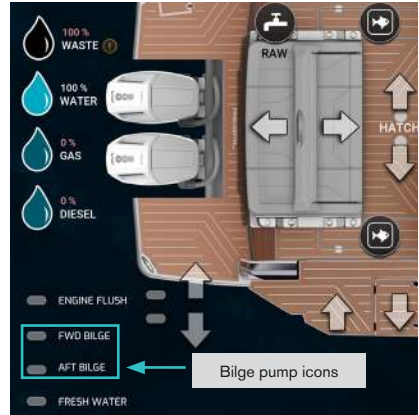

A/C - Air Conditioning

The A/C system is part of the raw water system and uses a pump to draw water from the raw water manifold. The raw water loop through the A/C units discharges through the transom by thru-hull.

To operate, open the respective manifold valve. Next, flip on the “AC PUMP” and other A/C breakers on the MDP. The pump should start automatically, if it does not, activate using either the Garmin display for deck A/C, or the cabin control panel for cabin A/C.

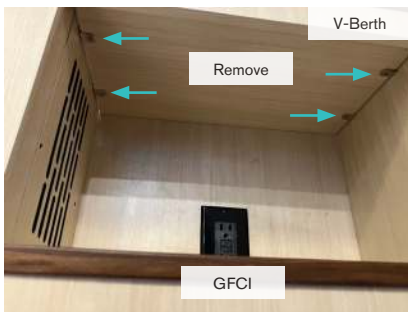

Starting with the photo to the left and continuing on the next page are instructions for how to access each A/C unit, if inspection is necessary. Contact your Regal dealer for proper maintenance.

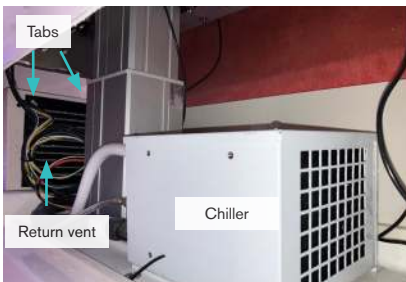
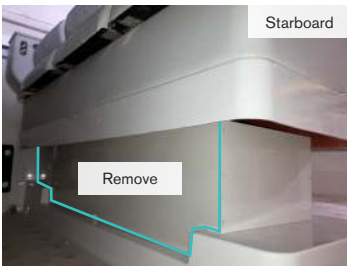

The cabin A/C unit is located behind a cabinet in the v-berth. To access, first remove 4 screws on the bottom face of the horizontal mid-shelf panel. Remove the panel by lifting up and out of the cabinet. Next, remove 4 bolts on the return vent to expose the A/C unit.

The port deck A/C unit is located under the companion seating. To access, first remove the storage drawer on the inboard face of the seating. The tracks are fastened with a bolt and nut inside the drawer. Once the drawer is out, remove the Phillips screws inside the compartment and remove the entire cabinet.

The starboard deck A/C unit is located under the helm seats. To access, raise the helm seats to maximum height and remove the 6 Phillips screws that secure the acrylic panel at the base of the seating structure. Next, rotate both silver tabs on the return vent shown in the final photo on this page.

Never block any vents, especially return vents, as it may cause damage to the A/C units. Refer to the manufacturer owner's manual included in your welcome packet for specific operational instructions.

Safety

The LX43 comes equipped with a fuel vapor detection system and an automatic fire suppression system in the Lazarette compartment, as well as combined CO/smoke alarms within the cabin.

Gasoline Vapor Detection

There is a gas vapor detection indicator light on the ignition panel just below the steering wheel at the helm.

In the unlikely event of a gas vapor leak, the vapor detection system will issue an alarm and the “DANGER” light on the ignition panel will illuminate.

If the vapor alarm goes off, cease operating the vessel immediately, turn off all potential sources of combustion and service the boat with your Regal dealer before operating again.



Gas vapor detector

Automatic Fire Suppression

In the event of a Lazarette compartment fire, the system will automatically discharge the fixed fire extinguisher to put the fire out. The system will also automatically shut down the generator and the blowers. If the extinguisher discharges, immediately turn off the engines, electrical systems, and generators.

There is a “Fire Suppression” indicator light within the DSS (see below). When the system is charged and ready to detect a fire, the light will be green. If the system has detected a fire and is discharged, the light will flash red and an alert message will display on the Garmin chartplotters.



After discharging, the system will shut down and lock the blowers and generator. There are two overrides. The first is in the digital switching system. After discharge the blower icon will be red and an override message will appear next to the icon. Tap the override icon and the red ring will disappear, allowing the blowers to run again.

The other override is on the Fireboy panel underneath the steering wheel. When the system auto-discharges, the panel will flash red and issue an alarm. Press the override button on the panel to shut off the alarm and reactivate access to the generator and blowers. There is also an indicator light on the ignition panel below the steering wheel that will illuminate when the ignition is on and the system is charged and will turn off once the system has discharged.



Fireboy shutdown panel

Manual Fire Suppression

To operate the system manually, access the fire extinguisher pull handle underneath the starboard mezzanine seat, next to the battery activation panel (see below).

Remove the safety pin to release the "FIRE" handle and then pull firmly on the handle to activate the fire extinguisher.

A loud whooshing sound will indicate the extinguishers have successfully deployed.

After a fire, do not attempt to restart the boat. Have it serviced by your Regal dealer before embarking again.



Manual pull handle

NOTICE

FIRE SUPPRESSION SYSTEM SHOULD BE INSPECTED ANNUALLY BY THE MANUFACTURER.



Fixed fire extinguisher

CO/Smoke Detectors

Carbon monoxide, CO, is toxic in any quantity and deadly in high concentrations. The boat comes equipped with two combo CO/Smoke detectors that monitor vapor levels and will sound an alarm when CO or smoke concentration in the cabin reaches levels that are

unsafe. Both detectors are on the starboard side – one on the head wall in the V-berth and one next to the TV in the Mid-berth. Refer to the General Vessel manual for more information about the dangers of CO poisoning and how to avoid potential CO accumulation.

The detectors are battery powered. If functioning properly, a green light on the detector's body will flash every 180 seconds. Refer to the manufacturer owner's manual for detector testing frequency and procedure. If you have any reason to believe the CO detector is not functioning properly, follow the troubleshooting instructions found in the manufacturer owner's manual.

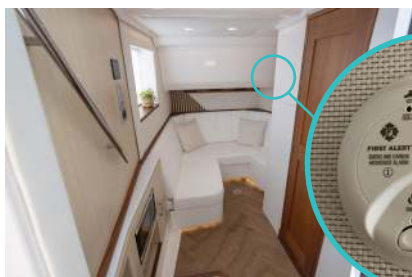

CO/smoke detector

When the alarm detects unsafe levels of CO, the indicator flashes red and the unit emits horn beeps in groups of four. If the alarm sounds:

1. Press the reset button on the unit.
2. Vacate the vessel and move to a fresh air environment as quickly as possible to avoid passing out from CO poisoning. Call emergency services. Do not return to the vessel until emergency services have given an all clear.
3. Have a qualified technician inspect the boat and fix any leaks that may have caused CO to accumulate before operating the vehicle again.

High Water Alarm



The high water alarm will sound if there is too much water in the bilge. In the event of an emergency, activate the bilge pumps manually (pages 160 and/or 188). If safe to do so, enter the bilge area (Lazarette compartment) and attempt to identify the source of the water ingress. This could be a loose hose, seacock, or cracked hull.



Care and Maintenance

Acrylic Solid Surface

Acrylic is used in surfacing applications around the vessel including the counter top, cabinet face, and the helm seat backs. Acrylic is durable and does not need as much care as other surfacing materials.



Use warm, soapy water or household surface cleaners for routine cleaning. If further attention is needed, use a 1:4 diluted bleach solution. Make sure to avoid using bleach on metal; bleach can cause corrosion. Use lint free or microfiber rags to clean acrylic without creating static discharge. Wipe dry after cleaning to avoid film building up on acrylic surfaces. Acrylic scratches easily--make sure cloths are totally clean before using to clean acrylic.

Do not use paper towels. Do not use an abrasive or scouring pad. Do not use window cleaners. Do not use organic, oil-based solvents including, but not limited to, acetone, nail polish remover, paint thinner, benzene, alcohol solutions, and carbon tetrachloride.

Polishing may help remove scratches and other marks that do not respond to basic cleaning. Use a soft, lint-free cloth to polish. After polishing, remove any residual product. For further care instructions, refer to the LG HI-MACS care and maintenance website.

Canvas

Never store canvas in a wet and/or unventilated area. Roll the canvas instead of folding. Shake out dusty canvas. Clean canvas with mild soap or detergent. Rinse thoroughly to remove dirt and debris. Incomplete rinsing may cause threads to deteriorate. Do not use bleach or other harsh chemicals. Do not steam press. Do not machine wash or machine dry. Excessive heat can damage and shrink the canvas.

Zippers and Snaps

Canvas covers have zippers. Do not force zippers closed. Do not pull on canvas to force zippers closed. A dedicated zipper lubricant may help operate new zippers and maintain old ones.

Always attach and detach canvas snap fasteners as close to the snap itself as possible. Do not remove canvas by pulling on the material. For further care instructions, refer to the TaylorMade website.

Fiberglass and Gel Coat

Outdoor exposure can cause the boat's gel coat to fade. Routine maintenance is the only way to keep it shiny and new. Wash the boat once a month with a mild detergent or dish soap. Dry as you wash to avoid calcium spots. Avoid alkaline cleaners, abrasives, bleaches, and ammonia. For best results, use dedicated gel coat cleaners. For stains in the gel coat, use an acid based, fiberglass stain remover. Follow all manufacturer safety and application instructions.

Wax the gel coat surface twice a year to protect the finish. Use fiberglass wax and follow the label instructions. Apply a 3'x3' area and use clean applicator cloths or a bonnet to buff. If a haze develops, use a power buffer at low speed to remove the haze. Keep the buffer moving to avoid heat buildup. Never wax in direct sunlight.

If washing and waxing do not restore shine, it may be necessary to use a fiberglass polish or fine rubbing compound. Do not apply a rubbing compound in direct sunlight. Use a power buffer at low speed to remove impurities from the gel coat that cause dulling. Use light pressure and keep the buffer moving. When finished, re-wax.

Interior Fabrics

Clean interior fabrics with dry cleaning, fluid style cleaners approved for use with soft fabrics. Allow adequate ventilation and follow the label instructions.

Seagrass Matting



Seagrass matting is Regal's in-house, custom deck matting that comes standard on the LX43. Seagrass matting contains Microban, a protective antimicrobial that inhibits the growth of stain and odor causing bacteria, mold, and mildew.

Air out the Seagrass matting after each outing. When removing material from the cockpit, do not pull on the material itself, instead lift from the metal snaps.

To clean the Seagrass matting, vacuum any dust or detritus, clean with a sponge and mild detergent, rinse with a hose, and hang to dry. Do not wash Seagrass in the washing machine.

Seagrass mats feature urethane backing designed for marine environments. When storing the Seagrass mats, always roll with the backing facing in. Do not fold or crease to avoid splitting the backing.



Seagrass mat example

ReFlex Flooring

The vessel may be equipped with optional grey ReFlex or Synthetic Teak ReFlex matting. Matting is made of UV protected, non-absorbent foam that stays cool to the touch and maintains traction even when wet. Upgraded matting is designed to resist stains and, most of the time, hosing down the matting is enough to keep it clean. If more thorough cleaning is required, use any non-acid based household cleaners and soft rags or soft bristle brushes to remove any dirt or residue.



Synthetic teak example

Metal

Keep all stainless steel and other metal parts rinsed and wiped dry. To maintain their finish annually polish the stainless steel and other bright works at least annually. Use commercially available metal products and read the labels carefully before use. Refer to the flier in the owners information pouch. Most marinas and boating retail outlets carry metal care products.

Plastic

Use marine-specific cleaners and polishes. Use proper applicators. Read all instructions carefully. Test the product on a small area first. Apply with a soft rag and rinse the surface with water. Do not use ammonia based cleaners and abrasives.



Stainless Steel



Select cosmetic hardware including interior drains, grab rails, brake light covers, and select gas ramps are all stainless steel. Stainless steel is more durable and resistant to corrosion than other metal finishes.

To clean stainless steel hardware, use any typical stainless steel cleaner. Avoid using hard bristle brushes and avoid scratching the stainless steel hardware. Stainless steel is expensive to fix and oftentimes replacing an entire piece is more cost effective than repairing even the smallest scratch.

Upholstery

Clean the cockpit and interior vinyl periodically to prevent dirt and mildew buildup. Contaminates may stain and reduce vinyl life.

Clean common stains with warm, soapy water. Scrub with a soft bristle brush to loosen dirt and

grime from embossed surfaces and under welting. For tougher stains, use a mild household cleaner.

For best results, remove stains immediately, before they penetrate the vinyl. Do not use powdered abrasives, steel wool, or industrial strength cleaners on upholstery. Do not wax vinyl. Use tanning lotion instead of tanning oil to avoid damaging upholstery. Do not leave upholstery exposed to the sun for long periods. Use canvas covers whenever the boat is not in use.

UltraLounge

To ensure the UltraLounge maintains smooth functionality, make sure to clean the metal supports for the backrest and the railings in the crevices near the armrests. Rinse it with freshwater or pressurized air. NEVER use grease to lubricate as it allows debris to stick to and build up within the UltraLounge, affecting its mobility and functionality. Make sure to clean the upholstery of the UltraLounge as well.

Chill Cool Vinyl

The vessel may come equipped with optional Chill Cool Technology vinyl. Chill Cool vinyl keeps the seats cool after hours in the sun. Caring for Chill Cool vinyl is slightly different from regular upholstery.

To clean Chill Cool Vinyl, use a soft cloth submerged in a mixture of 30:1 warm water to mild, non-bleach dish soap. Gently rub away any dirt or residue and then rinse with clean, warm water and wipe dry.

NEVER use bleach or bleach containing products, like eraser sponges, to clean your vinyl. Failure to care for the vinyl may damage it and is not included in your warranty.



Hull Bottom

Fiberglass hulls are strong, but can be damaged. When a part of the hull is broken or punctured, the rest of the hull will retain its shape. A severe blow will either be absorbed or cause a localized break. A break in the hull should be repaired by your Regal dealer.

Clean the hull bottom regularly to eliminate marine contaminants that may affect performance. Never use wire brushes or abrasive scouring pads on the hull bottom. Abrasives could damage the gel coat or bottom paint. The bottom of the boat needs to be clean as the build up of natural coatings from water or marine life can potentially create drag and affect the boat's performance.



Final Acknowledgments

We would like to welcome you again to the Regal family. We are happy you are here and look forward to sharing your boating journey with you. Thank you for taking the time to read this manual and become familiar with the operation and maintenance of your Regal LX43.



Please refer to third party, manufacturer owner's manuals, included in your owner's welcome packet, for detailed information on technical features, equipment, operation, maintenance, and troubleshooting. You should have received your owner's welcome packet during the new boat delivery process. If you did not receive your welcome packet, contact your Regal dealer. You can access all Regal manuals online by going to <https://www.regalboats.com/owners-resources/>.

For any questions or issues that you can not answer using the manuals, please contact your authorized Regal Dealer or call our customer service line at 1(800) 877-3425.



TROUBLESHOOTING

The following diagnostic information will assist you in identifying minor electrical, fuel, and mechanical problems. Some of the items listed require technical training and tools. Additional assistance is available in the engine manufacturer's owner's manual. Also, you can contact your closest Regal dealer or marine professional for more information. Sometimes a problem can be solved by performing a logical sequence of elimination and/or root cause techniques.

 WARNING

AVOID SERIOUS INJURY OR DEATH!
BEFORE PERFORMING ANY MAINTENANCE
WORK, TURN OFF THE BATTERY SWITCH
AND REMOVE THE IGNITION KEY(S)
FROM THE SWITCH.

 WARNING

AVOID SERIOUS INJURY OR DEATH!
USE ONLY APPROVED MARINE
REPLACEMENT PARTS THAT
ARE IGNITION PROTECTED.

Engine Diagnostic Chart

Problem	Possible Cause
Engine Overheating	<p>Water pick-up feeds are blocked by debris. Clear intake of debris.</p> <p>Cooling system leak. Service at dealer.</p> <p>Impeller is worn or blocked by debris. Clear debris. Service at dealer if issue persists.</p> <p>Propeller is over propped for the circumstances, causing the engine to work extra hard. Service at dealer.</p> <p>Debris in oil is holding heat more than normal - defective oil filter. Change oil filter. If issue persists, service at dealer.</p> <p>Defective thermostat. Service at dealer.</p> <p>Faulty temperature sender. Service at dealer.</p>

Engine Diagnostic Chart

Problem	Possible Cause
Starter Will Not Crank	<p>Battery weak or dead. Charge/replace battery. Service at dealer if issue persists.</p> <p>Starter defective. Service at dealer.</p> <p>Fuse for electric start relay blown. Replace fuse. Service at Dealer if issue persists.</p> <p>Control not in neutral. Return throttle to neutral.</p> <p>Defective start panel button. Service at dealer.</p>
Excessive Steering Play	<p>Air in steering lines. Bleed lines. Service at dealer if issue persists.</p> <p>System low on steering fluid. Add steering fluid.</p> <p>Mechanical parts-loose connection. Tighten connections. Service at dealer if issue persists.</p>

Engine Diagnostic Chart

Problem	Possible Cause
No Power To Helm	<p>Battery switch turned off. Turn switch on.</p> <p>Batteries are weak or dead. Charge/replace batteries.</p> <p>Main breaker tripped. Reset breaker. Service at dealer if issue persists.</p> <p>Loose connection. Tighten connections. Service at dealer if issue persists.</p>
Engine Cranks But Will Not Start	<p>Fuel flow obstructed/water in fuel. Drain fuel lines. Service at dealer if issue persists.</p> <p>Low battery voltage. Charge/replace batteries.</p> <p>Engine ignition system malfunction. Service at dealer.</p> <p>Timing belt broken. Replace belt.</p> <p>No fuel in tank. Fill fuel tank.</p> <p>Control not in neutral. Return throttle to neutral.</p>

Engine Diagnostic Chart

Problem	Possible Cause
Hard Starting	<p>Vacuum In Fuel System. Service at dealer.</p> <p>Fuel lines obstructed. Service at dealer.</p> <p>Water in fuel. Flush fuel lines. Service at dealer if issue persists.</p> <p>Debris in fuel/clogged fuel filter. Service at dealer.</p>
Engine Idles/ Runs Rough	<p>Old fuel. Replace fuel.</p> <p>Faulty spark plugs. Replace spark plugs.</p> <p>Fuel contaminated/ clogged anti-siphon. Service at dealer.</p>

Engine Diagnostic Chart

Problem	Possible Cause
Power Loss	<p>Damaged propeller. Replace propeller.</p> <p>Improper trim angle. Trim engine. Service at dealer if issue persists.</p> <p>Spark plugs fouled. Replace spark plugs.</p> <p>Fuel system malfunction. Service at dealer.</p> <p>Hull bottom fouled with debris. Clean hull. Service at dealer if issue persists.</p> <p>Excess water in bilge. Service at dealer.</p> <p>Engine needs tune-up. Service at dealer.</p>

Engine Diagnostic Chart

Problem	Possible Cause
Excessive Vibration	<p>Damaged propeller. Replace propeller.</p> <p>Damaged propeller shaft. Service at dealer.</p> <p>Loose/broken motor mount. Service at dealer.</p> <p>Steering pivot loose or damaged. Service at dealer.</p> <p>Debris caught on propeller. Remove debris.</p> <p>Ignition malfunction. Service at dealer.</p> <p>Motor mount bolts loose. Service at dealer.</p>
Buzzer Sounds/Icon Lights	<p>Cooling system malfunction. Service at dealer.</p> <p>Engine oil level low or incorrect type. Fill/replace oil. Service at dealer if issue persists.</p> <p>Wrong spark plug heat range. Replace spark plug.</p> <p>Oil feed pump malfunction. Service at dealer.</p>

DC Electrical Diagnostic Chart

Problem	Possible Cause
No 12 Volt Power At Battery	<p>Charging system inoperative. Service at dealer.</p> <p>Weak or dead battery. Charge/replace battery. Service at dealer if issue persists.</p> <p>Battery cables loose/disconnected. Reconnect/tighten cables.</p> <p>Battery cables corroded. Service at dealer.</p>
Battery Not Charging While Engine Is Running	<p>Faulty stator/alternator. Service at dealer.</p> <p>Faulty circuit wiring. Service at dealer.</p>
Battery Will Not Hold Charge	<p>Faulty/old battery. Replace battery.</p> <p>Loose battery cables. Tighten cables.</p> <p>Corroded battery terminals. Replace battery</p>

DC Electrical Diagnostic Chart

Problem	Possible Cause
12V Equipment Not Working	<p>Fuse blown. Replace fuse. Service at dealer if issues persist.</p> <p>Weak or dead battery. Charge/ Replace battery.</p> <p>Corroded wire connection. Service at dealer.</p> <p>Loose wire connection. Tighten connection.</p> <p>Internal equipment short /failure. Service at dealer.</p>

AC Electrical Diagnostic Chart

Problem	Possible Cause
No Voltage At Main AC Panel	<p>Ships dock side cord not plugged in. Plug in cord.</p> <p>Dock side breaker tripped. Reset dockside breaker.</p> <p>ELCI breaker tripped. Reset breaker.</p> <p>Faulty dock side power cord. Replace cord.</p>
AC Panel Indicates Reverse Polarity	Dockside wires reversed at marina power supply. Contact marina owner.
No Voltage At GFCI outlets	<p>GFCI outlet tripped. Reset breaker.</p> <p>Outlet breaker off at AC main ship's panel. Turn on breaker panel.</p> <p>Faulty equipment plugged in. Unplug faulty equipment.</p>
Main AC Panel Breakers Trip When All Equipment Is Energized	Turn off equipment as needed to balance load on shore 1 and shore 2

COMMON STAINS/CLEANING

	1	2	3
Coffee, Tea, Chocolate.....	B		
Permanent Marker*.....	E	B	C
Household Dirt.....	A	B	
Grease.....	D	B	
Ketchup, Tomato Products.....	A	B	
Latex Paint.....	A	B	
Oil Base Paint.....	D	B	
Mustard.....	A	B	C
Suntan Oil.....	A	B	
Asphalt/Road Tar.....	D	B	
Crayon.....	D	B	
Engine Oil.....	B		
Spray Paint.....	B		
Chewing Gum.....	D	A	
Shoe Polish*.....	D	B	
Ballpoint Pen*.....	E	B	A
Lipstick.....	A	B	
Eyeshadow.....	E	B	
Mildew*.....	C	B	A
Wet Leaves *.....	C	B	A

A= Soft brush; warm soapy water/rinse/ dry

B= Fantastik cleaner

C= One tablespoon ammonia, 1/4 cup of hydrogen peroxide, 3/4 cup of warm water/ rinse/dry

D= Scrape off residue (use ice to lift gum)

E= Denatured alcohol/rinse/dry

* These products contain dyes which leave permanent stains.

Parts of a Boat

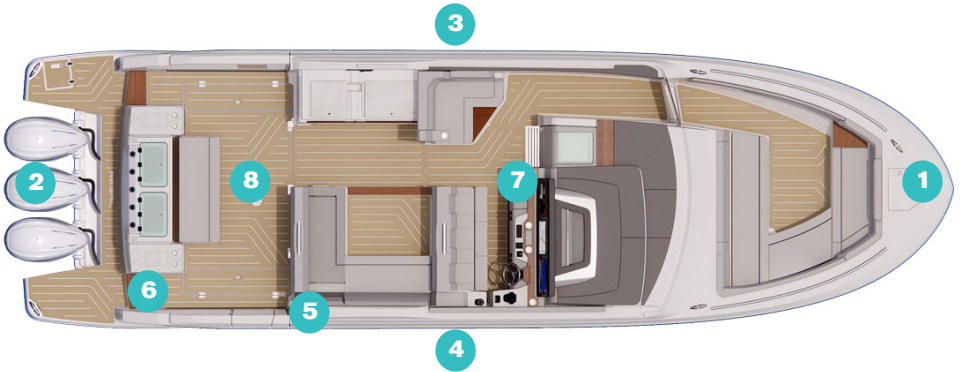

1 - Bow: The front of the boat.

2 - Stern: The rear of the boat.

3 - Port: Left (facing the bow).

4 - Starboard: Right (facing the bow).

5 - Gunwale: The upper edge of the boat.

6 - Transom: The flat edge of the back of the boat.

7 - Helm: The boat's steering equipment.

8 - Lazarette Hatch: The storage area for the engines and other equipment.

Side View

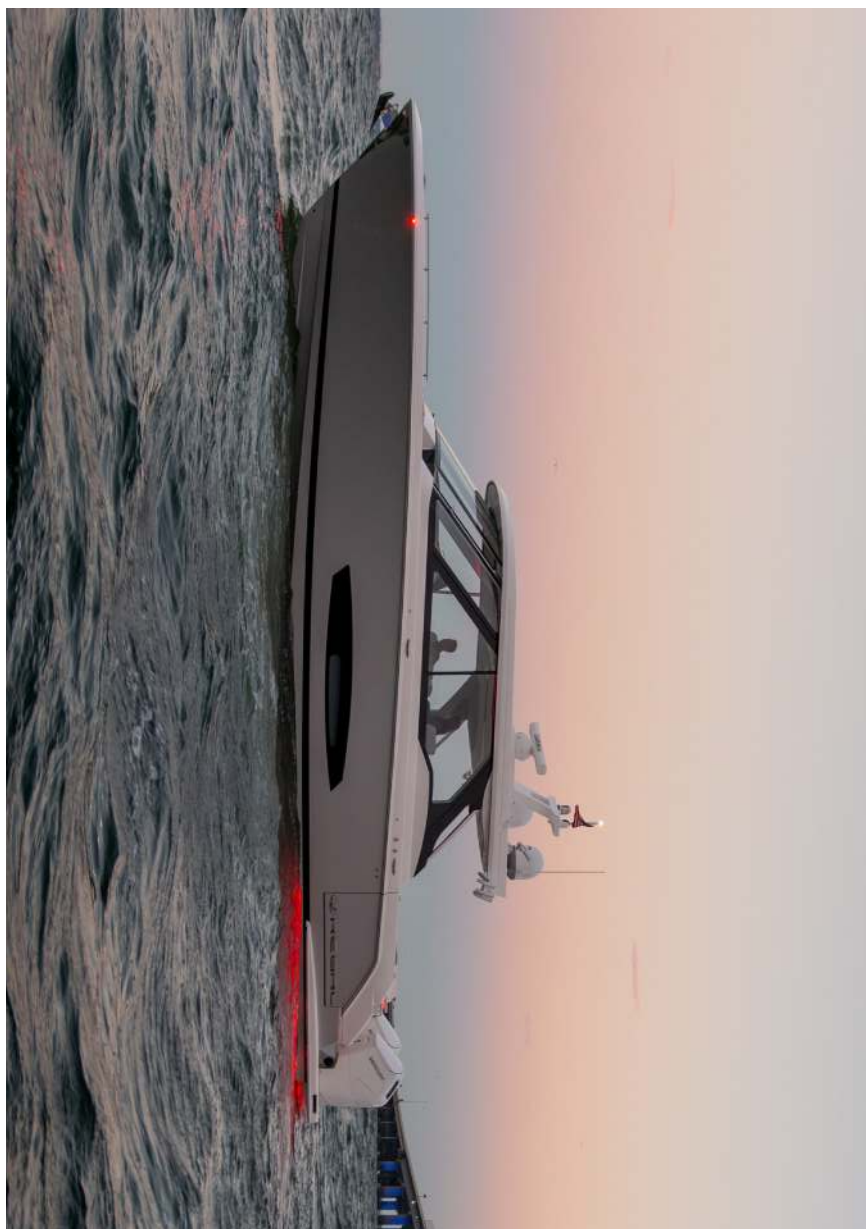

Top View



Cabin View



Seating Capacity



CE Seating Occupancy: 18 Persons

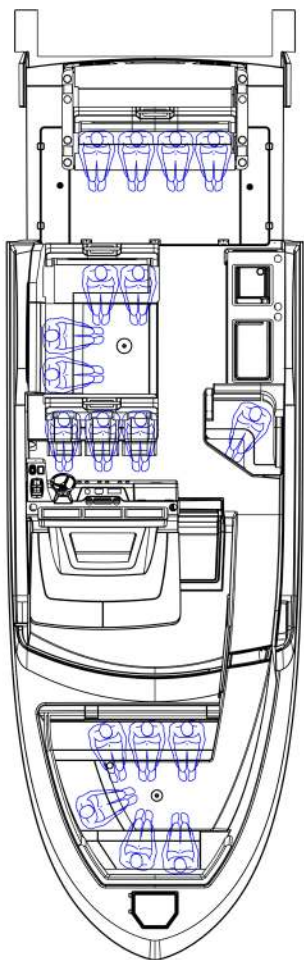

REGAL MARINE INDUSTRIES
11/17/2025
TRG

 <p>REGAL MARINE INDUSTRIES 11/17/2025 TRG</p>		<p>REGAL MARINE INDUSTRIES 11/17/2025 TRG</p>	<p>REGAL MARINE INDUSTRIES 11/17/2025 TRG</p>
<p>REGAL MARINE INDUSTRIES 11/17/2025 TRG</p>		<p>REGAL MARINE INDUSTRIES 11/17/2025 TRG</p>	<p>REGAL MARINE INDUSTRIES 11/17/2025 TRG</p>

Lifting Strap Placements

FX Lifting Strap Locations

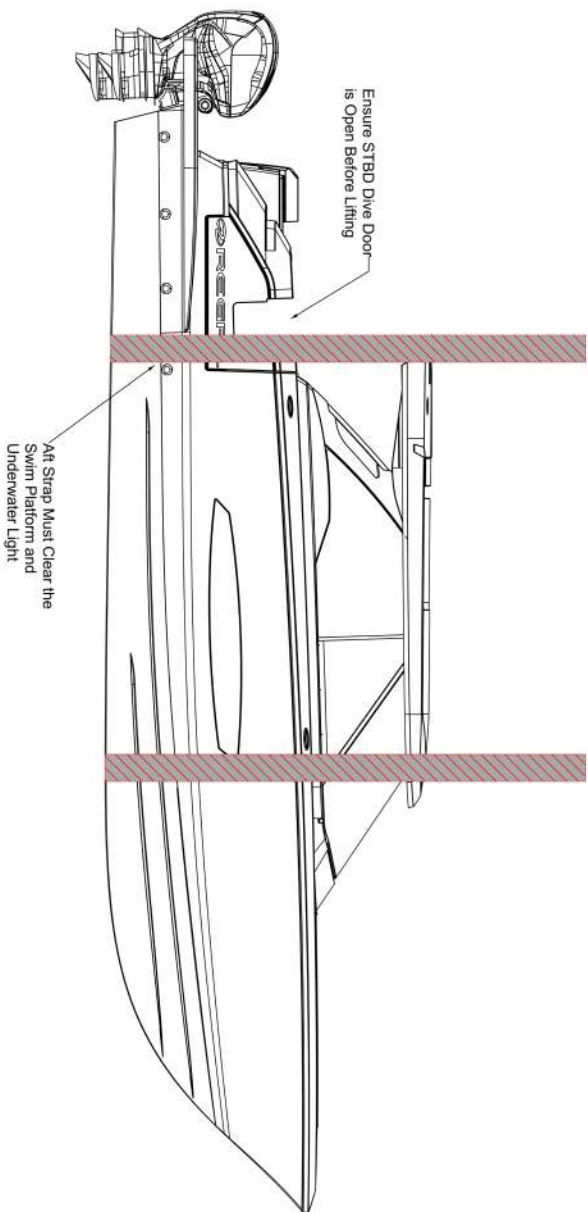

REFERENCE ONLY

REGAL MARINE INDUSTRIES
 1728/2025
 WCP

 REGAL MARINE INDUSTRIES <small>REGAL MARINE INDUSTRIES</small> <small>ALL RIGHTS RESERVED</small>	
<small>DOCUMENT TITLE</small> FX Lifting Strap Locations	<small>DATE</small> 1/28/2025
<small>DESIGNER</small> WCP	<small>PROJECT CODE</small> -
<small>ISSUE NO.</small> 1 OF 6	<small>ISSUE DATE</small> MFX25S

Deck Hardware - 1

FX Deck Hardware

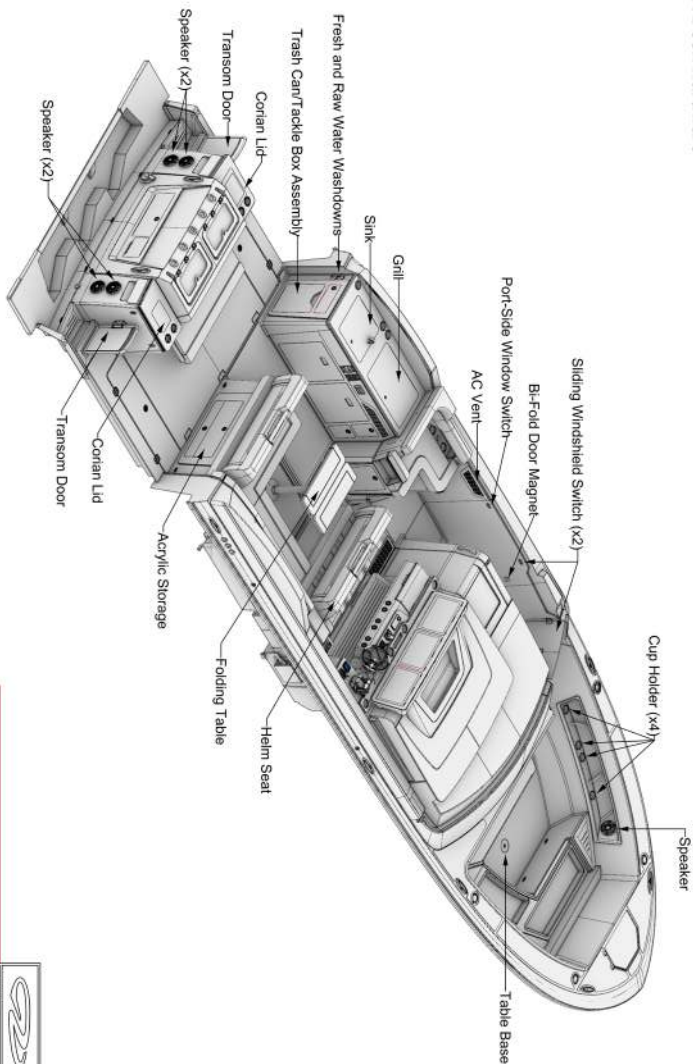

REFERENCE ONLY

REGAL MARINE INDUSTRIES, INC. IS NOT RESPONSIBLE FOR ANY DAMAGE TO YOUR VESSEL OR EQUIPMENT CAUSED BY THE USE OF THIS HARDWARE. ALWAYS FOLLOW THE INSTALLATION INSTRUCTIONS AND WEAR YOUR SAFETY BELT AT ALL TIMES.

 REGAL MARINE INDUSTRIES <small>THE BOAT CONNECTION</small> <small>ALL RIGHTS RESERVED</small>	
QUANTITY	1
DATE	4/15/2025
TIME	10:00 AM
BY	WCP
DESCRIPTION	FX Deck Hardware
QUANTITY	1 OF 8
DATE	4/15/2025
TIME	10:00 AM
BY	WCP

Deck Hardware - 2

FX Deck Hardware
Top View

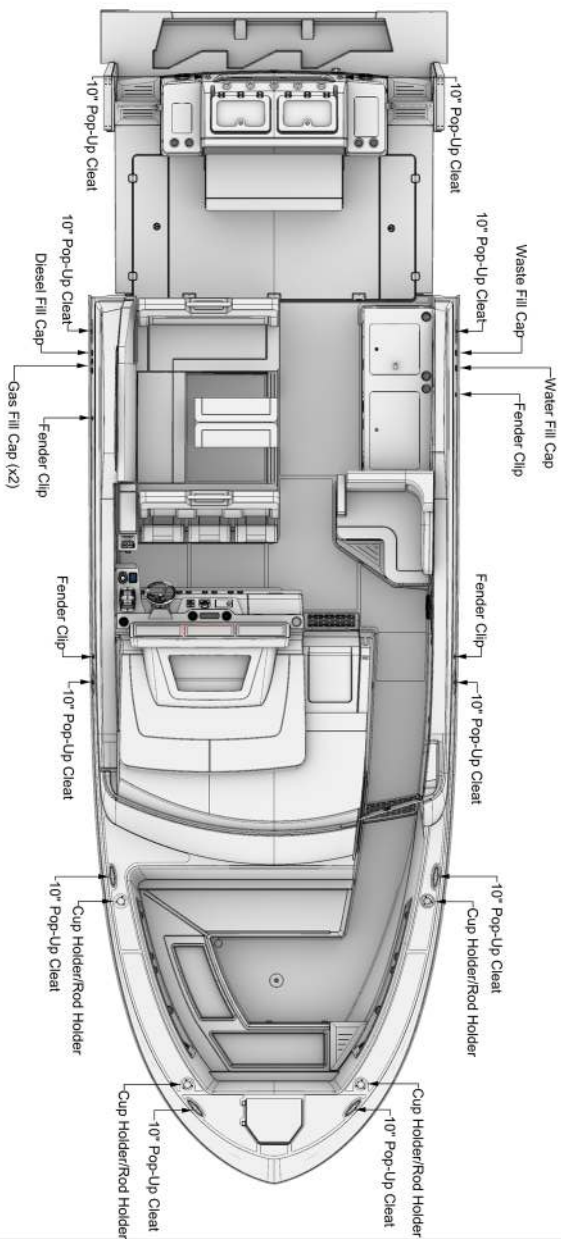

REFERENCE ONLY

REGAL MARINE INDUSTRIES, INC. IS NOT RESPONSIBLE FOR ANY DAMAGE TO YOUR VESSEL OR EQUIPMENT CAUSED BY THE USE OF THIS HARDWARE. ALWAYS FOLLOW THE MANUFACTURER'S INSTRUCTIONS AND SAFETY WARNINGS.

 <p>REGAL MARINE INDUSTRIES 1000 W. 10TH AVENUE ANN ARBOR, MI 48106-1000</p>		<p>ALL RIGHTS RESERVED</p>	
<p>DOCUMENT TITLE</p> <p>FX Deck Hardware</p>	<p>DATE</p> <p>4/19/2025</p>	<p>VERSION</p> <p>2 OF 9</p>	<p>PROJECT</p> <p>WCP</p>
<p>REVISED BY</p> <p>MF25E</p>	<p>DATE</p> <p>MF25E</p>	<p>REVISED BY</p> <p>MF25E</p>	<p>DATE</p> <p>MF25E</p>

Deck Hardware - 3

FX Deck Hardware (Ultralounge)

Bow

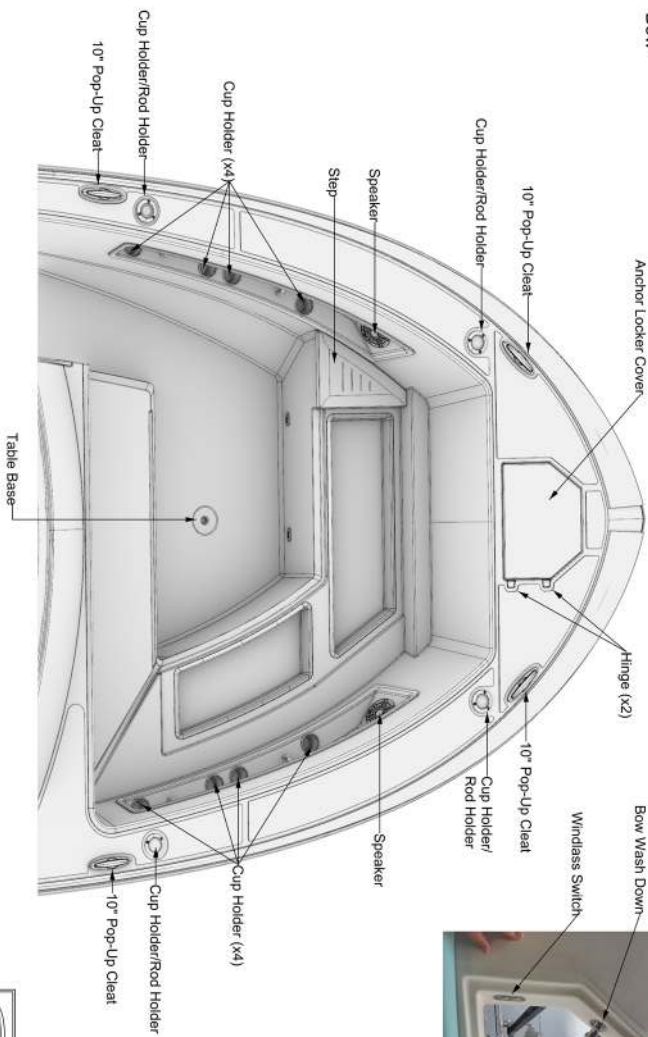

REFERENCE ONLY

THIS INFORMATION IS FOR REFERENCE ONLY. IT IS NOT A CONTRACT AND DOES NOT GUARANTEE THE PERFORMANCE OF ANY PRODUCT. ALWAYS REFER TO THE PRODUCT MANUAL FOR THE MOST CURRENT INFORMATION.

 REGAL MARINE INDUSTRIES <small>REGAL MARINE INDUSTRIES, INC. ALL RIGHTS RESERVED</small>	
<small>ISSUE DATE</small> 4/15/2025	<small>VERSION</small> 3 OF 9
<small>ISSUE BY</small> WCP	<small>REVISED BY</small> MFX28E

FX Deck Hardware

Deck Hardware - 5

FX Deck Hardware Companion Seat

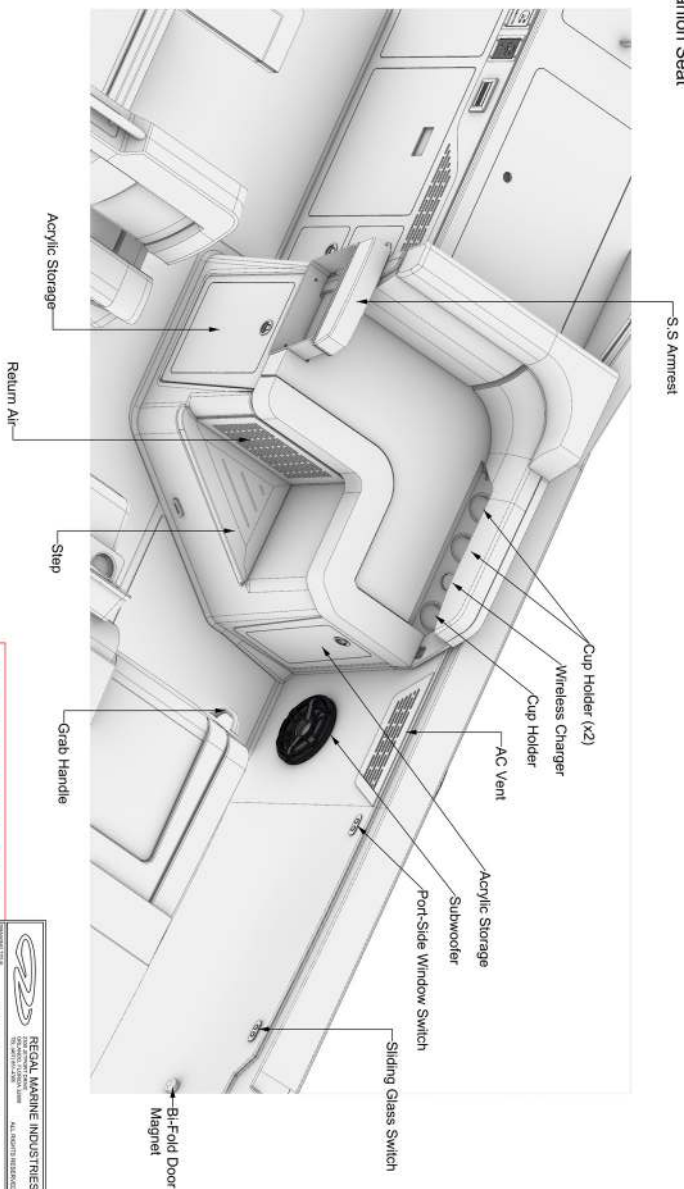

REFERENCE ONLY

FOR PARTS AND COMPATIBILITY INFORMATION, SEE THE FX DECK HARDWARE COMPANION SEAT USER MANUAL. THE INFORMATION CONTAINED HEREIN IS SUBJECT TO CHANGE WITHOUT NOTICE.

 REGAL MARINE INDUSTRIES <small>20000 W. COUNTY ROAD 100, SUITE 100 FORT WORTH, TEXAS 76150</small> <small>ALL RIGHTS RESERVED</small>	
<small>PRODUCT CODE</small> 41132025	<small>PRODUCT NAME</small> FX Deck Hardware
<small>REVISED BY</small> MCP	<small>REVISED DATE</small> 5 OF 9 <small>TRUCK PART NUMBER</small> MF229E

Deck Hardware - 6

FX Deck Hardware Weiblar

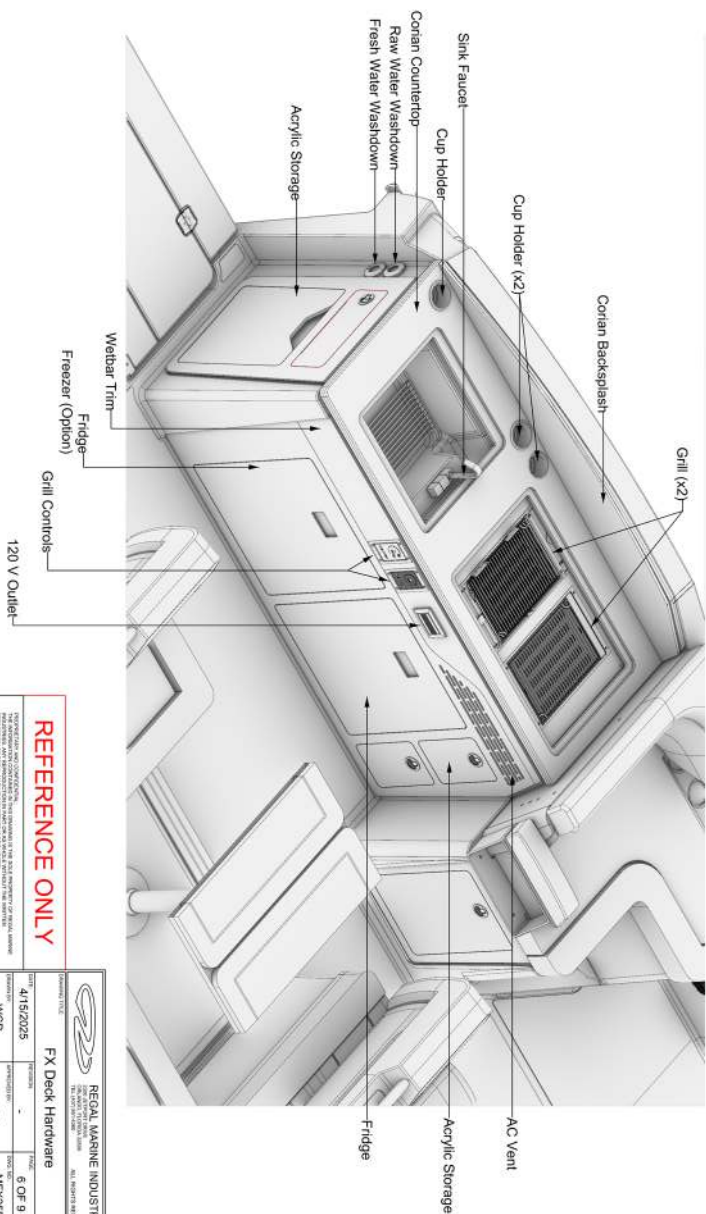

REFERENCE ONLY

THIS INFORMATION IS FOR REFERENCE ONLY. THE INFORMATION CONTAINED HEREIN IS SUBJECT TO THE FINAL TERMS OF THE SALES AGREEMENT. THE INFORMATION CONTAINED HEREIN IS NOT TO BE USED FOR ANY OTHER PURPOSES WITHOUT THE WRITTEN PERMISSION OF REGAL MARINE INDUSTRIES. © 2015 REGAL MARINE INDUSTRIES

 REGAL MARINE INDUSTRIES 10000 W. Highway 100, Suite 100 Jacksonville, FL 32256-4400 TEL: 904.733.8888	
COMPANY TITLE FX Deck Hardware	PART NUMBER 6 OF 9
DATE 4/15/2015	VERSION MPX2AE
PROJECT WCP	DRAWING NO. MPX2AE

Deck Hardware - 7

FX Deck Hardware Cockpit

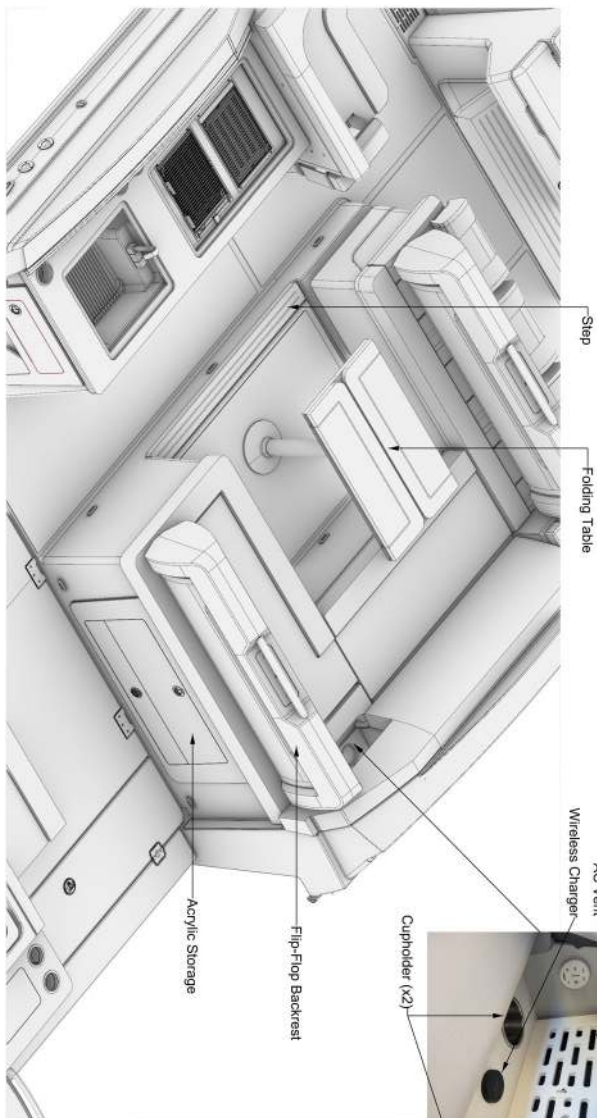

REFERENCE ONLY

REGAL MARINE INDUSTRIES
 10000 W. 10th Street, Suite 100
 Minneapolis, MN 55426
 (612) 835-1111
 www.regalmarine.com

 <p>REGAL MARINE INDUSTRIES 10000 W. 10th Street, Suite 100 Minneapolis, MN 55426 (612) 835-1111 www.regalmarine.com</p>	<p>APPROVED TITLE: FX Deck Hardware</p> <p>DATE: 4/15/2025</p> <p>DRAWN BY: WCP</p> <p>ISSUED BY: MPX2AE</p> <p>REVISED BY: -</p> <p>REVISED DATE: -</p> <p>REVISED REASON: -</p> <p>REVISED BY: -</p> <p>REVISED DATE: -</p> <p>REVISED REASON: -</p>
-----------------------------------------------------------------------------------------------------------------------------------------------------------------------------------------------------------------------------------------------------------------	------------------------------------------------------------------------------------------------------------------------------------------------------------------------------------------------------------------------------------------------------------------------------------------------------------------------------

Deck Hardware - 8

FX Deck Hardware Tombstone

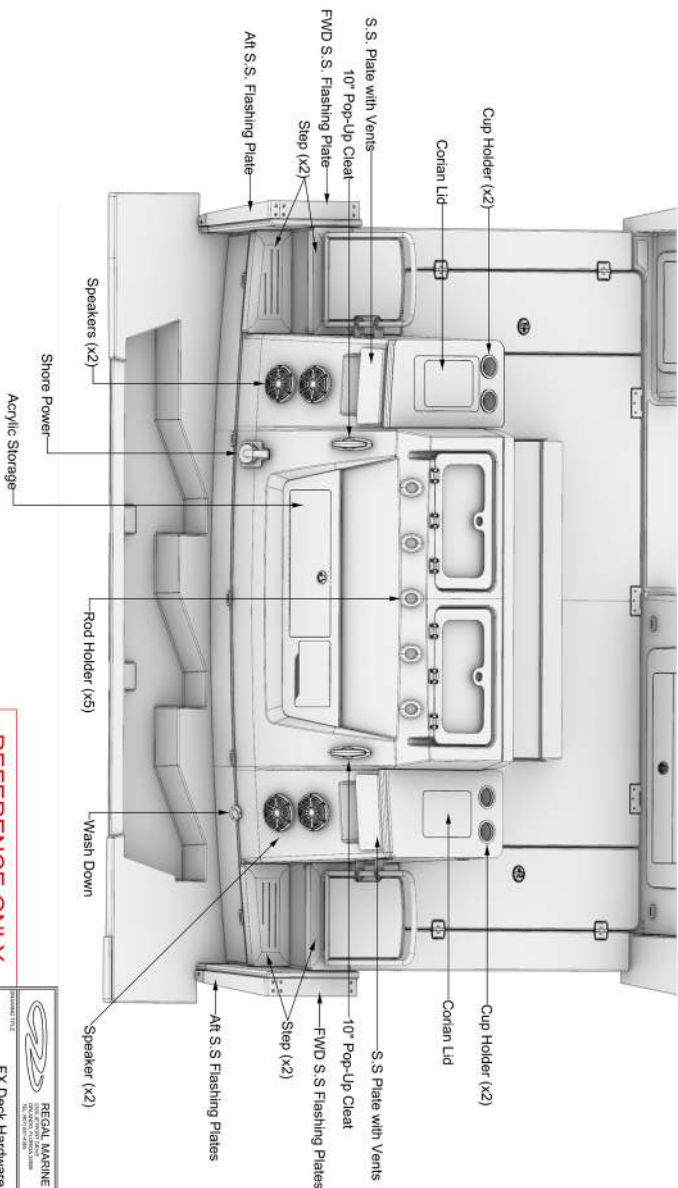

REFERENCE ONLY

The information contained in this drawing is the property of Regal Marine Industries, Inc. and is to be used for reference only. It is not to be used for reproduction or other purposes without the written permission of Regal Marine Industries, Inc.

 REGAL MARINE INDUSTRIES <small>DESIGN • BUILD • SERVICE</small> <small>ALL RIGHTS RESERVED</small>			
ISSUE NO.	41192025	REVISED BY	WCP
ISSUE DATE	8 OF 9	ISSUE NO.	MF25E
FX Deck Hardware			

Deck Hardware - 9

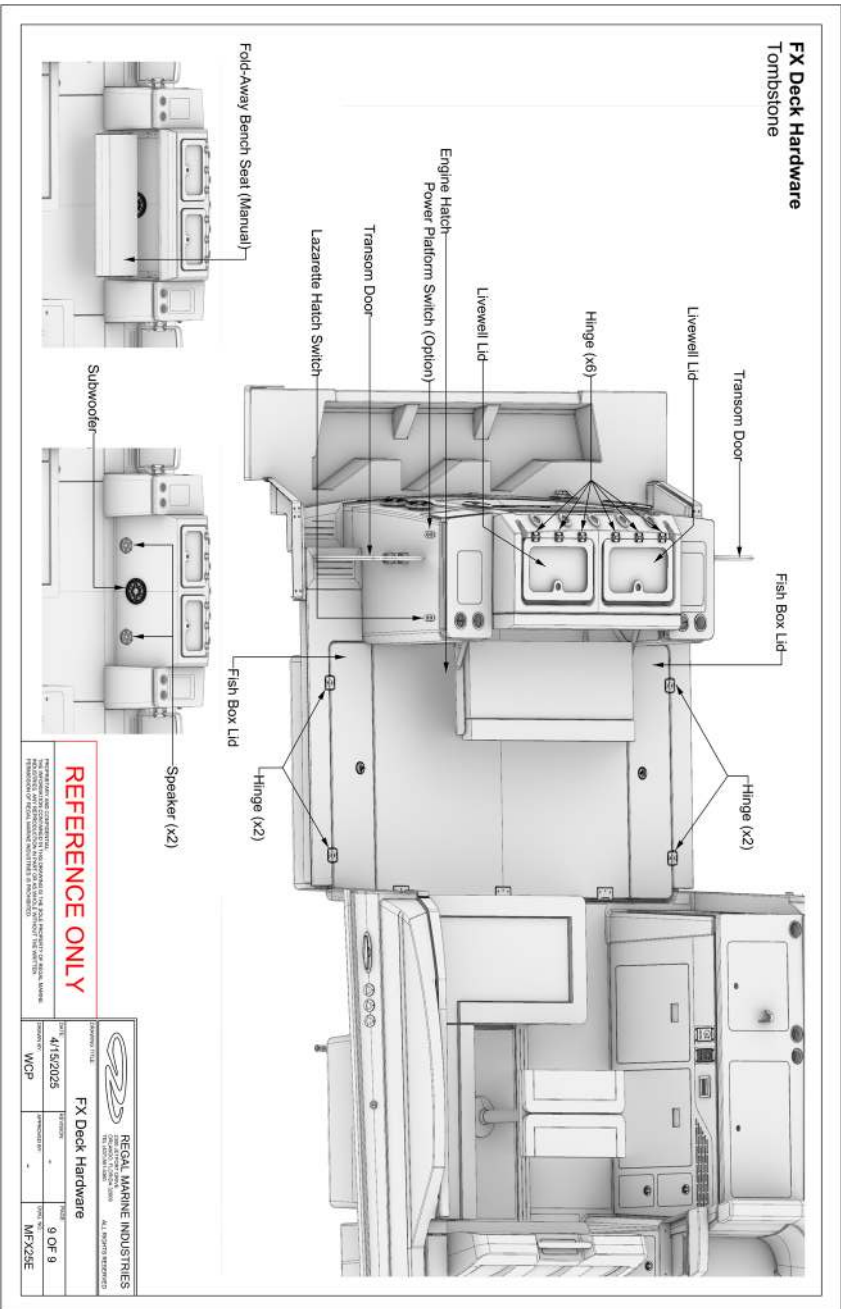

Rod Holder Angles

FX Rod Holder Angles

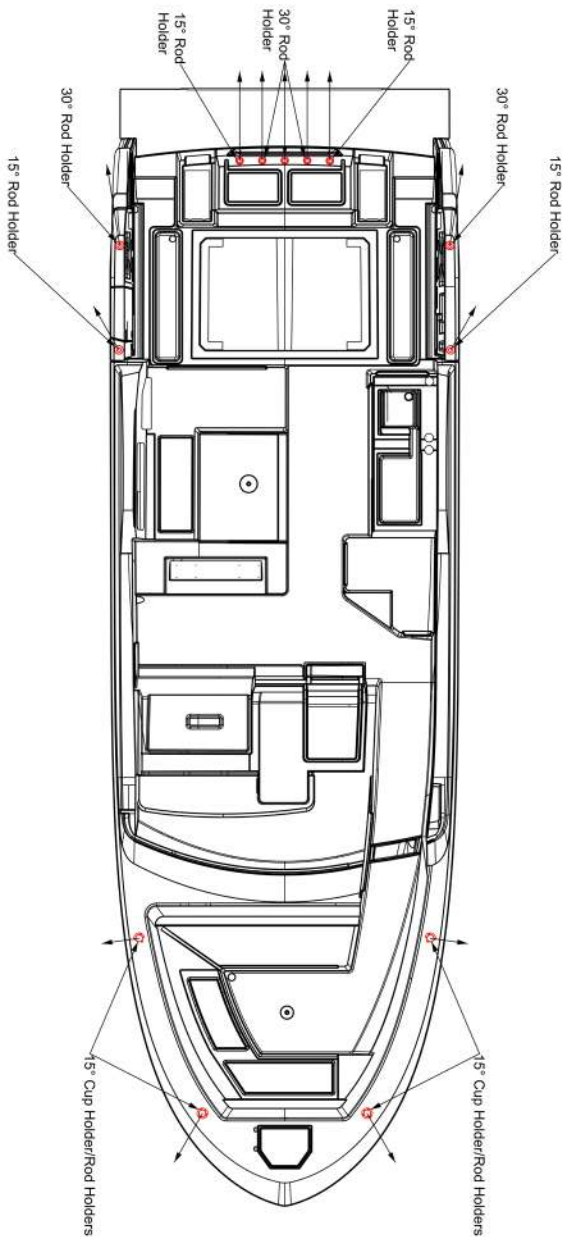

REFERENCE ONLY

REGAL MARINE INDUSTRIES, INC. IS NOT RESPONSIBLE FOR ANY DAMAGE TO YOUR BOAT OR EQUIPMENT CAUSED BY THE USE OF THIS INFORMATION. THE INFORMATION IS PROVIDED AS A SERVICE TO OUR CUSTOMERS AND IS NOT INTENDED TO BE USED AS A SUBSTITUTE FOR PROFESSIONAL ADVICE.

 REGAL MARINE INDUSTRIES <small>10000 W. 30th Avenue, Fort Lauderdale, FL 33309</small> <small>ALL RIGHTS RESERVED</small>	
DRAWING TITLE FX Rod Holder Angles	PART NO. 1 OF 1
DATE 1/28/2025	DRAWN BY WCP
CHECKED BY -	PART NO. MF295K

Hull Hardware - 1

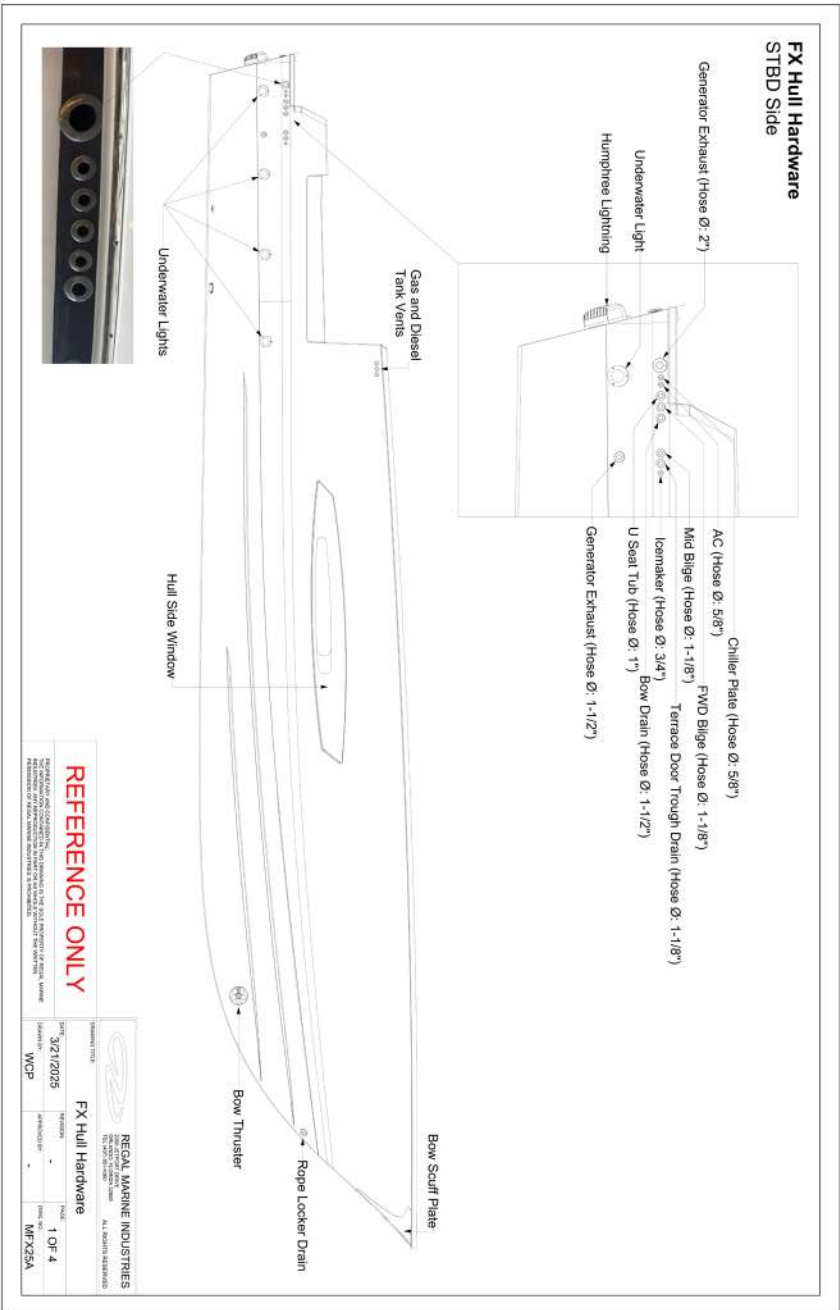

REFERENCE ONLY

THIS DRAWING AND CONTENTS ARE THE PROPERTY OF REGAL MARINE INDUSTRIES. ANY REPRODUCTION OR TRANSMISSION OF THIS DRAWING OR CONTENTS WITHOUT THE WRITTEN PERMISSION OF REGAL MARINE INDUSTRIES IS PROHIBITED.

<p>REGAL MARINE INDUSTRIES 10000 W. CENTRAL EXP. HWY. SUITE 100 MIRAMAR, CA 92457-1000 ALL RIGHTS RESERVED</p>	
DRAWING TITLE	FX Hull Hardware
DATE	3/21/2025
DESIGNED BY	WCP
REVISED BY	
SCALE	1 OF 4
DRAWING NO.	MFX25A

Hull Hardware - 2

FX Hull Hardware Port Side

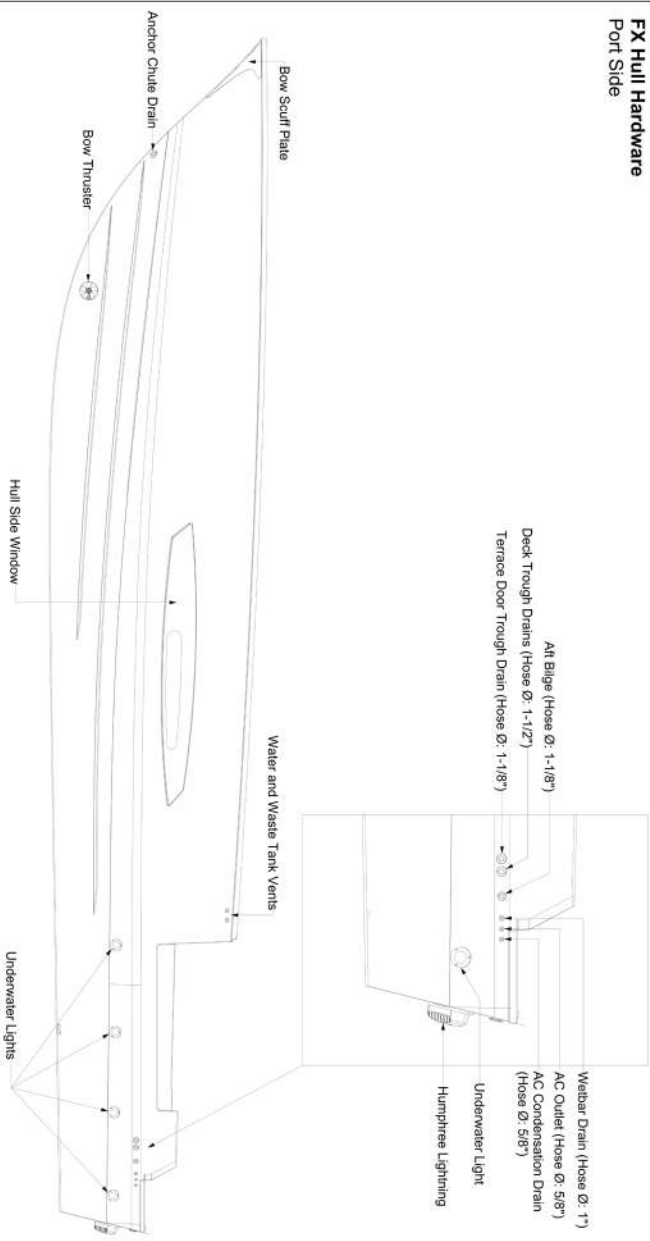

REFERENCE ONLY

REGAL MARINE INDUSTRIES
 10000 10th Street, Richmond, BC V6V 1G7, Canada
 Phone: 604-271-2205 Fax: 604-271-2206
 Email: sales@regalmarine.com Website: www.regalmarine.com

 REGAL MARINE INDUSTRIES <small>THE MARINE CONNECTION</small> <small>ALL RIGHTS RESERVED</small>	
REVISED TITLE 3212/2025 WCP	FX Hull Hardware INCHES PART: 2 OF 4 MODEL: MF-25A

Hull Hardware - 3

FX Hull Hardware Transom

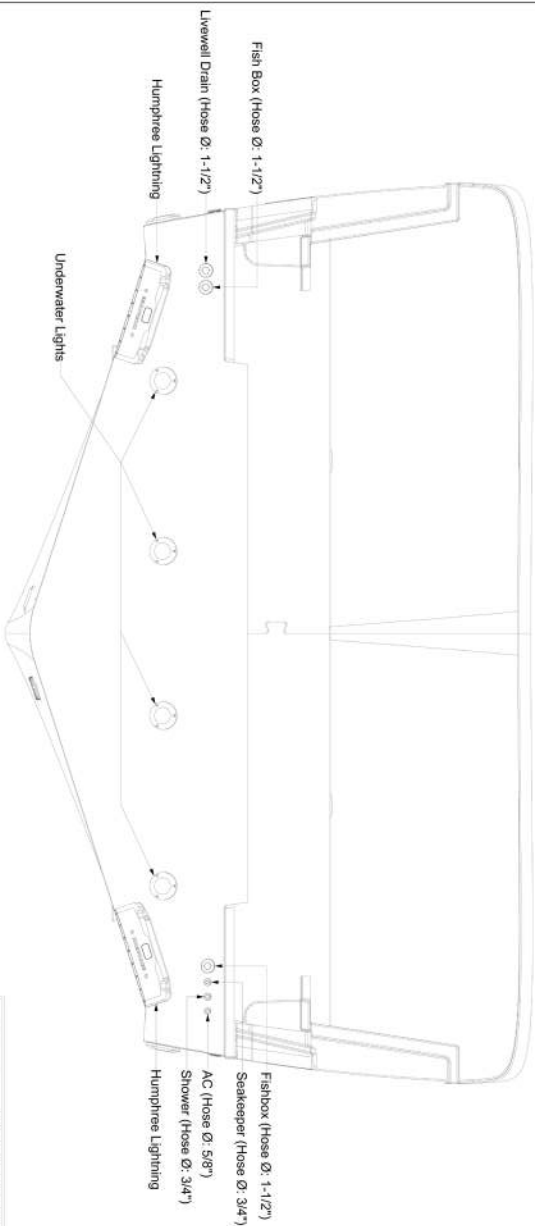

REFERENCE ONLY

REGAL MARINE INDUSTRIES INC. IS NOT RESPONSIBLE FOR THE PROPER INSTALLATION OF THE HARDWARE OR THE RESULTS THEREOF. THE USER MUST REFER TO THE INSTALLATION MANUAL FOR THE HARDWARE FOR THE PROPER INSTALLATION AND MAINTENANCE PROCEDURES.

 <p>REGAL MARINE INDUSTRIES 2000 N. 10th Street Fort Lauderdale, FL 33304 Tel: 954.321.1205 Fax: 954.321.1206</p>	
<p>Model: FX Hull Hardware</p>	<p>Part No: 32112025</p>
<p>Material: WCP</p>	<p>Page: 3 OF 4</p>
<p>Part No: MF25A</p>	<p>Part No: MF25A</p>

Hull Hardware - 4

FX Hull Hardware Bow

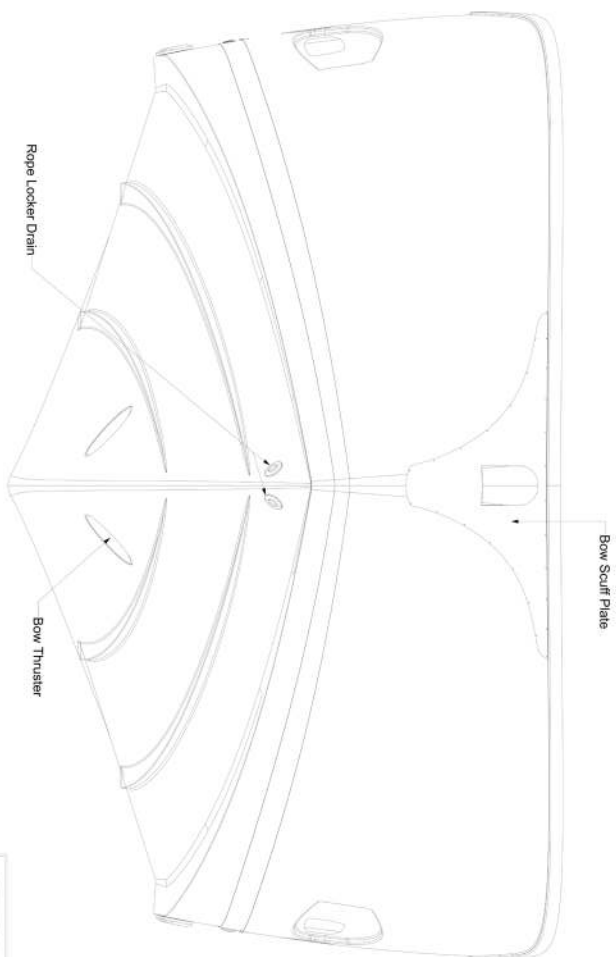

REFERENCE ONLY

THE INFORMATION CONTAINED IN THIS DOCUMENT IS THE PROPERTY OF REGAL MARINE INDUSTRIES. IT IS TO BE USED FOR IDENTIFICATION PURPOSES ONLY AND IS NOT TO BE REPRODUCED OR TRANSMITTED IN ANY FORM OR BY ANY MEANS, ELECTRONIC OR MECHANICAL, INCLUDING PHOTOCOPYING, RECORDING, OR BY ANY INFORMATION STORAGE AND RETRIEVAL SYSTEM.

 REGAL MARINE INDUSTRIES <small>REGAL MARINE INDUSTRIES</small> <small>10000 W. 40th Street, Fort Lauderdale, FL 33322</small> <small>ALL RIGHTS RESERVED</small>	
PART NUMBER 912112025	PART NAME FX Hull Hardware
QUANTITY WCP	QUANTITY 4 OF 4
PART NUMBER MPZ5A	PART NAME MPZ5A

Hardtop Hardware - 1

FX Hardtop Hardware A-Side with Mast Option

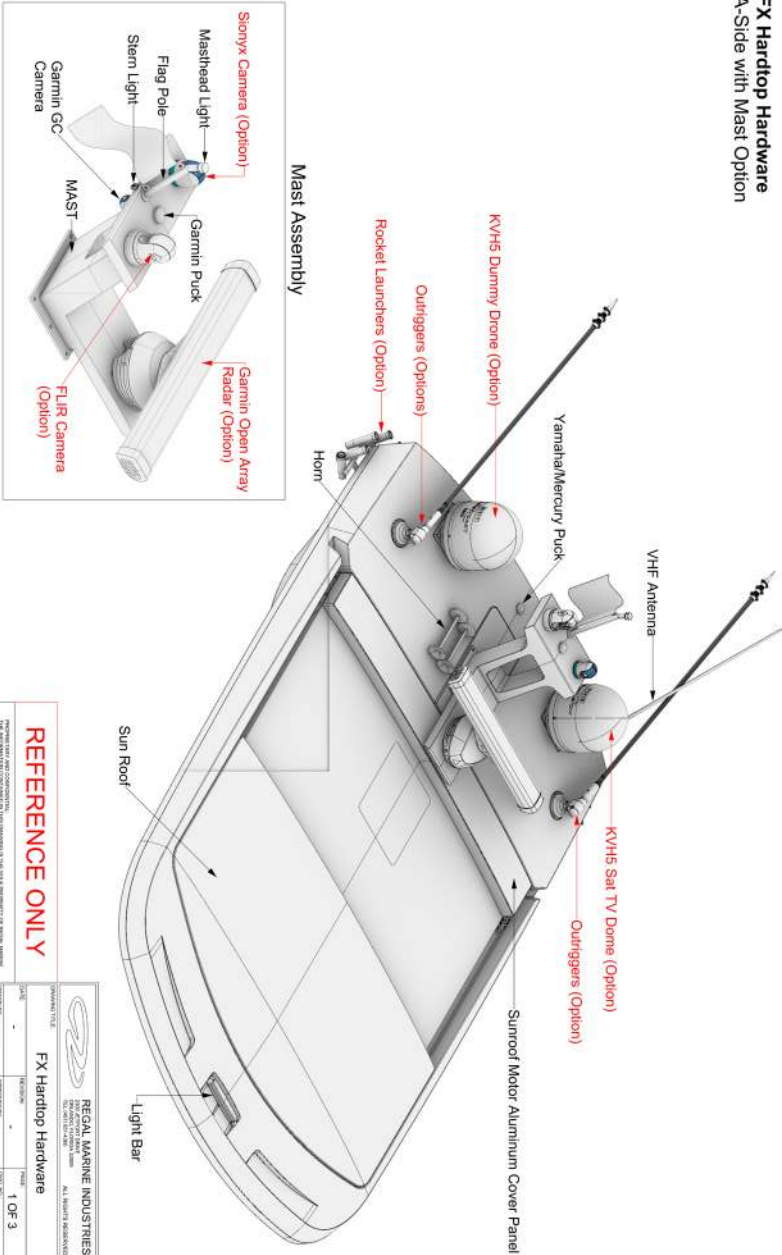

Hardtop Hardware - 3

Hardtop Sunroof brackets

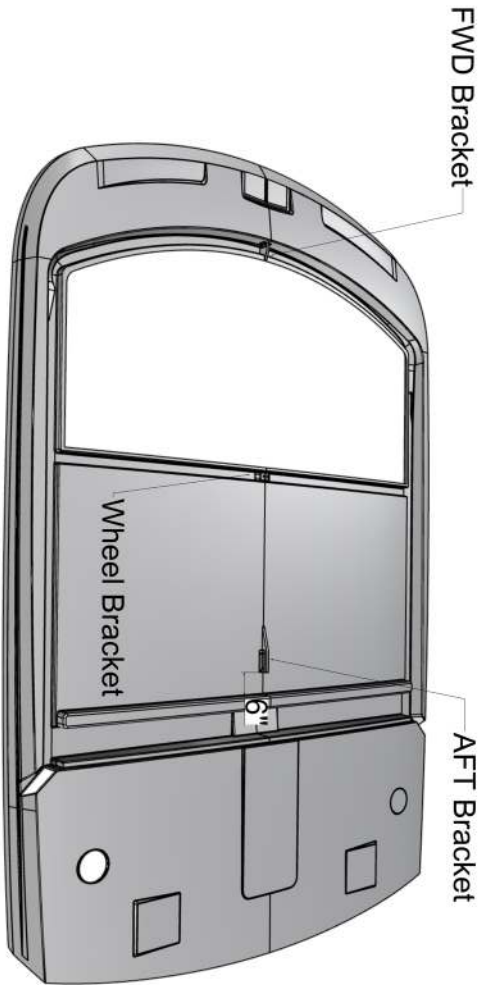

REFERENCE ONLY

REGAL MARINE AND INDUSTRIES, INC. MAKES NO WARRANTY, EXPRESS OR IMPLIED, AS TO THE ACCURACY, COMPLETENESS, OR RELIABILITY OF THE INFORMATION CONTAINED HEREIN. THE INFORMATION IS PROVIDED FOR REFERENCE ONLY AND IS NOT TO BE USED FOR ANY OTHER PURPOSE.

 <p>REGAL MARINE INDUSTRIES <small>REGAL MARINE INDUSTRIES, INC. 10000 W. 10th Street, Suite 100 Denver, CO 80231</small></p>		<p>ALL RIGHTS RESERVED</p>	
<p>ISSUE DATE: 8/8/2025</p>			
<p>PROJECT: FX Hardtop Hardware</p>			
<p>DATE: 8/8/2025</p>	<p>ISSUE: 1</p>	<p>REV: 0</p>	<p>REV: 0</p>
<p>PROJECT: SKV</p>	<p>ISSUE: 1</p>	<p>REV: 0</p>	<p>REV: 0</p>
<p>3 OF 3</p>		<p>100%</p>	

Sump Layout - LivePower

LX43 (FX) Sump Layout ALL OPTIONS

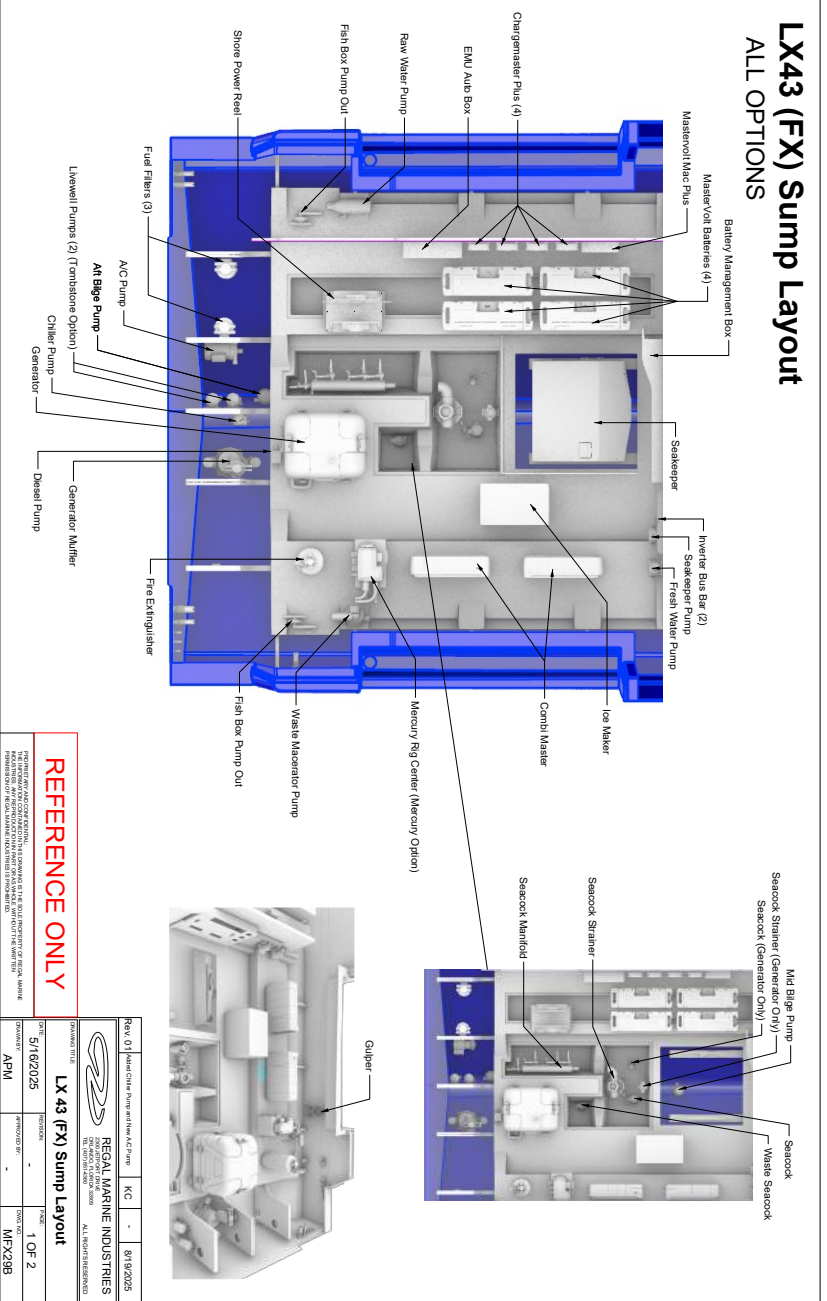

REFERENCE ONLY

THIS DRAWING AND ALL INFORMATION CONTAINED HEREIN IS THE SOLE PROPERTY OF REGAL MARINE. IT IS TO BE USED FOR THE EXCLUSIVE USE OF THE PROJECT AND IS NOT TO BE REPRODUCED, COPIED, OR TRANSMITTED IN ANY FORM OR BY ANY MEANS, ELECTRONIC OR MECHANICAL, INCLUDING PHOTOCOPYING, RECORDING, OR BY ANY INFORMATION STORAGE AND RETRIEVAL SYSTEM. PERMISSION TO COPY THIS DRAWING IS PROHIBITED.

Rev. 01 Final Client Pump and A/C Pumps	KC	-	3/19/2025
 REGAL MARINE INDUSTRIES 10000 Regal Drive Jacksonville, FL 32216 Tel: 904.731.1000			
PROJECT NO.	LX 43 (FX) Sump Layout	TITLE	1 OF 2
DATE	5/16/2025	DESIGNED BY	APM
APPROVED BY	-	PROJECT NO.	MF298

Sump Layout - Gen Only

LX43 (FX) Sump Layout Not Ice Maker or Mastervolt

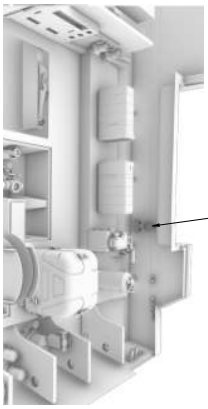
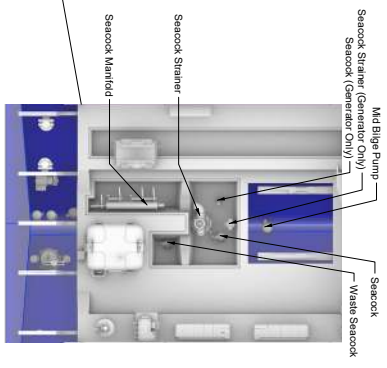
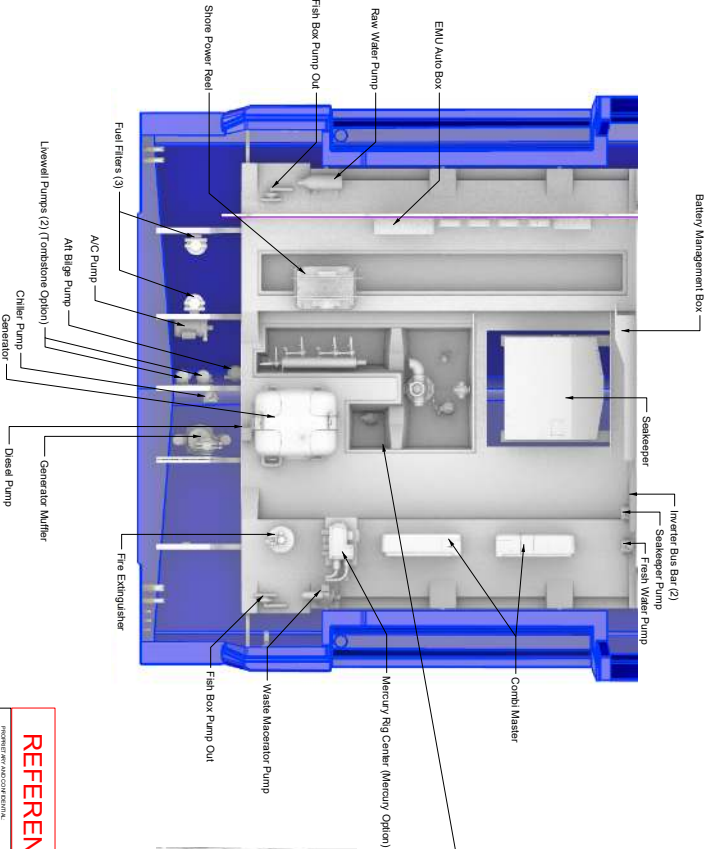

REFERENCE ONLY

FOR INFORMATION ONLY. THIS DRAWING IS THE PROPERTY OF REGAL MARINE INDUSTRIES. THE INFORMATION CONTAINED HEREIN IS THE PROPERTY OF REGAL MARINE INDUSTRIES. THE INFORMATION CONTAINED HEREIN IS THE PROPERTY OF REGAL MARINE INDUSTRIES. THE INFORMATION CONTAINED HEREIN IS THE PROPERTY OF REGAL MARINE INDUSTRIES.

Rev. 01	Revised Chiller Pump and Sea A/C Pump	KC	-	8/19/2025
 REGAL MARINE INDUSTRIES 2000 S.W. 11th Ave., Suite 200 Ft. Lauderdale, FL 33304 Tel: 954.771.0000 All Rights Reserved				
PROJECT TITLE	LX 43 (FX) Sump Layout			
DATE	5/11/6/2025	PROJECT NO.	-	PROJECT STATUS
OWNER	APM	DESIGNER	-	DATE
				2 OF 2
				MF-X298

Seacock Manifold - 1

FV/FX Seacock Manifold Routings
Sump Layout

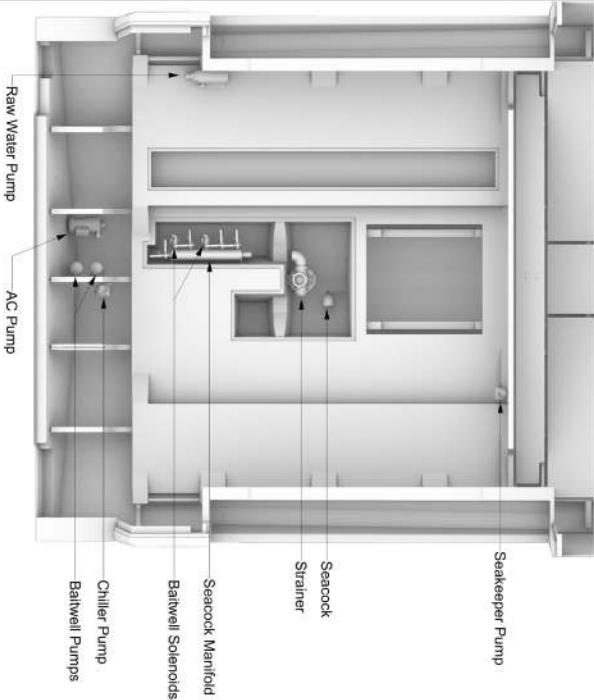

REFERENCE ONLY		<small>THIS INFORMATION IS FOR REFERENCE ONLY. THE INFORMATION IS NOT A CONTRACT AND IS SUBJECT TO CHANGE WITHOUT NOTICE. THE INFORMATION IS NOT A CONTRACT AND IS SUBJECT TO CHANGE WITHOUT NOTICE. THE INFORMATION IS NOT A CONTRACT AND IS SUBJECT TO CHANGE WITHOUT NOTICE.</small>	
 <p>REGAL MARINE INDUSTRIES 10000 W. 10th Street Tulsa, Oklahoma 74117</p>	<p>Part: 01 - Motor pumps and control wiring</p> <p>DS - 1</p> <p>DATE: 12/11/2024</p> <p>REV: 1 OF 2</p> <p>WCP</p>	<p>PROJECT: FV/FX Seacock Manifold Routings</p> <p>DATE: 12/11/2024</p> <p>REV: 1 OF 2</p> <p>WCP</p>	<p>DATE: 12/11/2024</p> <p>REV: 1 OF 2</p> <p>WCP</p>

NMEA 2000 Network

Subject Work Instruction: Yacht NMEA Network With Digital Switching Option	Issue Date: 09/02/2023	Rev: 0	Document No.: EL-253
Approved By: Paul Kuck	Written By: Kyle Quatman	Rev Date: -	Page: 1 of 1

Applies to Models: SA/SBS/ST/SX/SBS/VT/D/TF/TX/TXU/V/M/W/J/WK

+Volvo Glass Cockpit
+Yamaha Helm Master EX

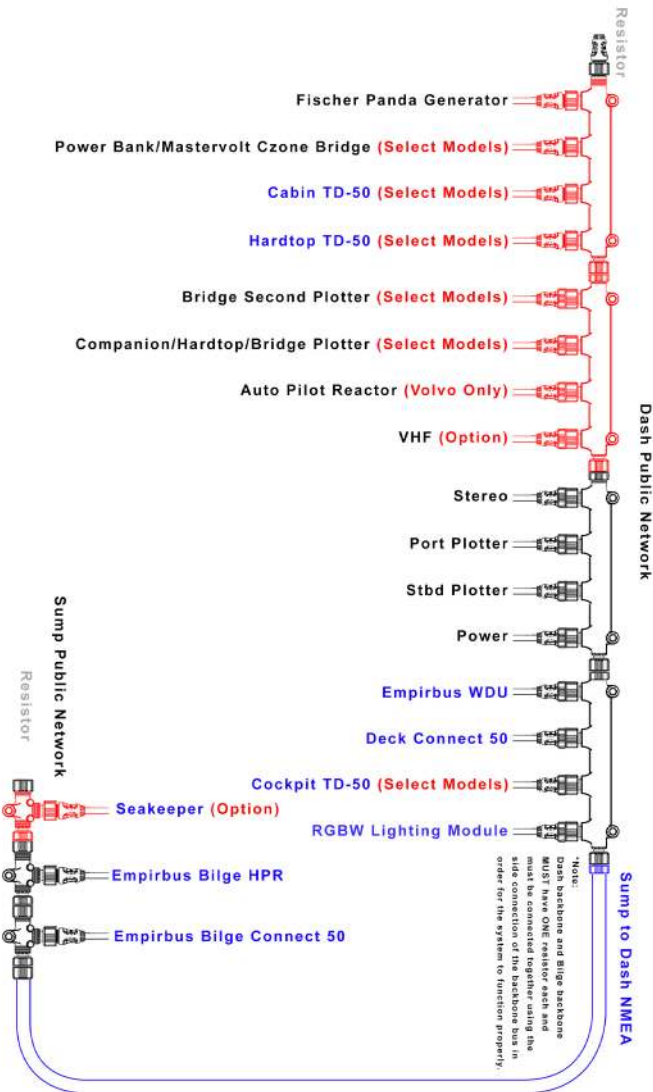

REFERENCE ONLY 1

Underwater Lights - EGIS

Subject Work Instruction: EGIS Underwater Lights Assembly EMU22UW	Issue Date: 10/18/2023	Rev: 1	Document No. EL-278
Approved By: Paul Kuck	Written By: Kyle Quatman	Rev Date: 2/20/2024	Page: 1 of 1

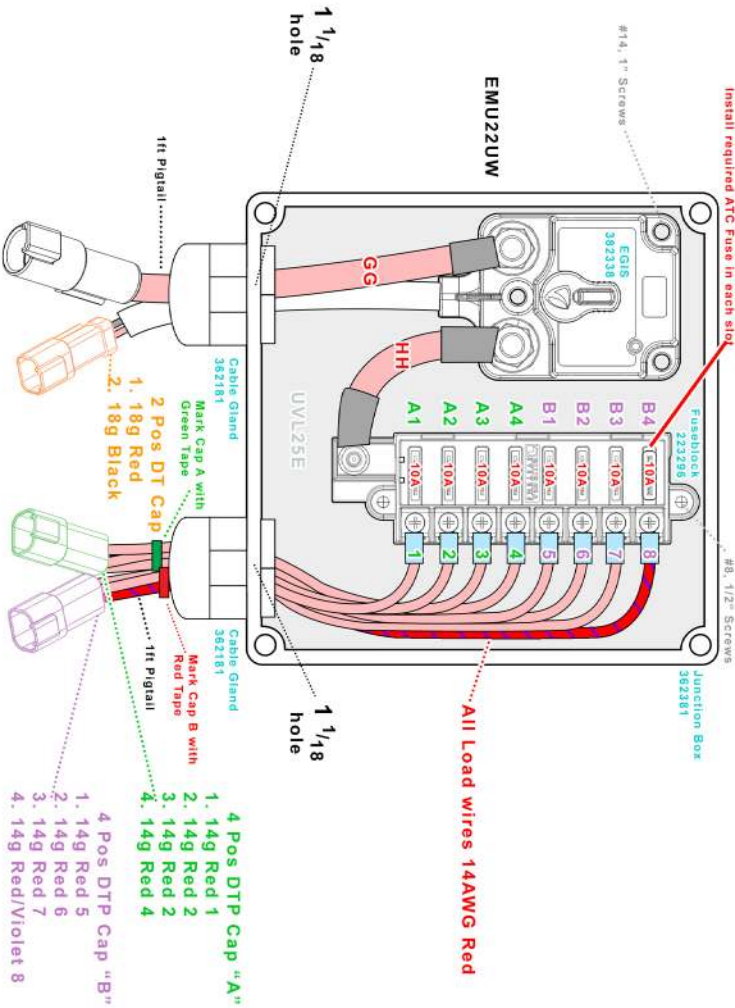

Underwater Lights Wiring

Subject Work Instructions: Ultimate Underwater Lights Package Wiring	Issue Date: 10/18/2023	Rev: 0	Document No. EL-277
Approved By: Paul Kock	Written By: Kyle Quaman	Rev Date:	Page: 1 of 1

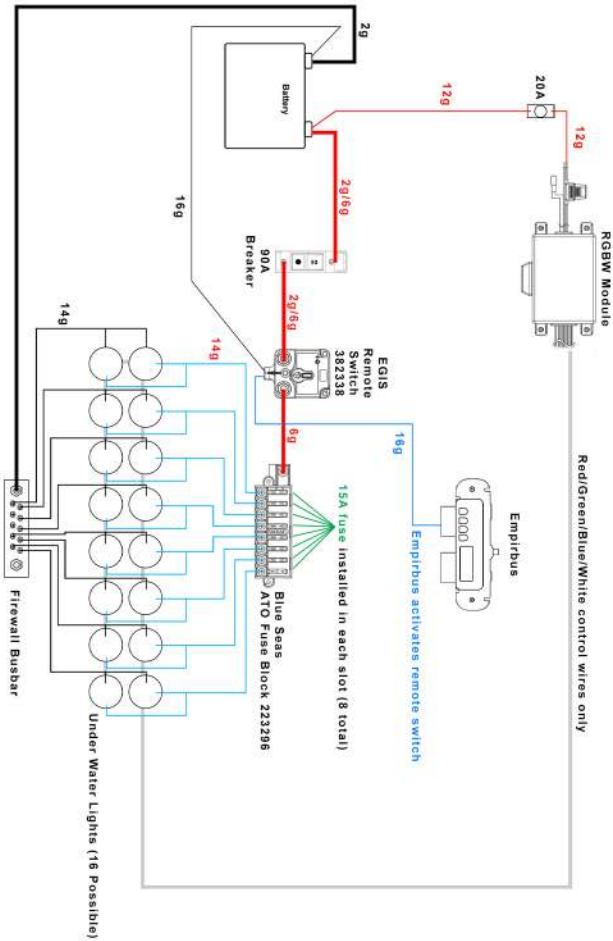

Battery Management Box - 2

Subject Work Instruction: Ultimate EGIS Battery Management Assembly	Issue Date: 01/13/2024	Rev: 2	Document No. EL-335
Approved By: Paul Kuck	Written By: Kyle Quatman	Rev Date: 5/13/2025	Page: 2 of 9

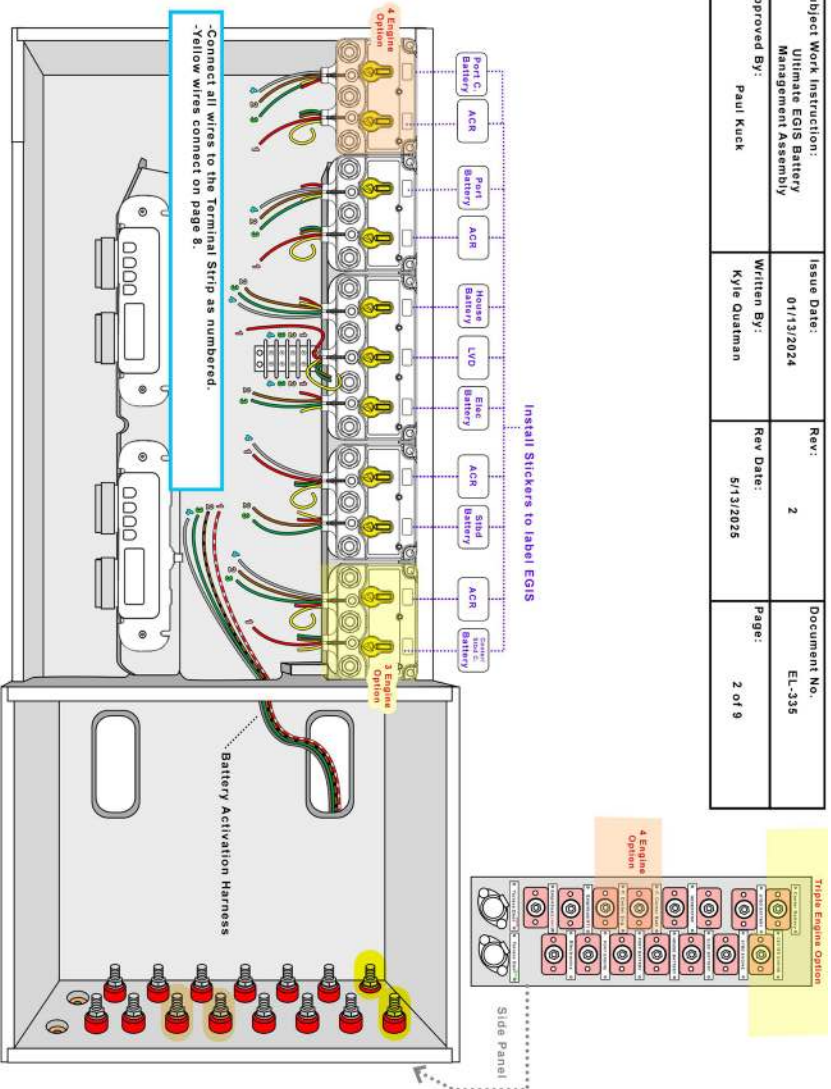

Battery Management Box - 3

Subject Work Instruction: Ultimate ECIS Battery Management Assembly	Issue Date: 01/13/2024	Rev.: 2	Document No.: EL-335
Approved By: Paul Kuck	Written By: Kyle Quatman	Rev Date: 5/13/2025	Page: 3 of 9

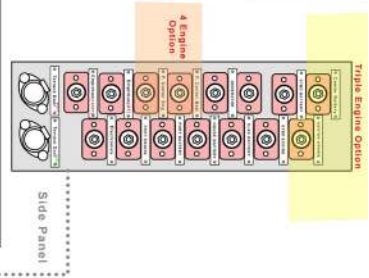
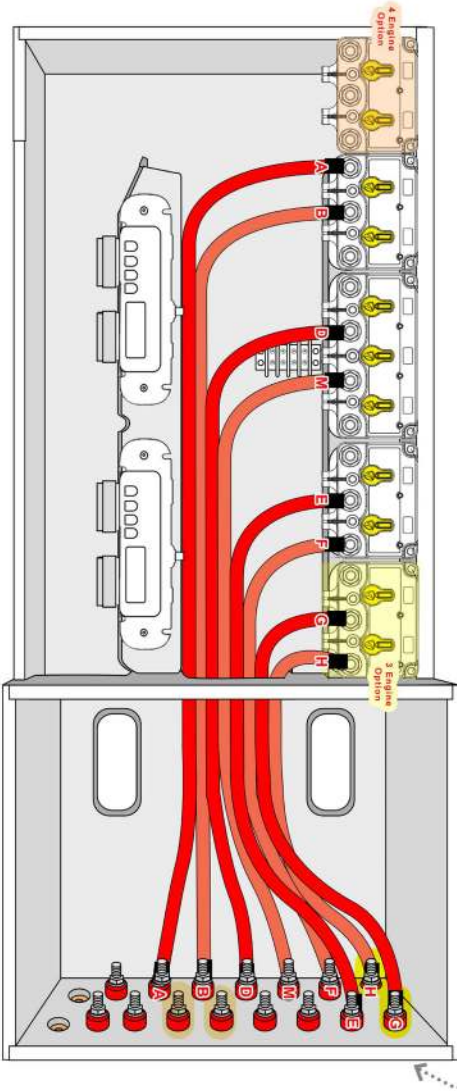

Battery Management Box - 4

Subject Work Instruction: Ultimate EGIS Battery Management Assembly	Issue Date: 01/13/2024	Rev: 2	Document No. EL-335
Approved By: Paul Kuck	Written By: Kyle Quaman	Rev Date: 5/13/2025	Page: 4 of 9

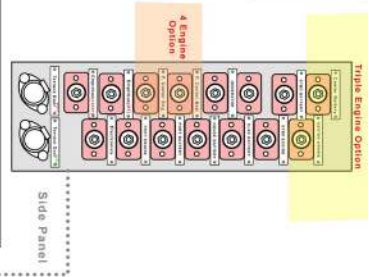
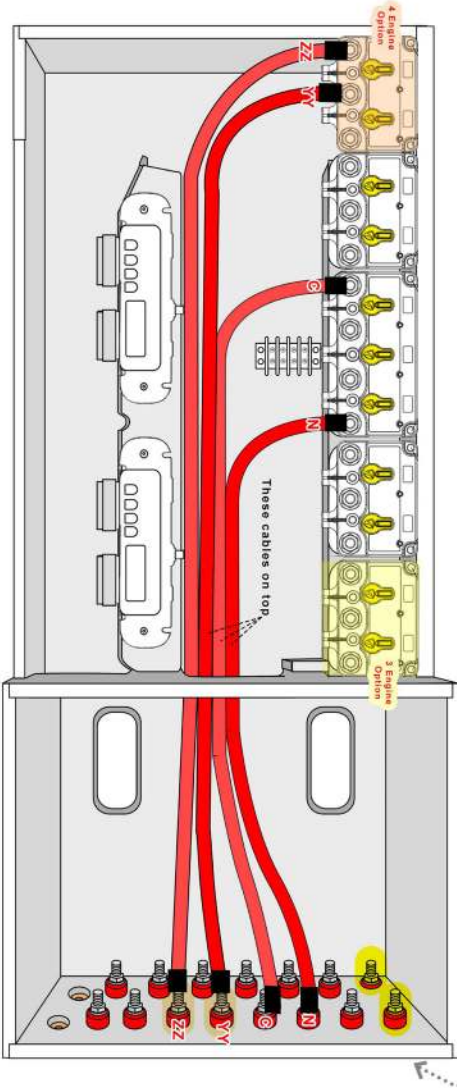

Battery Management Box - 5

Subject Work Instruction: Ultimate EGIS Battery Management Assembly	Issue Date: 01/13/2024	Rev.: 2	Document No.: EL-335
Approved By: Paul Kuck	Written By: Kyle Quatman	Rev Date: 5/13/2025	Page: 5 of 9

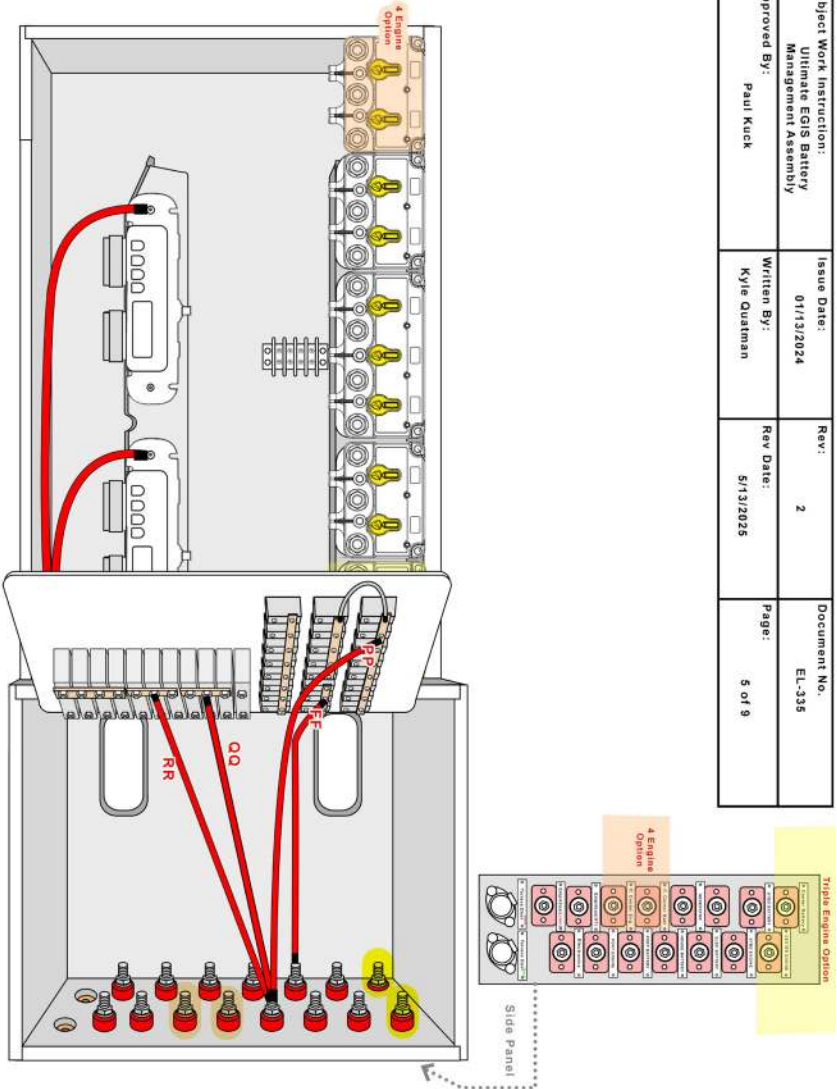

Battery Management Box - 6

Subject Work Instruction: Ultimate EGIS Battery Management Assembly	Issue Date: 01/13/2024	Rev: 2	Document No. EL-335
Approved By: Paul Kuck	Written By: Kyle Quatman	Rev Date: 5/13/2025	Page: 6 of 8

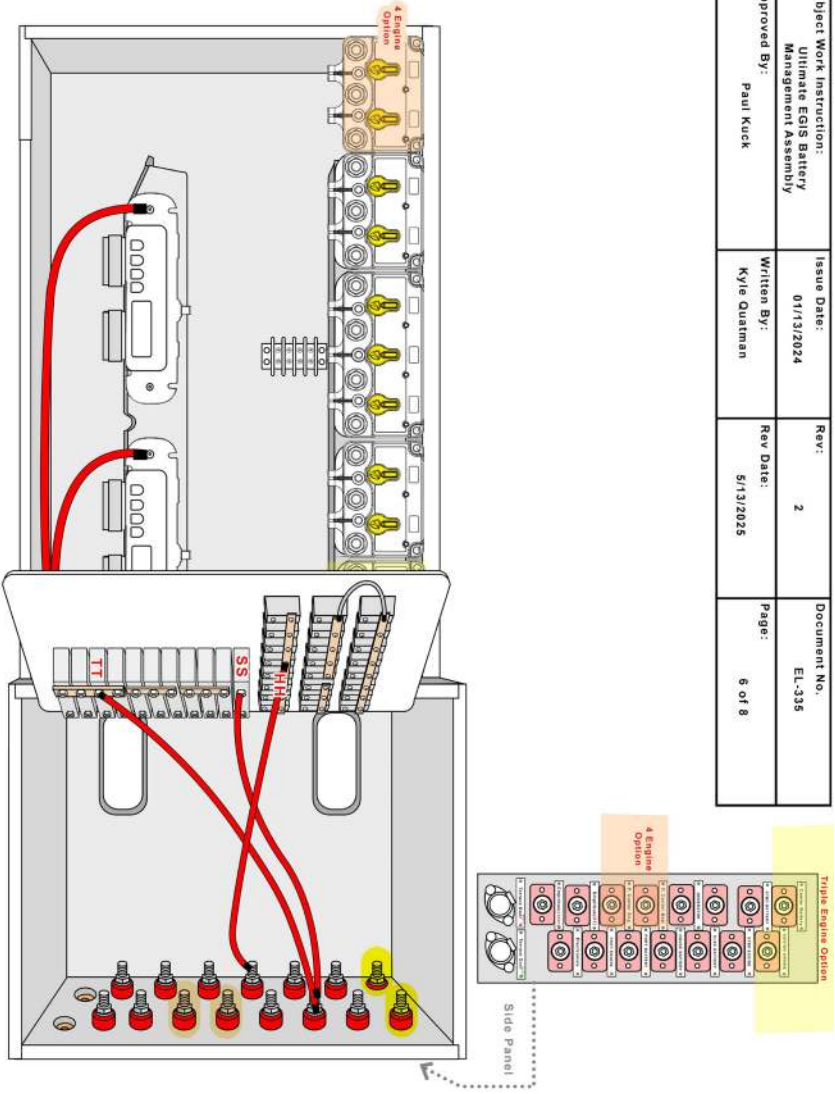

Battery Management Box - 7

Subject Work Instruction: Ultimate EGIS Battery Management Assembly	Issue Date: 01/13/2024	Rev: 2	Document No. EL-335
Approved By: Paul Kueck	Written By: Kyle Quatman	Rev Date: 5/13/2025	Page: 7 of 9

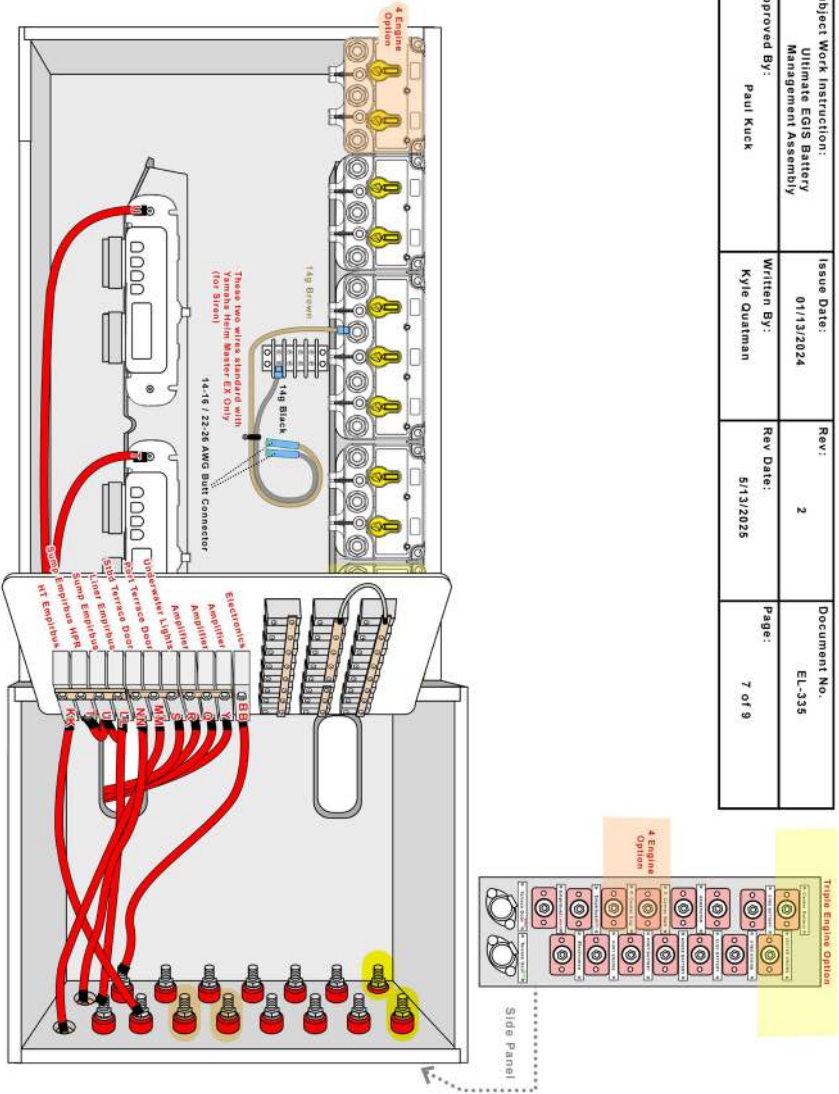

Battery Management Box - 8

Subject Work Instruction: Ultimate EGIS Battery Management Assembly	Issue Date: 01/13/2024	Rev: 2	Document No. EL-335
Approved By: Paul Kueck	Written By: Kyle Quatman	Rev Date: 5/13/2025	Page: 8 of 9

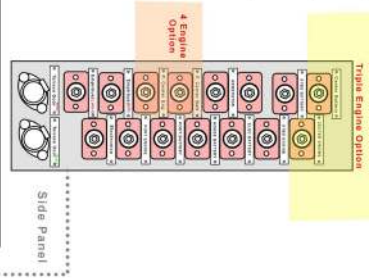
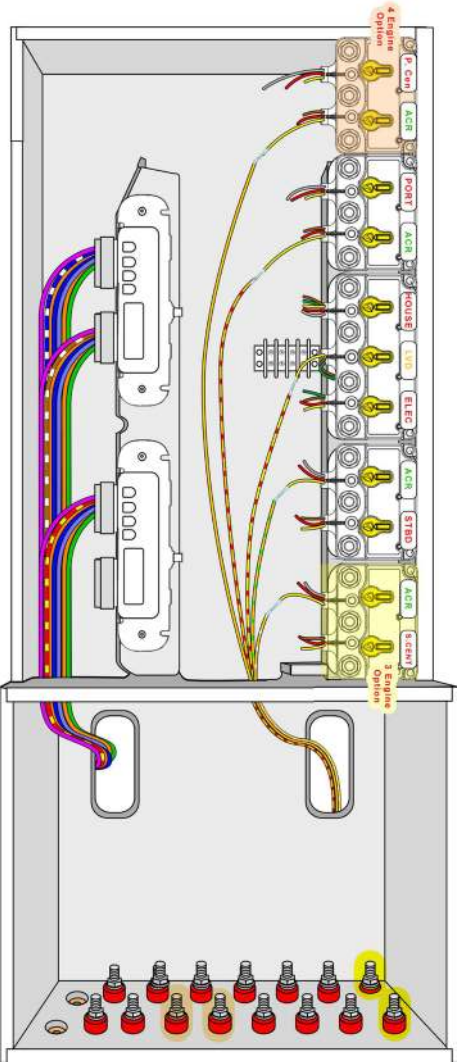

Battery Management Box - 9

Subject Work Instruction: Ultimate EGIS Battery Management Assembly	Issue Date: 01/13/2024	Rev: 2	Document No. EL-335
Approved By: Paul Kueck	Written By: Kyle Quatman	Rev Date: 5/13/2025	Page: 9 of 9

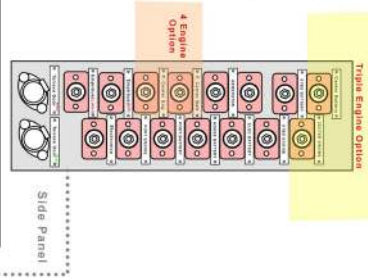
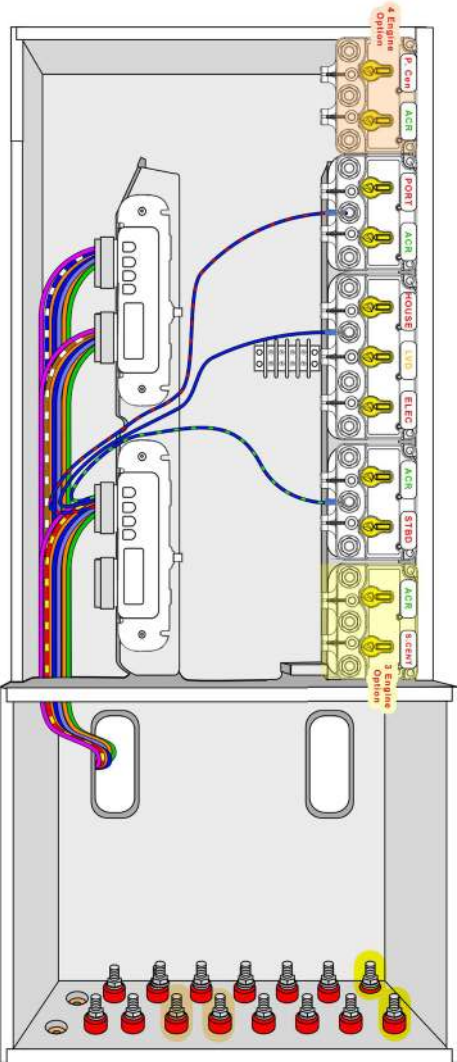

Battery Activation Panel

Subject Work Instruction:	Issue Date:	Rev:	Document No.
Battery Activation Panel Single Switch	10/18/2023	0	EL-274
Approved By:	Written By:	Rev Date:	Page:
Paul Kuck	Kyle Quatman	1 of 1

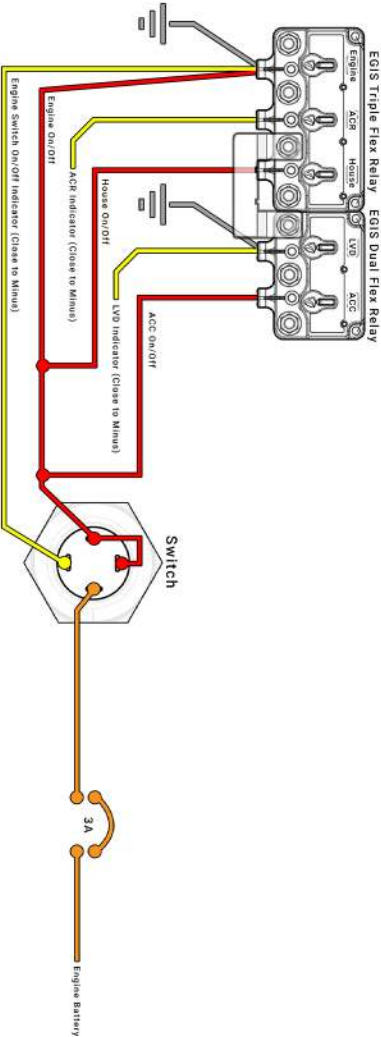
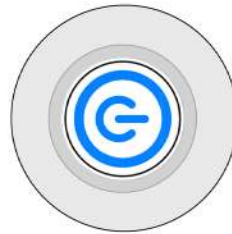

Harness Routings - 1

Subject Work Instruction: Ff, Fv, Fx Liner Harness Routings <i>Port Liner Harness</i>	Issue Date: 1/20/2025	Rev: 0	Document No. EL-338
Approved By: Paul Kuck	Written By: Pablo Gonzalez	Rev Date:	Page: 1 of 4

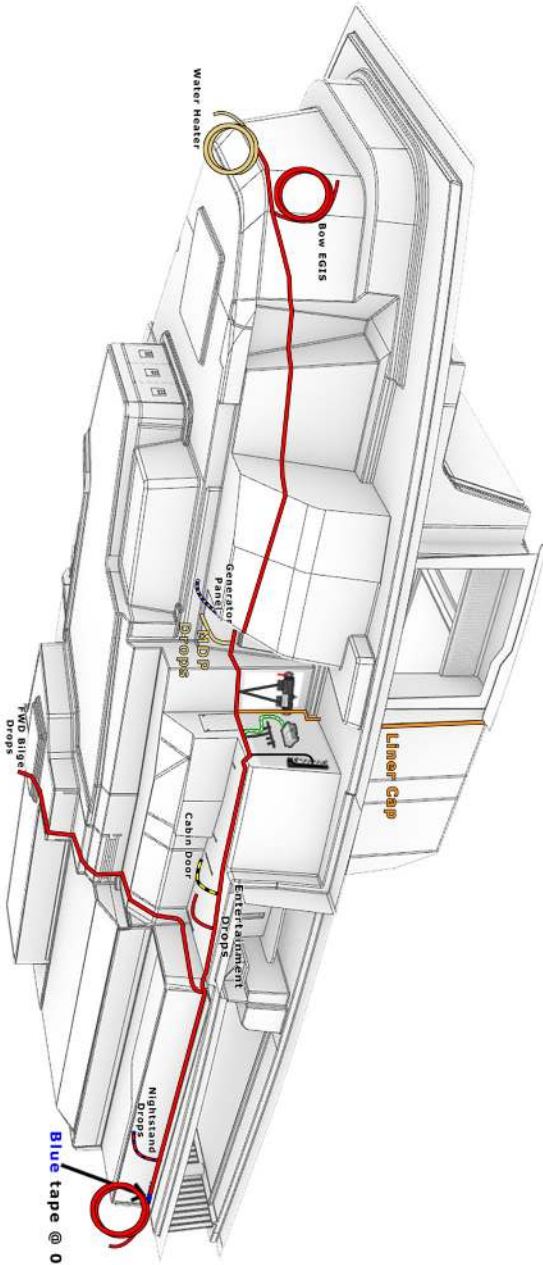

Harness Routings - 2

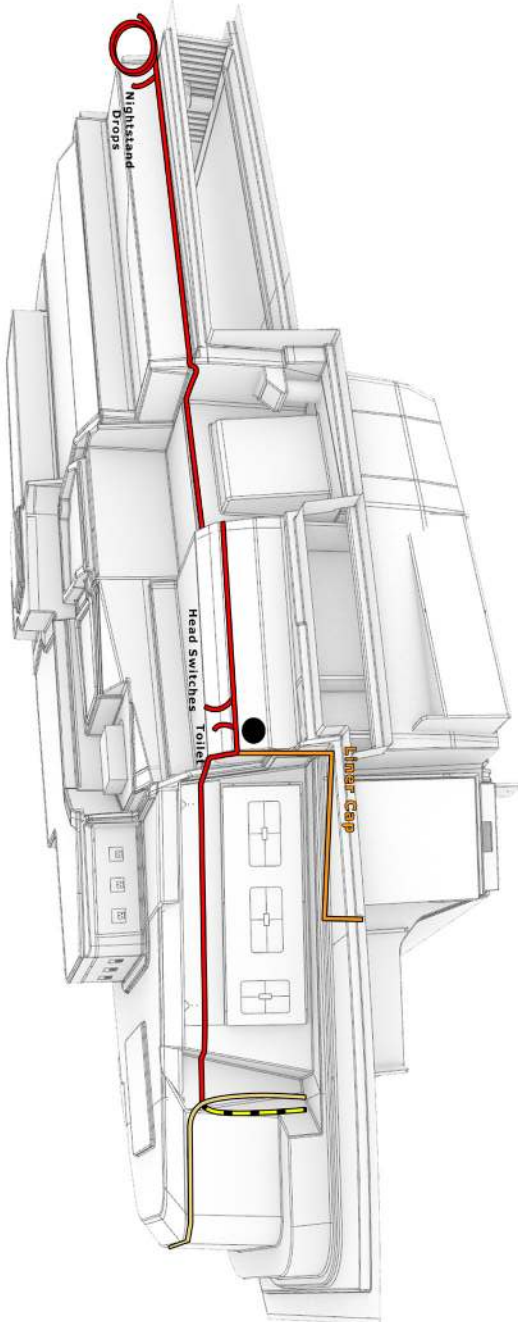

Subject Work Instruction: FF, FV SEIB Liner Harness Routings	Issue Date: 1/20/2025	Rev: 0	Document No. EL-336
Approved By: Paul Kuck	Written By: Pablo Gonzalez	Rev Date:	Page: 2 of 4

Harness Routings - 3

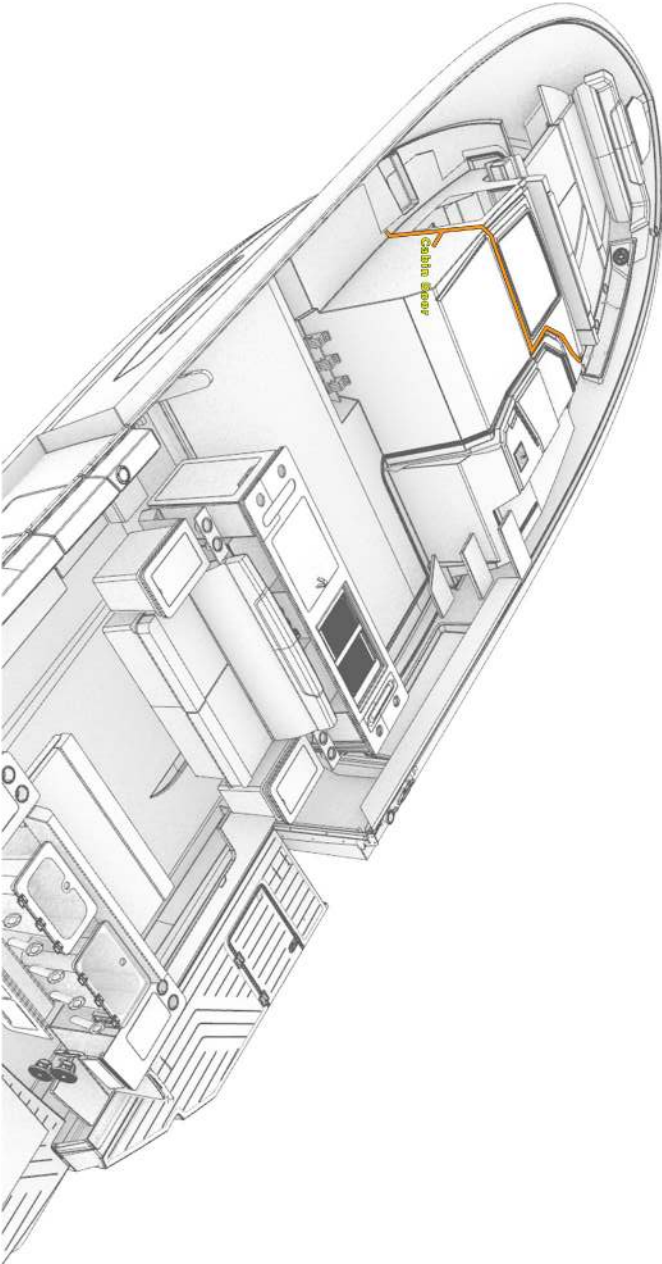

Subject Work Instruction: FF, FV, FX Liner Harness Routings	Issue Date: 1/20/2025	Rev: 0	Document No. EL-338
Approved By: Paul Kuck	Written By: Pablo Gonzalez	Rev Date:	Page: 3 of 4

Harness Routings - 4

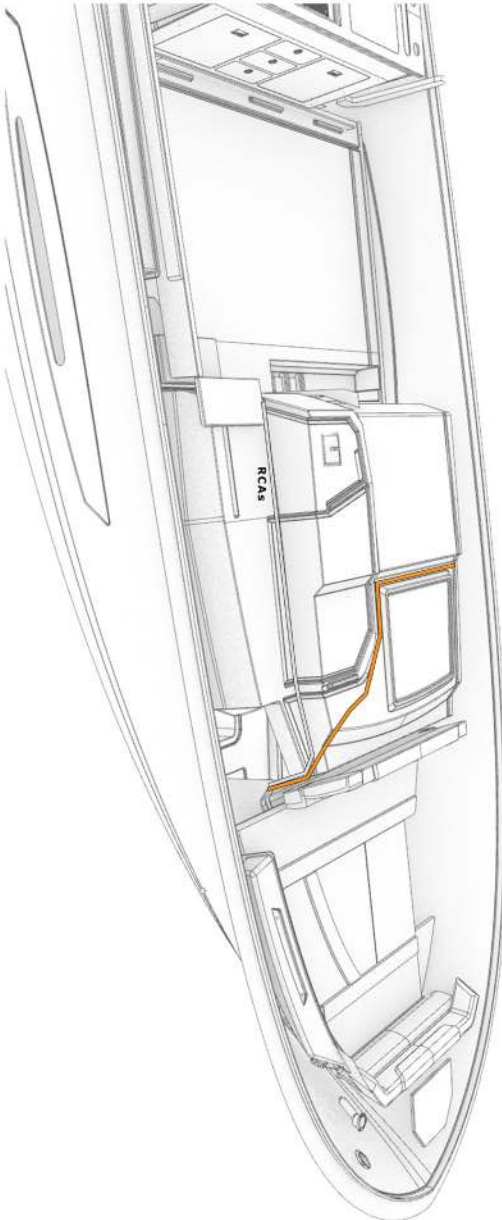

Subject Work Instruction: FF, FV, FX Liner Harness Routings	Issue Date: 1/20/2025	Rev: 0	Document No. EL-338
Approved By: Paul Kuck	Written By: Pablo Gonzalez	Rev Date:	Page: 4 of 4

Harness Routings - 6

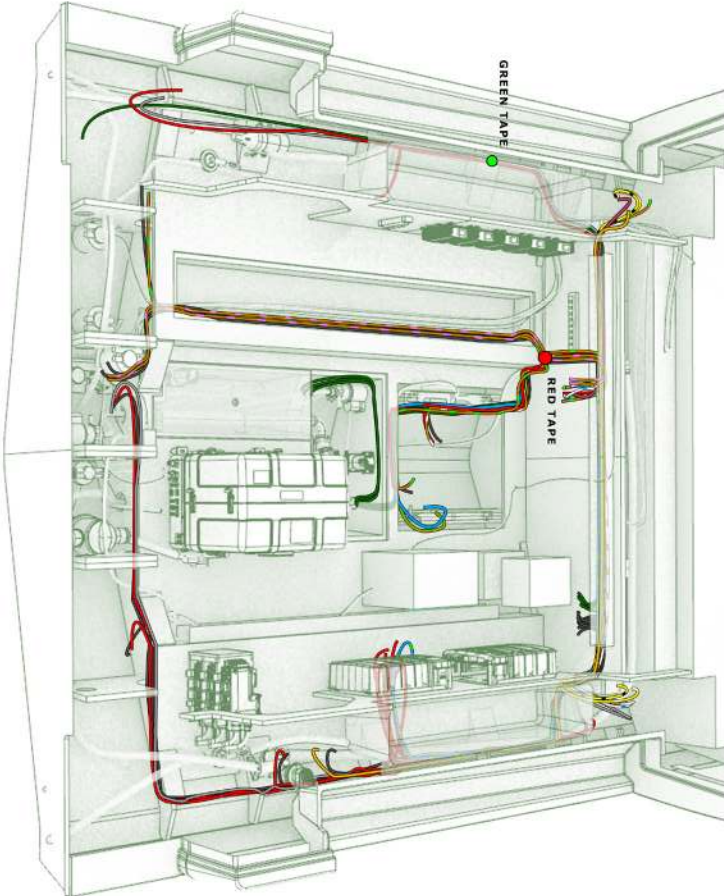

Subject Work Instruction: #1, #2, #3, #4, #5, #6, #7, #8, #9, #10, #11, #12, #13, #14, #15, #16, #17, #18, #19, #20, #21, #22, #23, #24, #25, #26, #27, #28, #29, #30, #31, #32, #33, #34, #35, #36, #37, #38, #39, #40, #41, #42, #43, #44, #45, #46, #47, #48, #49, #50, #51, #52, #53, #54, #55, #56, #57, #58, #59, #60, #61, #62, #63, #64, #65, #66, #67, #68, #69, #70, #71, #72, #73, #74, #75, #76, #77, #78, #79, #80, #81, #82, #83, #84, #85, #86, #87, #88, #89, #90, #91, #92, #93, #94, #95, #96, #97, #98, #99, #100, #101, #102, #103, #104, #105, #106, #107, #108, #109, #110, #111, #112, #113, #114, #115, #116, #117, #118, #119, #120, #121, #122, #123, #124, #125, #126, #127, #128, #129, #130, #131, #132, #133, #134, #135, #136, #137, #138, #139, #140, #141, #142, #143, #144, #145, #146, #147, #148, #149, #150, #151, #152, #153, #154, #155, #156, #157, #158, #159, #160, #161, #162, #163, #164, #165, #166, #167, #168, #169, #170, #171, #172, #173, #174, #175, #176, #177, #178, #179, #180, #181, #182, #183, #184, #185, #186, #187, #188, #189, #190, #191, #192, #193, #194, #195, #196, #197, #198, #199, #200, #201, #202, #203, #204, #205, #206, #207, #208, #209, #210, #211, #212, #213, #214, #215, #216, #217, #218, #219, #220, #221, #222, #223, #224, #225, #226, #227, #228, #229, #230, #231, #232, #233, #234, #235, #236, #237, #238, #239, #240, #241, #242, #243, #244, #245, #246, #247, #248, #249, #250, #251, #252, #253, #254, #255, #256, #257, #258, #259, #260, #261, #262, #263, #264, #265, #266, #267, #268, #269, #270, #271, #272, #273, #274, #275, #276, #277, #278, #279, #280, #281, #282, #283, #284, #285, #286, #287, #288, #289, #290, #291, #292, #293, #294, #295, #296, #297, #298, #299, #300, #301, #302, #303, #304, #305, #306, #307, #308, #309, #310, #311, #312, #313, #314, #315, #316, #317, #318, #319, #320, #321, #322, #323, #324, #325, #326, #327, #328, #329, #330, #331, #332, #333, #334, #335, #336, #337, #338, #339, #340, #341, #342, #343, #344, #345, #346, #347, #348, #349, #350, #351, #352, #353, #354, #355, #356, #357, #358, #359, #360, #361, #362, #363, #364, #365, #366, #367, #368, #369, #370, #371, #372, #373, #374, #375, #376, #377, #378, #379, #380, #381, #382, #383, #384, #385, #386, #387, #388, #389, #390, #391, #392, #393, #394, #395, #396, #397, #398, #399, #400, #401, #402, #403, #404, #405, #406, #407, #408, #409, #410, #411, #412, #413, #414, #415, #416, #417, #418, #419, #420, #421, #422, #423, #424, #425, #426, #427, #428, #429, #430, #431, #432, #433, #434, #435, #436, #437, #438, #439, #440, #441, #442, #443, #444, #445, #446, #447, #448, #449, #450, #451, #452, #453, #454, #455, #456, #457, #458, #459, #460, #461, #462, #463, #464, #465, #466, #467, #468, #469, #470, #471, #472, #473, #474, #475, #476, #477, #478, #479, #480, #481, #482, #483, #484, #485, #486, #487, #488, #489, #490, #491, #492, #493, #494, #495, #496, #497, #498, #499, #500, #501, #502, #503, #504, #505, #506, #507, #508, #509, #510, #511, #512, #513, #514, #515, #516, #517, #518, #519, #520, #521, #522, #523, #524, #525, #526, #527, #528, #529, #530, #531, #532, #533, #534, #535, #536, #537, #538, #539, #540, #541, #542, #543, #544, #545, #546, #547, #548, #549, #550, #551, #552, #553, #554, #555, #556, #557, #558, #559, #560, #561, #562, #563, #564, #565, #566, #567, #568, #569, #570, #571, #572, #573, #574, #575, #576, #577, #578, #579, #580, #581, #582, #583, #584, #585, #586, #587, #588, #589, #590, #591, #592, #593, #594, #595, #596, #597, #598, #599, #600, #601, #602, #603, #604, #605, #606, #607, #608, #609, #610, #611, #612, #613, #614, #615, #616, #617, #618, #619, #620, #621, #622, #623, #624, #625, #626, #627, #628, #629, #630, #631, #632, #633, #634, #635, #636, #637, #638, #639, #640, #641, #642, #643, #644, #645, #646, #647, #648, #649, #650, #651, #652, #653, #654, #655, #656, #657, #658, #659, #660, #661, #662, #663, #664, #665, #666, #667, #668, #669, #670, #671, #672, #673, #674, #675, #676, #677, #678, #679, #680, #681, #682, #683, #684, #685, #686, #687, #688, #689, #690, #691, #692, #693, #694, #695, #696, #697, #698, #699, #700, #701, #702, #703, #704, #705, #706, #707, #708, #709, #710, #711, #712, #713, #714, #715, #716, #717, #718, #719, #720, #721, #722, #723, #724, #725, #726, #727, #728, #729, #730, #731, #732, #733, #734, #735, #736, #737, #738, #739, #740, #741, #742, #743, #744, #745, #746, #747, #748, #749, #750, #751, #752, #753, #754, #755, #756, #757, #758, #759, #760, #761, #762, #763, #764, #765, #766, #767, #768, #769, #770, #771, #772, #773, #774, #775, #776, #777, #778, #779, #780, #781, #782, #783, #784, #785, #786, #787, #788, #789, #790, #791, #792, #793, #794, #795, #796, #797, #798, #799, #800, #801, #802, #803, #804, #805, #806, #807, #808, #809, #810, #811, #812, #813, #814, #815, #816, #817, #818, #819, #820, #821, #822, #823, #824, #825, #826, #827, #828, #829, #830, #831, #832, #833, #834, #835, #836, #837, #838, #839, #840, #841, #842, #843, #844, #845, #846, #847, #848, #849, #850, #851, #852, #853, #854, #855, #856, #857, #858, #859, #860, #861, #862, #863, #864, #865, #866, #867, #868, #869, #870, #871, #872, #873, #874, #875, #876, #877, #878, #879, #880, #881, #882, #883, #884, #885, #886, #887, #888, #889, #890, #891, #892, #893, #894, #895, #896, #897, #898, #899, #900, #901, #902, #903, #904, #905, #906, #907, #908, #909, #910, #911, #912, #913, #914, #915, #916, #917, #918, #919, #920, #921, #922, #923, #924, #925, #926, #927, #928, #929, #930, #931, #932, #933, #934, #935, #936, #937, #938, #939, #940, #941, #942, #943, #944, #945, #946, #947, #948, #949, #950, #951, #952, #953, #954, #955, #956, #957, #958, #959, #960, #961, #962, #963, #964, #965, #966, #967, #968, #969, #970, #971, #972, #973, #974, #975, #976, #977, #978, #979, #980, #981, #982, #983, #984, #985, #986, #987, #988, #989, #990, #991, #992, #993, #994, #995, #996, #997, #998, #999, #1000	Issue Date: 01/12/2025	Rev: 5	Document No. EL-139
Approved By: Paul Keck	Written By: Kyle Quastman	Rev Date: ..	Page: ..

Harness Routings - 7

Subject Work Instruction: FFV/FX Ultra Lounge Harness Routing	Issue Date: 4/28/2025	Rev.: 0	Document No. EL-345
Approved By: Paul Kuck	Written By: Pablo Gonzalez	Rev Date: ..	Page:

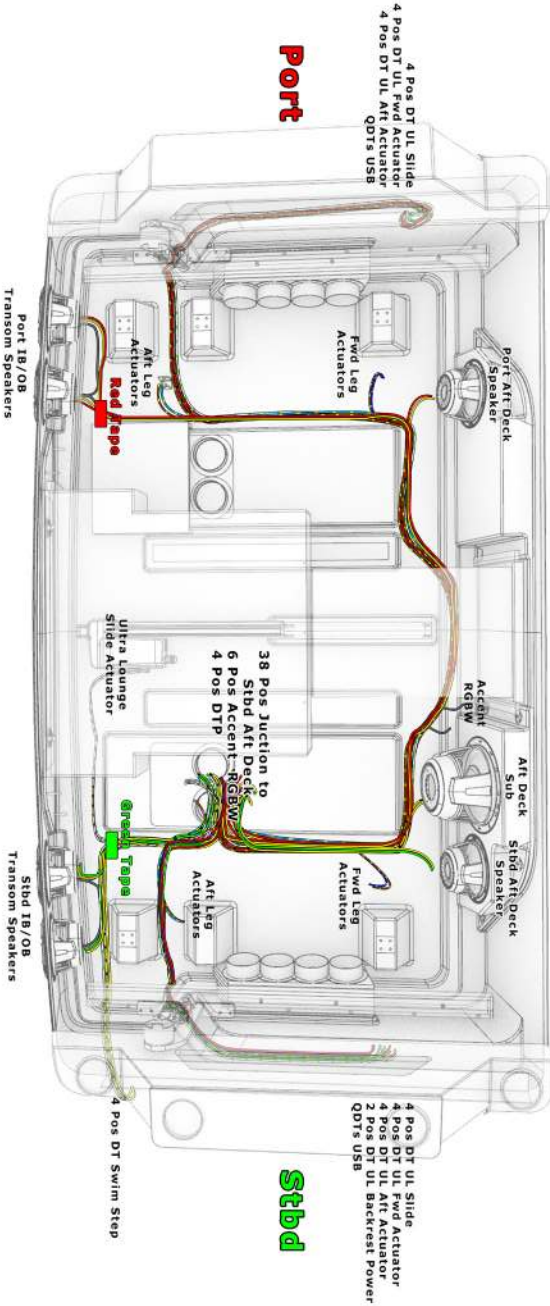

Digital Switching - Windlass

Subject Work Instruction: Digital Switching Windlass Wiring Config Rev 2.0	Issue Date: 12/21/2021	Rev: 1	Document No. EI-211
Approved By: Dion Colbourne	Written By: Kyle Qualman	Rev Date: 02/17/2023	Page: 1 of 1

I REFERENCE ONLY I

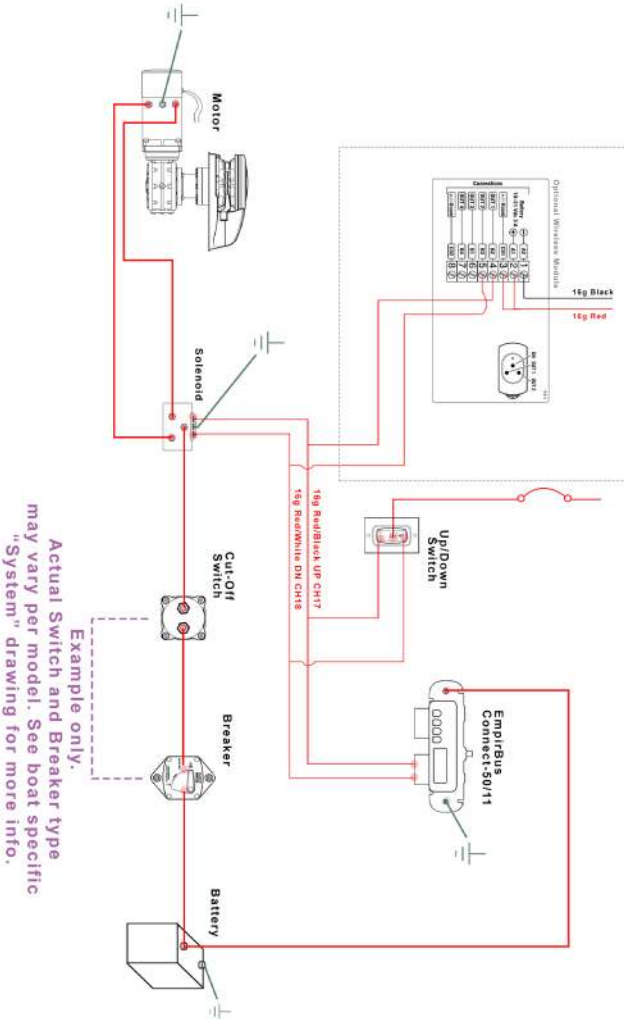

Galvanic Isolator

Subject Work Instruction: 120240 VAC Galvanic Grounding	Issue Date: 02/28/2023	Rev: 0	Document No. EL-350
Approved By: Paul Kuck	Written By: Kyle Quisman	Rev Date:	Page: 7 of 8

Shore Cord Reel w/ Galvanic Isolator at ELCI

REFERENCE ONLY 1

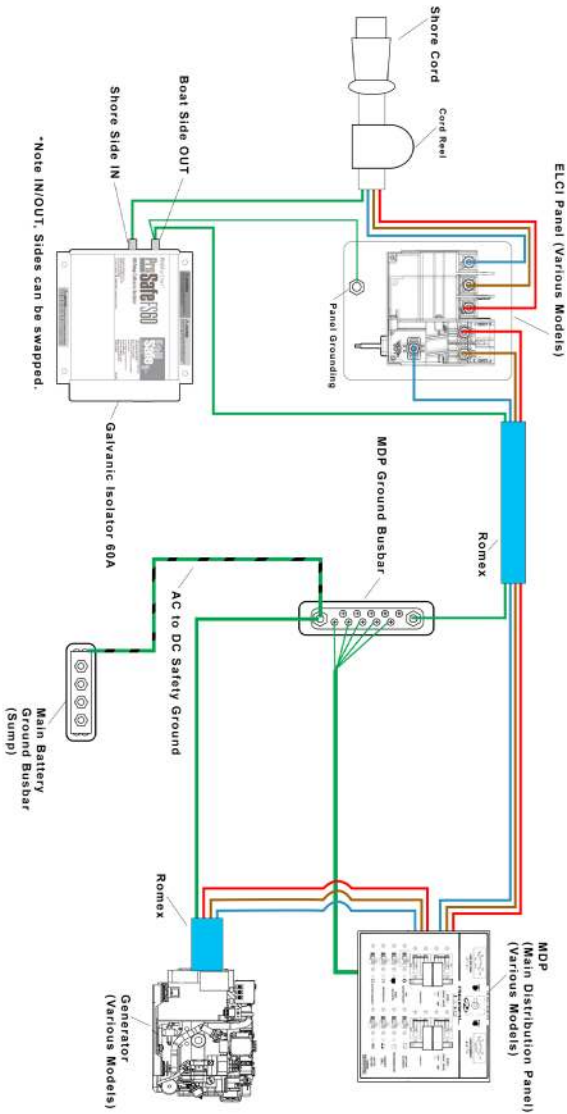

Yamaha Helm Master EX - 1

Subject Work Instruction: Helm Master EX Harnesses	Issue Date: 06/02/2021	Rev: 0	Document No. EL-191
Approved By: Dion Colbourne	Written By: Kylie Quatman	Rev Date: ----	Page: 1 of 3

[REFERENCE ONLY]

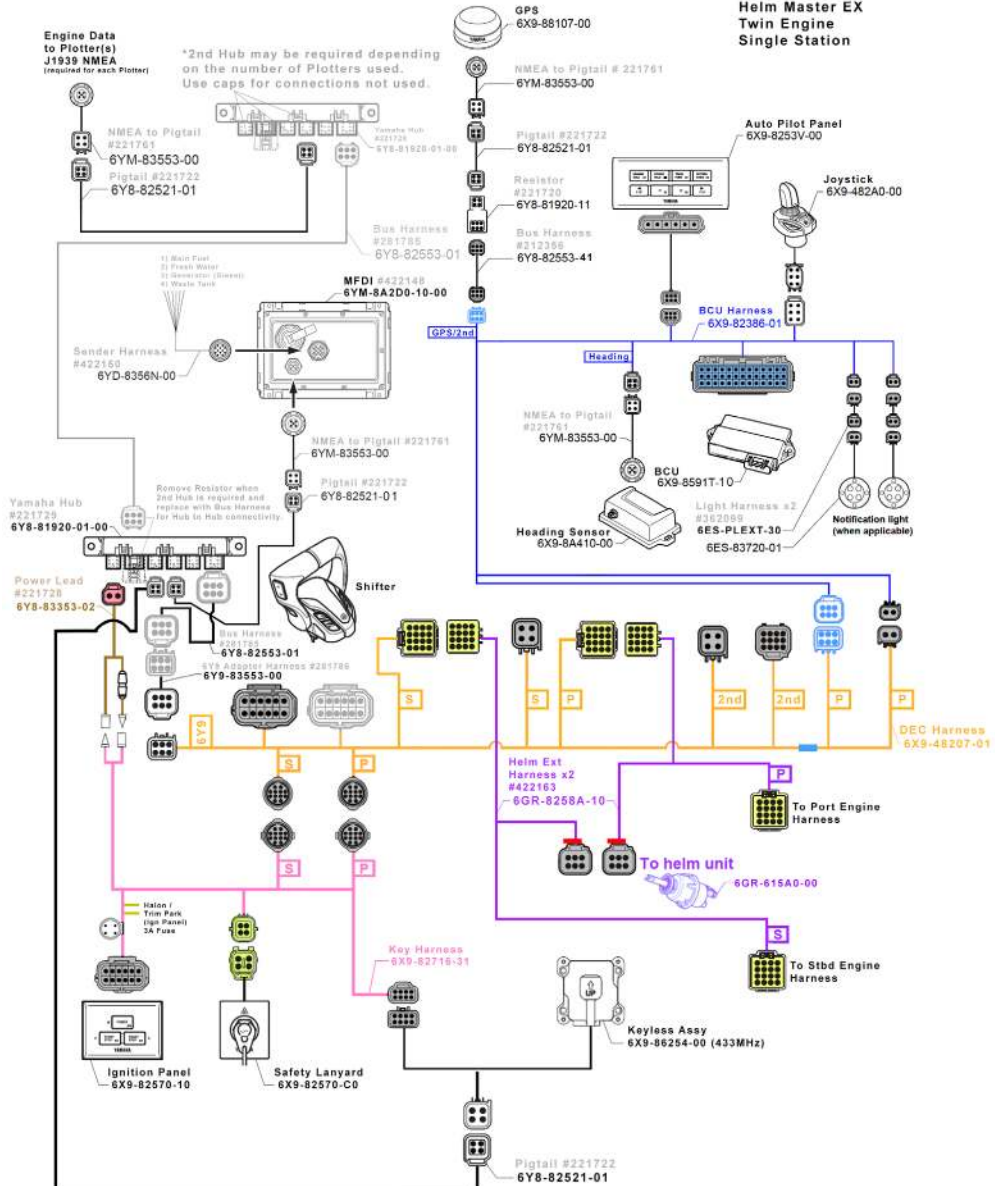

Grill/Stove Limit Switch

Subject Work Instruction: Grill/Stove Limit Switch Activation Box Assembly	Issue Date: 10/12/2020	Rev: 2	Document No. WS-1641
Approved By: Dion Colbourne	Written By: Kyle Quatman	Rev Date: 04/22/2025	Page:

[REFERENCE ONLY]

120V Domestic + 230V International

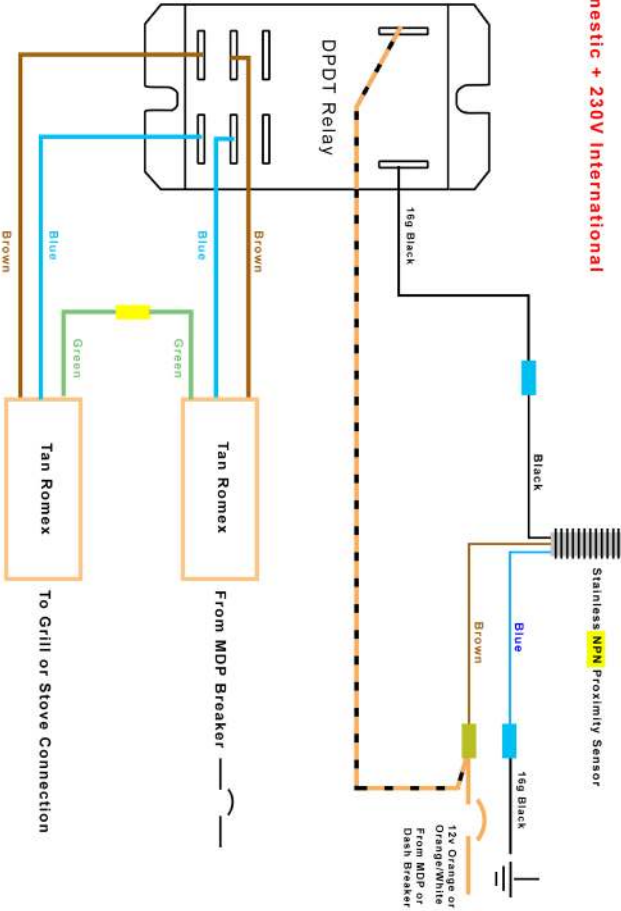

Diesel Shutdown

Subject Work Instruction: Diesel Shutdown Module Diesel Generator w/ Gas Engines Dion Colbourne	Issue Date: 07/29/2020	Rev: 0	Document No. EL-144
Approved By: Dion Colbourne	Written By: Kyle Quzman	Rev Date:	Page: 1 of 1

[REFERENCE ONLY]

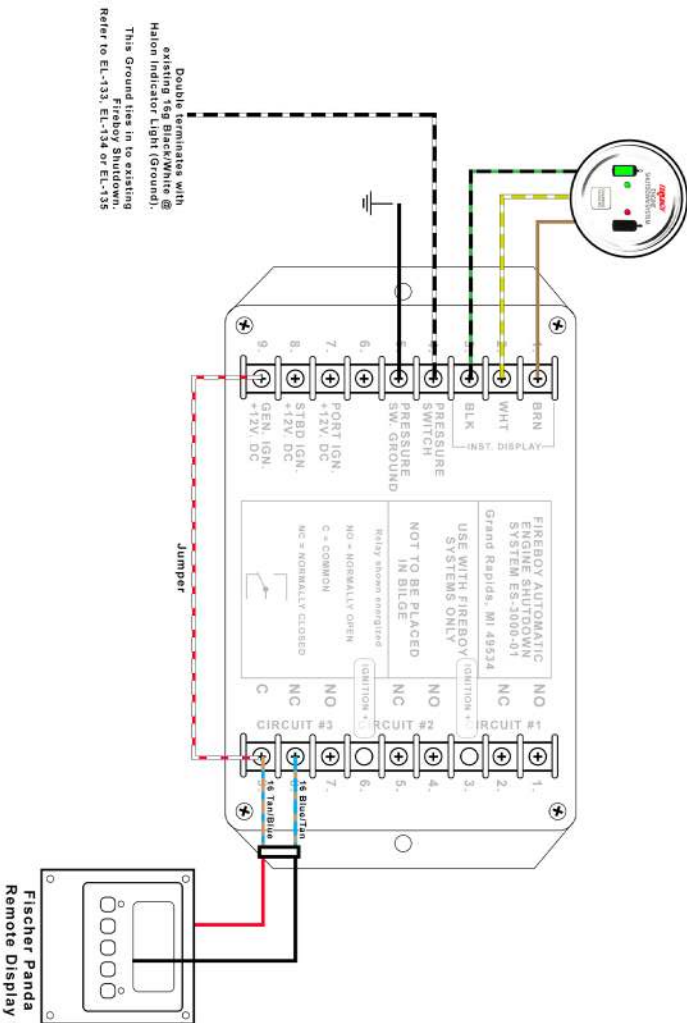

Fireboy System

Subject Work Instruction: Fireboy System w/ Fischer Panda Gen Digital Switching	Issue Date: 10/12/2021	Rev: -	Document No. EL-273
Approved By: Paul Kuck	Written By: Kyle Quatman	Rev. Date: -	Page: 1 of 1

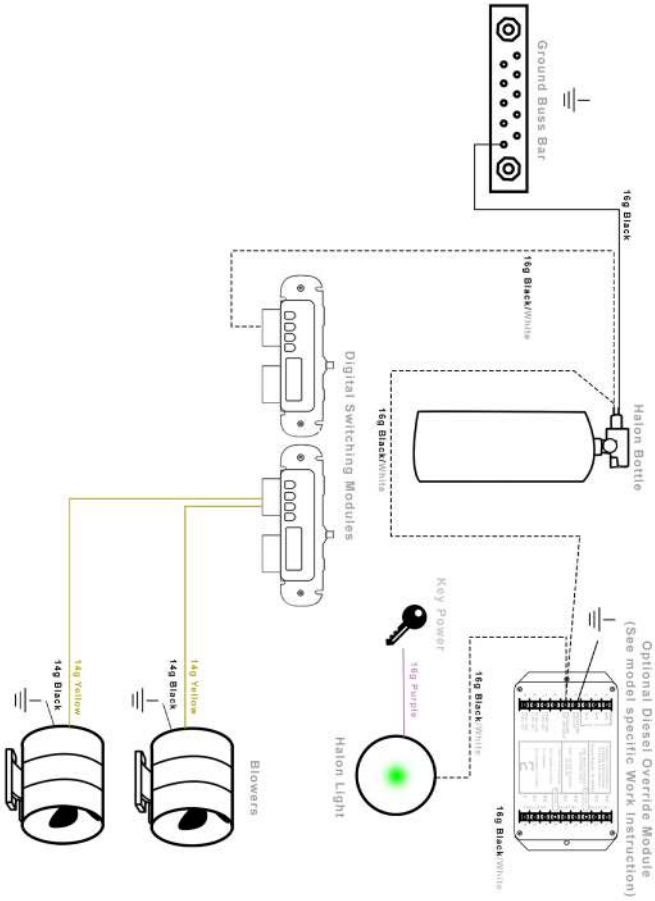

Index

A

- AC Main Distribution Panel (MDP) - 119, 154
- Acrylic Care - 195
- Air Conditioning - 118, 189
- Anchor Locker - 82
- Auto-Transfer Box - 140

B

- Baitwells - 164, 188
- Battery activation panel - 87, 138
- Battery management box - 153
- Batteries - 148
- Bilge pumps - 160, 188
- Boarding steps - 73
- Bow battery - 121, 149
- Bow SunShade - 85
- Bow thruster - 121, 149, 162
- Breaker reset - 172
- Breakers - 152

C

- Cabin door - 115, 166
- Cabin TV - 126
- Canvas care - 195
- Carbon monoxide (CO) - 128, 193
- Chartplotters - 157
- Chill Cool Vinyl care - 199
- Chiller tub - 106, 165
- Cockpit TV - 113, 167
- Convertible transom seat option - 64, 70
- Cooling (Engine) - 133

D

- DC batteries - 148
- Deployable transom ladder - 65
- Digital Switching System (DSS) - 160
- Dive door - 73
- DSS: Backend menu - 169
- DSS: Cabin - 168
- DSS: Deck - 163
- DSS: Hardtop - 167
- DSS: Troubleshooting - 172

E

- EGIS modules - 156
- ELCI - 67, 147
- Empirbus - 170
- Engine batteries - 121, 148
- Engine flush - 161
- Exhaust (Engine) - 133

F

- Fender clips - 68
- Fiberglass care - 196
- Fire suppression (Auto and Manual) - 191, 192
- Fishboxes - 72, 164
- FLIR thermal camera - 110
- Flooring care - 197
- Freshwater activation - 165
- Freshwater pump and strainer - 175
- Freshwater sink - 78
- Freshwater tank - 174
- Fuel (Engine) - 132
- Fusion stereo - 107
- Fuses - 151

G

Garmin WDUv2 - 171
Gas vapor detection - 191
Gel coat care - 196
Generator (AC) - 139
Generator (DC) - 145
GFCI - 155
Grills - 78
Gunwale washdowns - 77

H

Hardtop lighting - 167
Head - 123, 176
Helm breaker panel - 109, 152
Helm chartplotters - 157
Helm seats - 80
High water alarm - 194
House and electronics batteries - 150
Hull bottom care - 200
Humphree Lightning trim tabs - 108

K

Kill switch (Engine) - 134
KVH satellite - 127

L

Lazarette compartment lighting - 168
Lazarette compartment hatch - 73, 163
LivePower - 144

M

Mastervolt ChargeMaster Plus - 141
Mastervolt CombiMasters - 142, 144
Mastervolt MacPlus - 141, 143, 144
Metal care - 198
Mercury helm layout - 98
Mid-Berth - 126

N

Navigation lights - 167
NMEA 2000 network - 171

O

Oil (Engine) - 132
Optional rocket launcher - 74
Optional table - 74
Outriggers - 114
Overboard discharge - 182

P

Plastic care - 198
PowerPlatform - 64, 69, 163
PowerBank - 142
PowerShade - 112, 167
Propellers - 134

R

Radar - 110
Raw water activation - 165
Raw water manifold - 186
Refrigerator - 79
ReFlex flooring care - 197
Refreshment island - 77
RGBW lighting - 166

S

Sanitizing - 183
Seacocks - 185
Seagrass mat care - 197
Seakeeper - 159, 161, 187
Shore power reel - 64, 66, 146
Shore water - 125, 176
Shower - 124, 178
Shower box - 179
Stainless steel care - 198
Steering wheel - 109
Stern anchor - 64, 66
Sunroof - 112

T

Terrace Doors - 72, 165
Toilet controls - 177
Transom doors - 66
Transom washdown - 64, 65

U

UltraLounge - 64, 70, 71, 199
Upholstery Care - 198

V

V-Berth - 117
VHF radio - 105

W

Washdowns - 184
Waste tank - 180
Water heater - 122, 180
Windlass anchor - 83, 166
Windshield wipers - 106, 162
Winterization - 183

Y

Yamaha helm layout - 88