



Automation for a Changing World

Delta Multi-axis Motion Controller DVP15MC/50MC

6-axis / 24-axis Motion Controllers

- PLC-based multi-axis motion controllers designed for the CANopen/EtherCAT network architecture
- CANopen (DVP15MC)/EtherCAT (DVP50MC) with built-in motion control instructions (BufferMode and Jerk)
- Controls up to 24 real axes:
 - single axis motion control instructions such as speed, position, torque, homing, position setup
 - multi-axis motion control instructions such as electronic gear, electronic cam (E-Cam), rotatory cut and G-code
- Compatible with Delta AC Servo Drives (ASDA Series) via motion port

1 Motion Control

- Up to 24 real axes control (virtual axis no.: 1 ~ 32, can't be repetitive with real axis no.)
- Built-in motion control instructions, easy to use
- Supports encoder axis and virtual axis
- Single axis motion control instructions: speed, torque, homing, and position
- Application instructions: electronic gear, E-Cam, and rotary cut
- G-code: 8 axes linear/arc/helical interpolation
- Coordinates motion control instructions

2 External Interfaces

- 1 CANopen port as host or slave station
- 1 motion port (DVP15MC: CANopen, DVP50MC: EtherCAT)
- 16 high-speed inputs / 8 high-speed outputs
- 2 incremental encoder interfaces
- 1 SSI absolute encoder interface
- Ethernet port(s): DVP15MC*2
DVP50MC*1
- 1 SD card slot
- 1 RS-232 port and 1 RS-485 port
- Extension:
 - Left-side: supports up to 8 DVP-S Series PLC modules (master/slave/load cell modules)
 - Right-side: compatible with DVP-S Series PLC modules (240 I/O points, 8 special modules)



3 Performance

- 1 GHz high-speed floating point operation
- High-precision computing: supports LREAL (Double-precision floating-point format)
- Synchronization time:
 - DVP15MC: 4 axes in 2ms, 8 axes in 4ms
 - DVP50MC: 32 axes in 1ms
- Program capacity: 20 MB
- Data capacity: 20 MB

4 Motion Network and Wiring

- DVP15MC
 - Motion network: CANopen
 - Communication speed: max. 1Mbps
 - Distance: max. 100m (at 500 kbps)
- DVP50MC
 - Motion network: EtherCAT
 - Communication speed: max. 100Mbps
 - Distance: max. 50m (Node-to-node)
- Simple wiring, plug-and-play

System Structure

The DVP15MC/DVP50MC Series provides multiple industrial networks with compatible communications: Ethernet (upper layer), EtherCAT, CANopen, DeviceNet, PROFIBUS DP (middle layer) and RS-485 (lower layer, support Modbus).

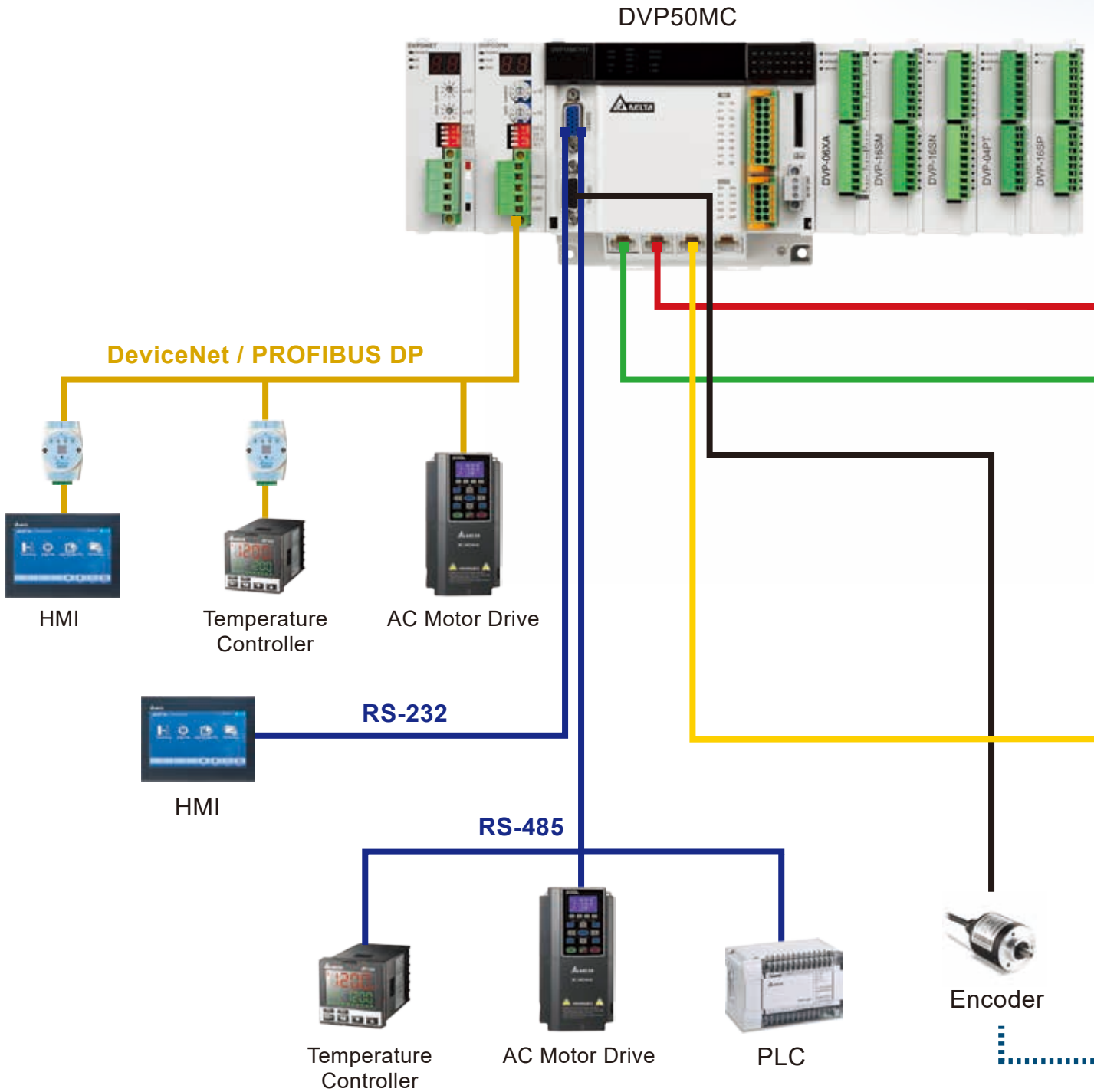

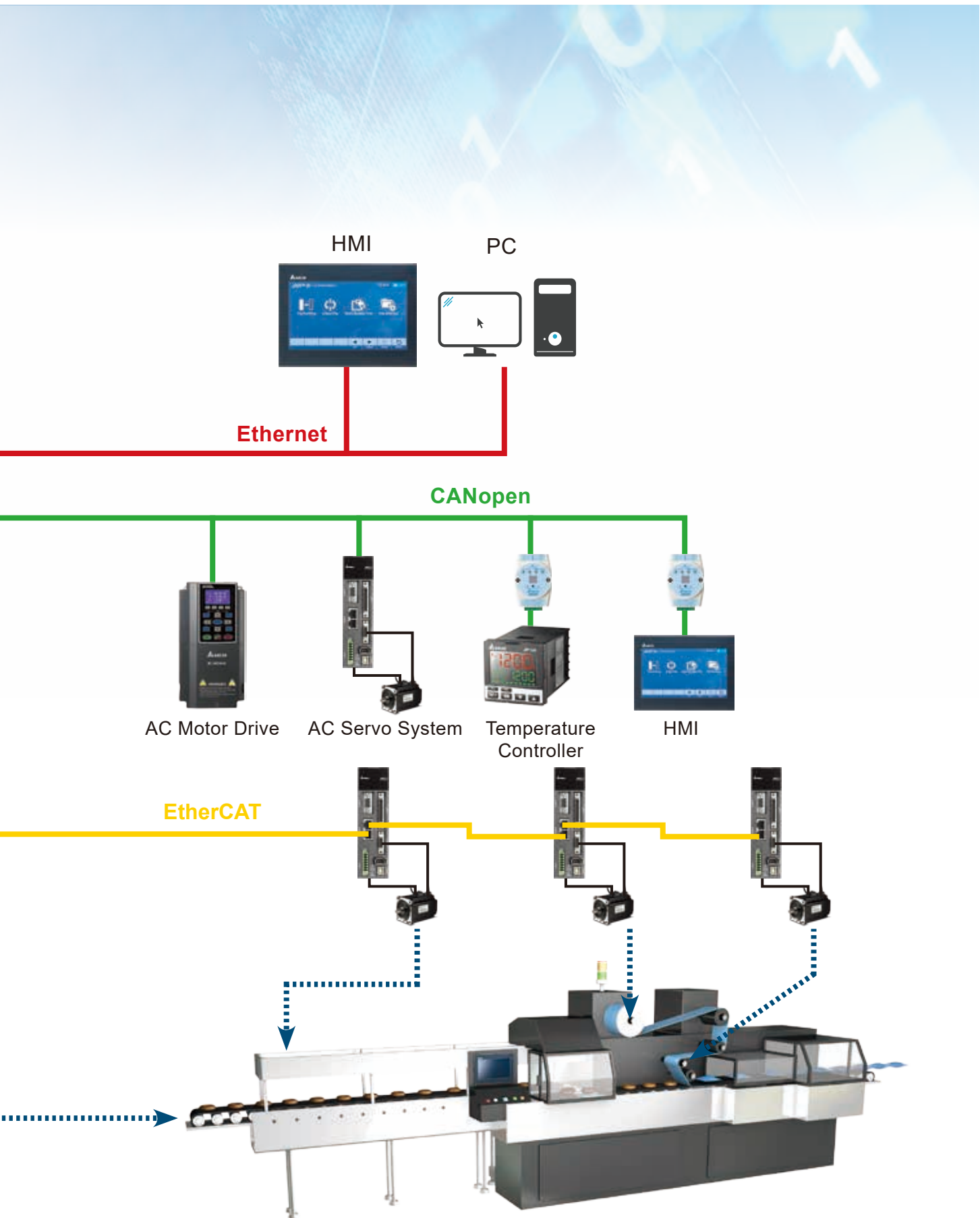

Ordering Information

Product Name	Multi-axis Motion Controller			
Power Supply	24V _{DC}			
Communication Protocol	CANopen DS402		EtherCAT	
Total Axes	32	16	32	16
Real Axes Control	24	6	24	6
Input	16	16	16	16
Output	8	8	8	8
Model Name	DVP15MC11T	DVP15MC11T-06	DVP50MC11T	DVP50MC11T-06
Certificates				

Dimensions (Unit: mm)

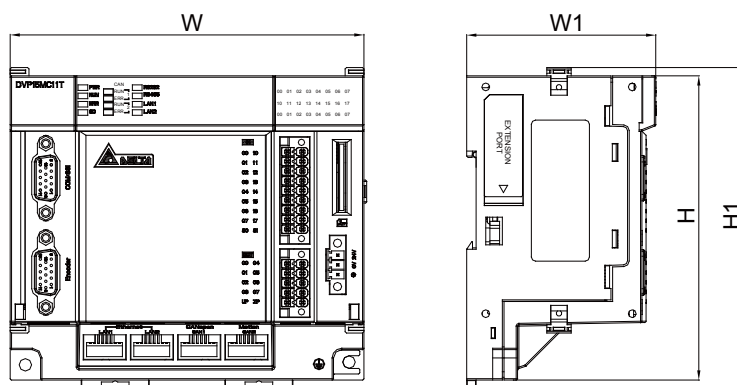

Model Name	H	H1	W	W1	Model Name	H	H1	W	W1
DVP15MC11T	110	116.2	128	68.4	DVP50MC11T	110	116.2	128	68.4
DVP15MC11T-06	110	116.2	128	68.4	DVP50MC11T-06	110	116.2	128	68.4

Applications



Machine Tool

- High-speed cutting machine
- CNC lathe
- Digital board cutting machine
- Polishing machine
- Edge sharpening machine
- Full servo milling machine



Electronics Manufacturing/Process

- Flexible printed circuit (FPC) inspection
- Carborundum coiling machine
- Carborundum electroplating machine
- Filming machine
- Feeding machine



Packaging

Beverage injecting machine



Printing

Woven bag printing machine



Smarter. Greener. Together.

Industrial Automation Headquarters

Delta Electronics, Inc.

Taoyuan Technology Center
No.18, Xinglong Rd., Taoyuan District,
Taoyuan City 33068, Taiwan
TEL: 886-3-362-6301 / FAX: 886-3-371-6301

Asia

Delta Electronics (Shanghai) Co., Ltd.

No.182 Minyu Rd., Pudong Shanghai, P.R.C.
Post code : 201209
TEL: 86-21-6872-3988 / FAX: 86-21-6872-3996
Customer Service: 400-820-9595

Delta Electronics (Japan), Inc.

Tokyo Office
Industrial Automation Sales Department
2-1-14 Shibadaimon, Minato-ku
Tokyo, Japan 105-0012
TEL: 81-3-5733-1155 / FAX: 81-3-5733-1255

Delta Electronics (Korea), Inc.

Seoul Office
1511, 219, Gasan Digital 1-Ro., Geumcheon-gu,
Seoul, 08501 South Korea
TEL: 82-2-515-5305 / FAX: 82-2-515-5302

Delta Energy Systems (Singapore) Pte Ltd.

4 Kaki Bukit Avenue 1, #05-04, Singapore 417939
TEL: 65-6747-5155 / FAX: 65-6744-9228

Delta Electronics (India) Pvt. Ltd.

Plot No.43, Sector 35, HSIIDC Gurgaon,
PIN 122001, Haryana, India
TEL: 91-124-4874900 / FAX : 91-124-4874945

Delta Electronics (Thailand) PCL.

909 Soi 9, Moo 4, Bangpoo Industrial Estate (E.P.Z),
Pattana 1 Rd., T.Phraksa, A.Muang,
Samutprakarn 10280, Thailand
TEL: 66-2709-2800 / FAX : 662-709-2827

Delta Energy Systems (Australia) Pty Ltd.

Unit 20-21/45 Normanby Rd., Notting Hill Vic 3168, Australia
TEL: 61-3-9543-3720

Americas

Delta Electronics (Americas) Ltd.

Raleigh Office
P.O. Box 12173, 5101 Davis Drive,
Research Triangle Park, NC 27709, U.S.A.
TEL: 1-919-767-3813 / FAX: 1-919-767-3969

Delta Greentech (Brasil) S/A

São Paulo Office
Rua Itapeva, 26 – 3º Andar - Bela Vista
CEP: 01332-000 – São Paulo – SP - Brasil
TEL: 55-11-3530-8642 / 55-11-3530-8640

Delta Electronics International Mexico S.A. de C.V.

Mexico Office
Vía Dr. Gustavo Baz No. 2160, Colonia La Loma,
54060 Tlalnepanitla Estado de Mexico
TEL: 52-55-2628-3015 #3050/3052

EMEA

Headquarter: Delta Electronics (Netherlands) B.V.

Sales: Sales.IA.EMEA@deltaww.com
Marketing: Marketing.IA.EMEA@deltaww.com
Technical Support: iatechnicalsupport@deltaww.com
Customer Support: Customer-Support@deltaww.com
Service: Service.IA.emea@deltaww.com
TEL: +31(0)40 800 3800

BENELUX: Delta Electronics (Netherlands) B.V.

De Witbogt 20, 5652 AG Eindhoven, The Netherlands
Mail: Sales.IA.Benelux@deltaww.com
TEL: +31(0)40 800 3800

DACH: Delta Electronics (Netherlands) B.V.

Coesterweg 45, D-59494 Soest, Germany
Mail: Sales.IA.DACH@deltaww.com
TEL: +49(0)2921 987 0

France: Delta Electronics (France) S.A.

ZI du bois Challand 2, 15 rue des Pyrénées,
Lisses, 91090 Evry Cedex, France
Mail: Sales.IA.FR@deltaww.com
TEL: +33(0)1 69 77 82 60

Iberia: Delta Electronics Solutions (Spain) S.L.U

Ctra. De Villaverde a Vallecas, 265 1º Dcha Ed.
Hormigueras – P.I. de Vallecas 28031 Madrid
TEL: +34(0)91 223 74 20

C/Llull, 321-329 (Edifici CINC) | 22@Barcelona, 08019 Barcelona

Mail: Sales.IA.Iberia@deltaww.com
TEL: +34 93 303 00 60

Italy: Delta Electronics (Italy) S.r.l.

Ufficio di Milano Via Senigallia 18/2 20161 Milano (MI)
Piazza Grazioli 18 00186 Roma Italy
Mail: Sales.IA.Italy@deltaww.com
TEL: +39 02 64672538

Russia: Delta Energy System LLC

Vereyskaya Plaza II, office 112 Vereyskaya str.
17 121357 Moscow Russia
Mail: Sales.IA.RU@deltaww.com
TEL: +7 495 644 3240

Turkey: Delta Greentech Elektronik San. Ltd. Sti. (Turkey)

Şerifali Mah. Hendem Cad. Kule Sok. No:16-A
34775 Ümraniye – İstanbul
Mail: Sales.IA.Turkey@deltaww.com
TEL: + 90 216 499 9910

GCC: Delta Energy Systems AG (Dubai BR)

P.O. Box 185668, Gate 7, 3rd Floor, Hamarain Centre
Dubai, United Arab Emirates
Mail: Sales.IA.MEA@deltaww.com
TEL: +971(0)4 2690148

Egypt + North Africa: Delta Electronics

511 Cairo Bussiness Plaza, North 90 street,
New Cairo, Cairo, Egypt
Mail: Sales.IA.MEA@deltaww.com