

Automation for a Changing World

# Delta Vector Control Drive C2000 Series



reddot design award  
winner 2010

[www.deltaww.com](http://www.deltaww.com)

 **DELTA**  
Smarter. Greener. Together.



# **Powerful Features. High Efficiency.**

The C2000 Series AC motor drive provides the most efficient solution for all types of drive applications. It features precise speed, torque and position control functions that are suitable for both sensor and sensorless types of synchronous and asynchronous motors. The C2000 Series is also equipped with built-in PLC functions and supports the CANopen Master/Slave extension for the ultimate in system flexibility and fast data exchange.

## Table of Contents

<b>Standard Models</b>	<b>3</b>
<b>Advanced Drive Controls</b>	<b>3</b>
<b>Modular Design</b>	<b>5</b>
<b>Certifications</b>	<b>6</b>
<b>LCD Keypad</b>	<b>7</b>
<b>Features and Applications</b>	<b>8</b>
High-speed networks	
Convenient operation platform	
High performance field oriented control	
Fast response to impact load	
Auto energy saving operation	
DEB function	
Permanent magnet motors (SPM, IPM)	
REG2000 Series	
AFE2000 Series	
<b>Active Front End AFE2000 Series</b>	<b>11</b>
<b>Operation Temperature and Protection Level</b>	<b>12</b>
<b>Environment for Operation, Storage and Transportation</b>	<b>13</b>
<b>Specifications</b>	<b>13</b>
Wiring	
Dimensions	
Option cards	
Ordering information	

## Standard Models (IP20/NEMA1)

Power range : 230V 0.75 ~ 90kW

230 V (kW)	0.75	1.5	2.2	3.7	5.5	7.5	11	15	18.5	22	30	37	45	55	75	90
230 V (HP)	1	2	3	5	7.5	10	15	20	25	30	40	50	60	75	100	125
Frame Size	A				B			C			D		E			F

Power range : 460V 0.75 ~ 450kW

460 V (kW)	0.75	1.5	2.2	3.7	4.0	5.5	7.5	11	15	18.5	22	30	37	45	55	75
460 V (HP)	1	2	3	5	5	7.5	10	15	20	25	30	40	50	60	75	100
Frame Size	A						B			C			D0		D	

Power range: 575V 1.5~15kW

575 V (kW)	1.5	2.2	3.7	5.5	7.5	11	15
575 V (HP)	2	3	5	7.5	10	15	20
Frame Size	A			B			

Power range: 690V 18.5~630kW

690 V (kW)	18.5	22	30	37	45	55	75	90	110	132	160	200	250	315	400	450
690 V (HP)	25	30	40	50	60	75	100	125	150	175	215	270	335	425	530	600
Frame Size	C			D		E			F		G			H		

## Advanced Drive Controls

### High Performance

1. High bandwidth control
2. Speed / torque / position control mode
3. Dual rating design (normal duty / heavy duty)
4. 4-quadrant torque control and limit
5. For both synchronous and asynchronous motors

### Environmental Adaptability

1. 50°C operating temperature
2. Built-in DC reactor
3. Coated circuit boards
4. Built-in EMC filter
5. International safety standard (CE/UL/cUL)

\*Note: Please refer to the Product Specification



90	110	132	160	185	220	280	315	355	450
125	150	175	215	250	300	375	425	475	600
E		F		G		H			

560	630
745	840

#### ▪ Versatile Drive Controls

1. Built-in safe stop function
2. Built-in PLC function
3. Built-in brake unit
4. Supports various network protocols
5. Position control

#### ▪ Modular Design

1. Hot pluggable LCD keypad
2. I/O extension cards
3. Various PG (encoder) feedback cards
4. Network cards for fieldbus modules
5. Removable fan



# Modular Design

Various accessories options, such as I/O extension cards, encoder feedback cards, communication cards, hot pluggable LCD keypad, removable terminals and removable fans.

## ▶ PG (Encoder) cards

EMC-PG010 / EMC-PG020



EMC-PG01U / EMC-PG02U



EMC-PG01L / EMC-PG02L



EMC-PG01R



## ■ Removable fan

To ensure personal safety, do not begin wiring before the indicator light is off.

## ■ Power indicator

To prevent personal injury, please do not perform wiring before power indicator is off.

## ■ Removable terminals

Convenient wiring and safety equipment.

Analog I/O switch

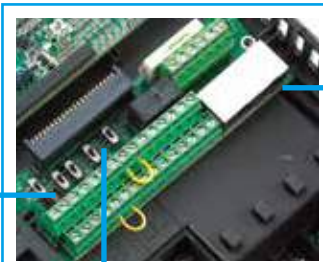
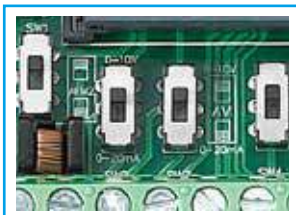

Termination resistor



Dual RJ45 communication ports

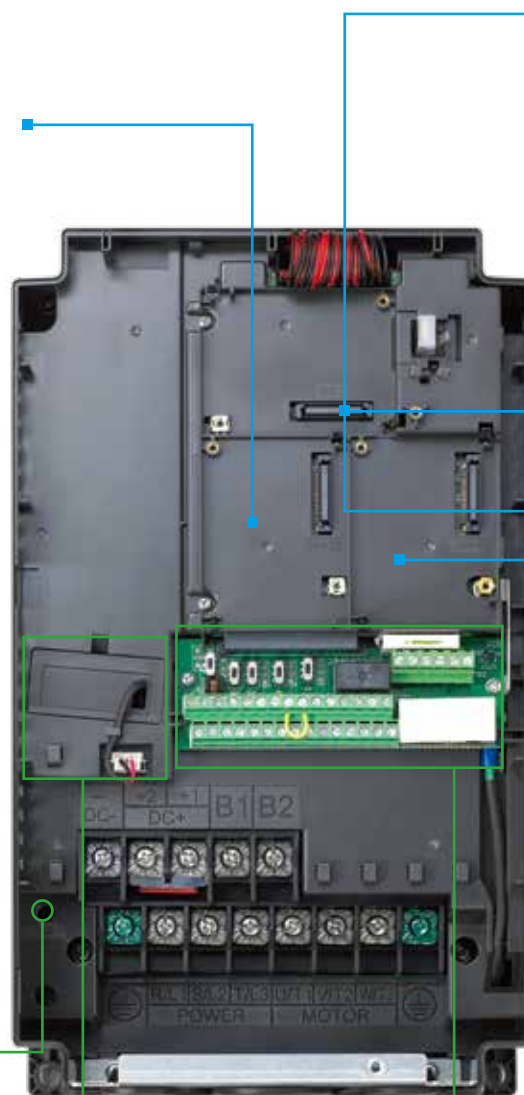
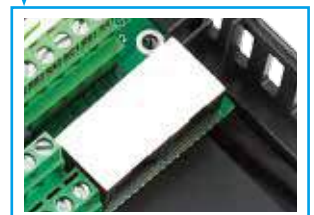

## ▶ I/O extension cards

EMC-D611A



EMC-D42A



EMC-A22A



EMC-BPS01



## ▶ Relay Extension Card

EMC-R6AA



## ▶ Communication cards

CMC-PD01



CMC-DN01



CMC-MOD01 / CMC-EIP01



EMC-COP01



CMC-EC01



\*NOTE: "▶" are optional accessories.

**The modular design fulfills the needs of system applications and equipment maintenance.**

- KPC-CC01 keypad
- Standard RJ45 network cable for remote operation.
- Easy to remove with one press.



- The product nameplate shows the input / output voltage, input / output current, the frequency range, and more.



- Remove the safety screws and press on both side tabs to remove the cover.



- Modular fan design, easy to replace and clean, extending product service life.



- RFI Jumper



## Excellent Environment Adaptability

- ▶ Built-in DC choke to suppress harmonics\*
- ▶ Built-in EMC filter to filter noise\*
- ▶ Conformal coating (Class 3C3 of IEC60721-3-3 standard) ensures drive operation stability and safety in critical environments.
- ▶ The electronic components of the drive are isolated from the cooling system to reduce heat interference. Dissipated heat can be discharged by flange-mounting installation, and forced fan cooling can import cold air into the heat sink. The heat dissipation performance is optimized by these two cooling methods.

\*Note: Please refer to the Product Specification



## Certifications

<b>UL, cUL</b>	<b>CE</b>
<b>C-Tick</b>	Low Voltage: EN61800-5-1
<b>ROHS</b>	EMC: EN61000-3-12, EN61800-3, IEC61000-6-2, IEC61000-6-4, IEC61000-4-2, IEC61000-4-3, IEC61000-4-4, IEC61000-4-5, IEC61000-4-6, IEC61000-4-8

# Quick and Easy Parameters Setting via the LCD Keypad

- Multi-column display for the drive status
- Simple and intuitive operation
- User-defined parameter groups
- Real Time Clock and calendar function
- Language selection for display
- Copy function saves parameters and PLC programs to the keypad memory for later transfer to another drive
- IP66 protection level



F1 to F4: User-defined function keys

Selection keys

LED displays the current drive status



Create homepage logo



Editable message display

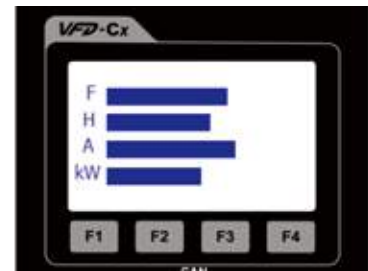

Editable chart display

# Intelligent PLC Functions

- Built-in 10K steps capacity of PLC functions. Distributed control and independent operation are easily achieved via network connection.
- CANopen Master protocol and PLC functions provide synchronous control and fast data exchange.

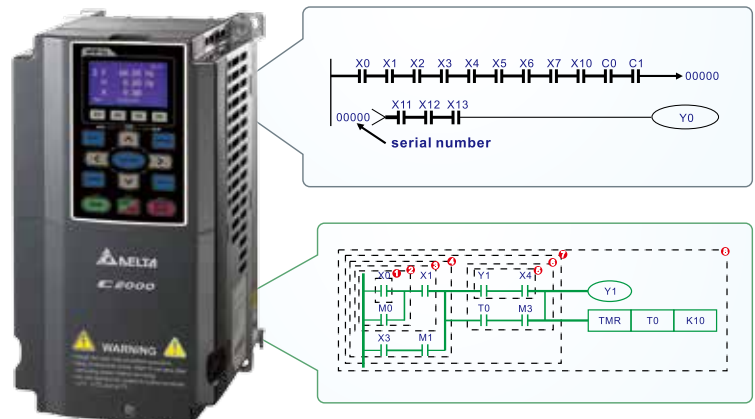

# High-Speed Network

- ▶ Provides optional MODBUS RTU and various fieldbus cards for flexible applications



## ■ CANopen (DS402)

Ability to control up to 8 Slave drives via the CANopen Master function

- Supports all Delta industrial automation products (Built-in EDS files for all Delta industrial automation products)
- I/O data configurations for each device on the CANopen network
- Motion control planning function
- WPL Soft

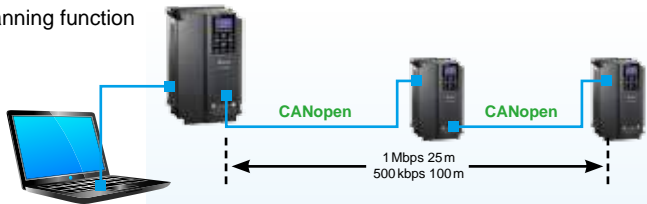

- TAP-CN03 distribution box for long distances



- RJ45 cable



## ■ DeviceNet

Through the Delta specially designed DeviceNet Builder software, users can easily establish a standard DeviceNet control network by the parameter pre-assignment function for each equipment and remote I/O.

- Supports all Delta industrial automation products (Built-in EDS files for all Delta industrial automation products)
- I/O data configurations for each device on the DeviceNet network
- DeviceNet layout software



## ■ EtherNet/IP

### ■ MODBUS TCP

Delta provides communication integrator software that offers graphic module settings and a user friendly interface to support all Ethernet products settings and online monitoring.

- Delta software for Ethernet/MODBUS TCP products
- Graphic module settings and a user friendly interface
- Auto search function
- Supports Virtual COM settings



# Convenient Drive System Management Platform

- Provides a complete operation platform for users' easy control and monitoring via PC, including parameters save/setting, real-time wave monitor, quick setup, for multiple languages and with multi-language operation systems.

**Start-up display**  
Displays horsepower, rated voltage and current of the drive in use.

**Parameter management**  
Provides parameter setting/save/copy/comparison for convenient parameter management.

**Trend records**  
Monitors the drive operation form via network and displays I/O terminal status. Useful for tasks such as "trial run monitoring".

**Quick setup**  
Guides the user step-by-step through the drive settings according to quick setup wizard.

\*NOTE: These software programs are available for download on Delta's website

# High-Performance Field Oriented Control

The FOC+PG mode of C2000 Series can output 150% of starting torque at extremely low speeds for precise and stable speed control.

Precise position and speed control ideal for printing machine applications.

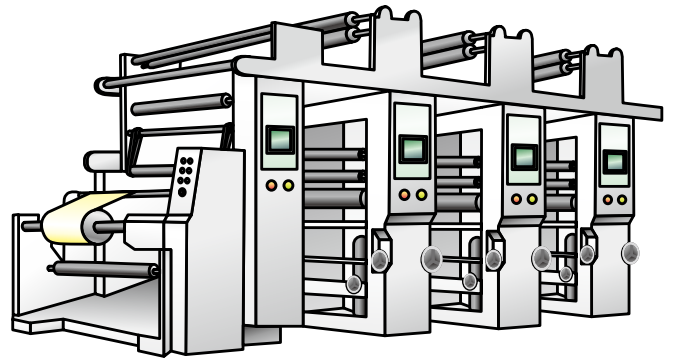
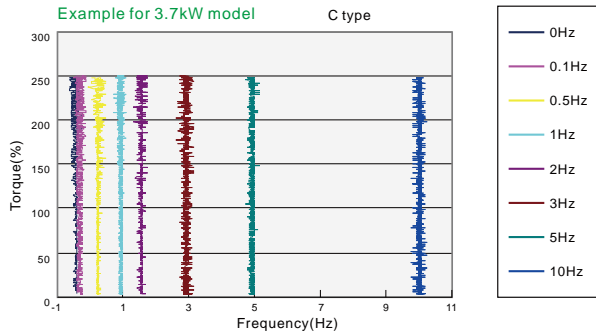

## Fast Response to Impact Load

During load changes, the C2000 Series calculates the required torque response and minimizes the vibration caused by load impact using FOC.

## Auto Energy-Saving Operation

Auto-calculates the optimal voltage for the load output using load power when under constant speed operation.

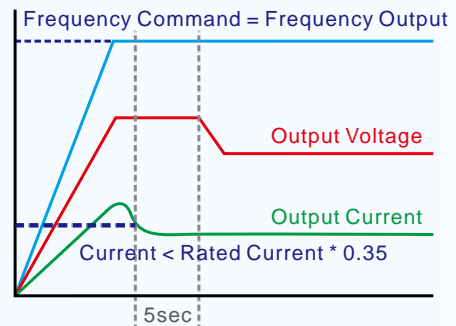
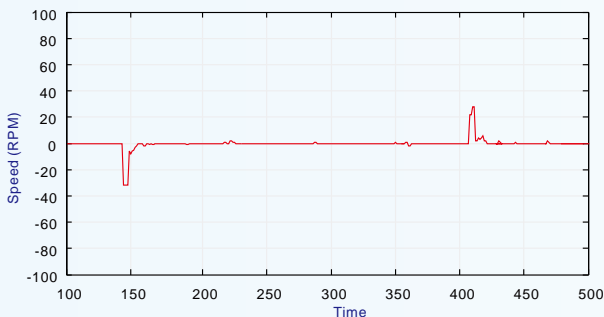

## Deceleration Energy Backup (DEB)

This function controls the motor deceleration to stop when power blinks off to prevent mechanical damage and then accelerates to its original operation speed when power resumes.

— Input Voltage  
— Motor Speed

— Input Voltage  
— Motor Speed

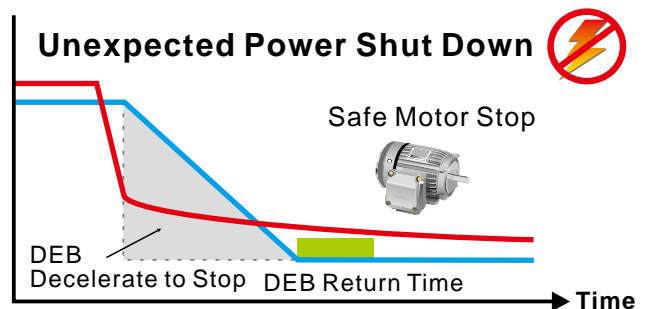
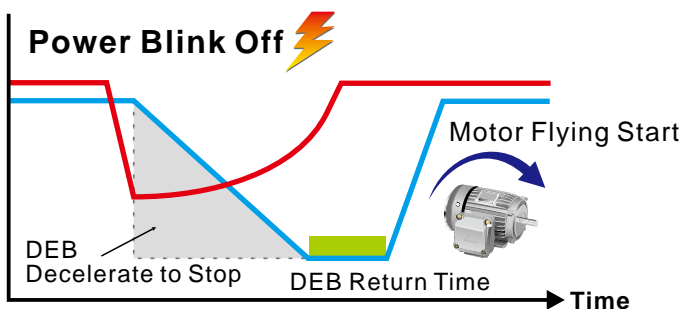

## A Drive for Permanent Magnet (PM) Motors

The C2000 is a dual mode drive to control both an induction motor and permanent magnet motor. The dynamic response of a PM motor provides precise control of position, speed and torque.

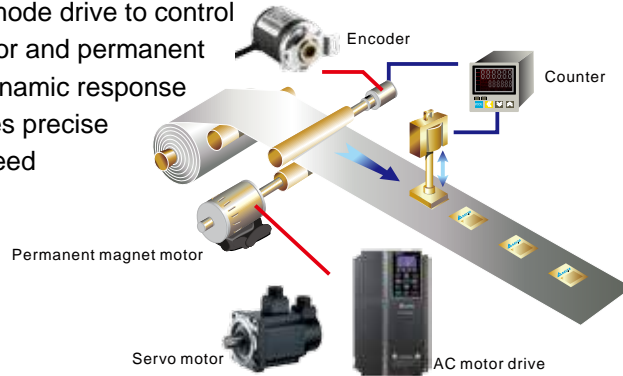

## Delta REG2000 Series for Power Regeneration

Using the REG2000 with the C2000 in a crane and hoist application provides the user with a four-quadrant operation and energy saving results.

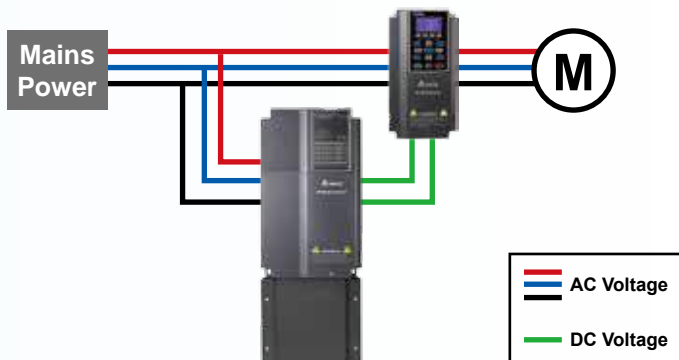

## Delta AFE2000 Series for Power Regeneration and Power Quality Improvement

The Active Front End Unit (AFE2000) helps to reduce torque ripple and harmonics with a higher power factor to provide excellent production quality and outstanding energy saving results.



# Delta Active Front End AFE2000 Series

## Features

- Replaces traditional brake resistor to reduce heat generation.
- Clear energy savings: more than 95% of the regenerative energy is converted into electricity and supplied back to the mains.
- Full-load operation: input-side current THD lower than 5% and improves power factor up to 99%.
- AC motor drives with AFE2000: supports 4-quadrant operation with variable frequencies and adjustable system.
- Constant DC bus voltage: unaffected by mains voltage fluctuations.



## Improves power factor and decreases harmonic distortion.

THD ≤ 5%, power factor > 99%

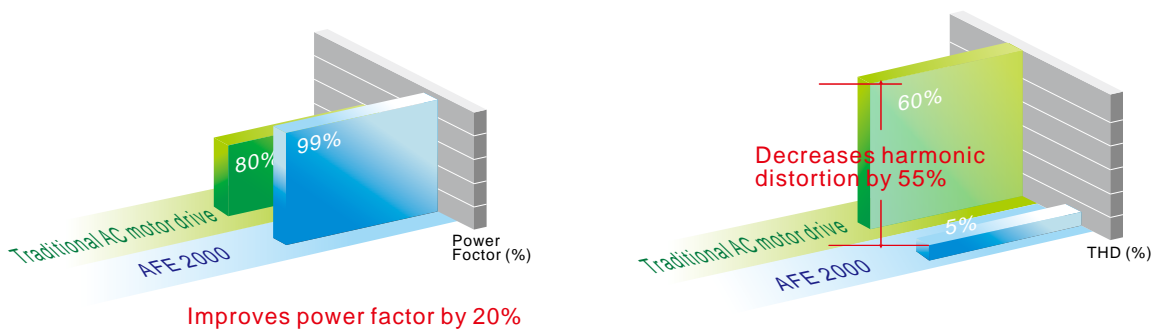

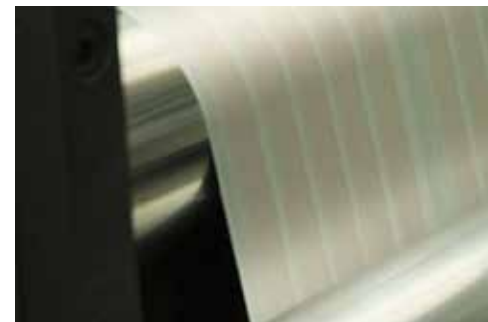

## Applications

- Large-inertia loads, such as centrifuge equipment, dewatering machines and roving machines
- 4-quadrant loads including elevators, cranes and pumpjacks (oil extraction machines)
- Quick braking, such as machine tools, bag making machines, auto storage and retrieval systems, and lathes
- Long-term energy feedback, such as wind power, water power, steel printing and paper making machinery (winding equipment)
- Improves power quality for industries such as semiconductor and panel industries



# Operation Temperature and Protection Level

Model	Frame	Top Cover	Conduit Box	Protection Level	Operation Temperature
VFDxxxCxxA VFDxxxCxxS	Frame A ~ C 230V: 0.75 ~ 22kW 460V: 0.75 ~ 30kW	Remove top cover	Standard conduit plate	IP20 / UL Open Type	-10°C ~ 50°C
		Standard with top cover		IP20 / UL Type1 / NEMA1	-10°C ~ 40°C
	Frame D ~ H 230V: > 22kW 460V: > 30kW	N / A	No conduit box	 Protection degree for the circled area is IP00, other areas are IP20	-10°C ~ 50°C
VFDxxxCxxE VFDxxxCxxU	Frame A ~ C 460V: 0.75 ~ 30kW	Remove top cover	Standard conduit plate	IP20 / UL Open Type	-10°C ~ 50°C
		Standard with top cover		IP20 / UL Type1 / NEMA1	-10°C ~ 40°C
	Frame D ~ H 230V: > 22kW 460V: > 30kW	N / A	Standard conduit box	IP20 / UL Type1 / NEMA1	-10°C ~ 40°C
VFDxxxC53A-21 VFDxxxC63B-21	Frame A ~ C 1.5 ~ 37kW	Remove top cover	Standard conduit plate	IP20 / UL Open Type	-10°C ~ 50°C
		Standard with top cover		IP20 / UL Type1 / NEMA1	-10°C ~ 40°C
VFDxxxC63B-21	Frame D ~ H > 45kW	N / A	Standard conduit box	IP20 / UL Type1 / NEMA1	-10°C ~ 40°C
VFDxxxC63B-00	Frame D ~ H > 45kW	N / A	No conduit box	 Protection degree for the circled area is IP00, other areas are IP20	-10°C ~ 50°C



# Environment for Operation, Storage and Transportation

DO NOT expose the AC motor drive to harsh environments, such as dust, direct sunlight, corrosive/flammable gasses, humidity, liquid or vibrations. The salts in the air must be less than 0.01 mg/cm<sup>2</sup> per year.

Environment	<b>Installation Location</b>	IEC60364-1/IEC60664-1 Pollution degree 2, indoor use only	
	<b>Surrounding Temperature (°C)</b>	Storage/Transportation	-25 ~ 70
		Only allowed in non-condensation, non-frost, non-conductive environment.	
	<b>Rated Humidity</b>	Operation/Storage/Transportation	Max. 95%
		Only allowed in non-condensation, non-frost, non-conductive environment.	
	<b>Air Pressure (kPa)</b>	Operation/Storage	86 ~ 106
		Transportation	70 ~ 106
	<b>Pollution Level</b>	IEC60721-3-3	
		Operation	Class 3C3; Class 3S2
		Storage	Class 1C2; Class 1S2
Transportation		Class 2C2; Class 2S2	
<b>Altitude</b>	If the AC motor drive is to be used under harsh environment with high level of contamination (e.g. dew, water, dust), make sure it is installed in an environment qualified for IP54 such as in a cabinet.		
	Operation	If the AC motor drive is installed at an altitude 0 ~ 1000m, follow normal operation restriction. If it is installed at altitude 1000 ~ 2000m, decrease 1% of rated current or lower 0.5°C of temperature for every 100m increase in altitude. Maximum altitude for Corner Grounded TN system is 2000m, for application over 2000m please contact Delta for more details.	
<b>Package Drop</b>	Storage/Transportation	ISTA procedure 1A (according to weight) IEC60068-2-31	
<b>Vibration</b>	1.0mm, peak to peak value range from 2Hz to 13.2Hz; 0.7G ~ 1.0G range from 13.2 Hz to 55Hz; 1.0G range from 55Hz to 512Hz. Comply with IEC 60068-2-6.		
<b>Impact</b>	IEC/EN 60068-2-27		
<b>Operation Position</b>	Max. allowed offset angle ±10° (under normal installation position)		

## Specifications

230V																			
Frame Size		A				B			C			D		E		F			
Model VFD- □□□C□□		007	015	022	037	055	075	110	150	185	220	300	370	450	550	750	900		
Output Rating *	NORMAL DUTY	Rated Output Capacity (kVA)	2.0	3.2	4.4	6.8	10	13	20	26	30	36	48	58	72	86	102	138	
		Rated Output Current (A)	5	8	11	17	25	33	49	65	75	90	120	146	180	215	255	346	
		Applicable Motor Output (kW)	0.75	1.5	2.2	3.7	5.5	7.5	11	15	18.5	22	30	37	45	55	75	90	
		Applicable Motor Output (HP)	1	2	3	5	7.5	10	15	20	25	30	40	50	60	75	100	120	
		Overload Capacity	120% of rated current: 1 minute for every 5 minutes; 160% of rated current: 3 seconds for every 30 seconds																
	HEAVY DUTY	Max. Output Frequency (Hz)	0.00 ~ 599.00																
		Carrier Frequency (kHz)	2 ~ 15 (default setting 8)						2 ~ 10 (default setting 6)						2 ~ 9 (default setting 4)				
		Rated Output Capacity (kVA)	1.9	2.8	4.0	6.4	9.6	12	19	25	28	34	45	55	68	81	96	131	
		Rated Output Current (A)	4.8	7.1	10	16	24	31	47	62	71	86	114	139	171	204	242	329	
		Applicable Motor Output (kW)	0.4	0.75	1.5	2.2	3.7	5.5	7.5	11	15	19	22	30	37	45	55	75	
Input Rating	Input Current (A)	Normal Duty	6.4	12	16	20	28	36	52	72	83	99	124	143	171	206	245	331	
		Heavy Duty	6.1	11	15	18.5	26	34	50	68	78	95	118	136	162	196	233	315	
	Rated Voltage/Frequency	3-phase AC 200V ~ 240V (-15% ~ +10%), 50/60Hz																	
	Operating Voltage Range	170 ~ 264V <sub>ac</sub>																	
	Frequency Tolerance	47 ~ 63Hz																	
	Drive Weight (Kg)	2.6 ± 0.3				5.4 ± 1			9.8 ± 1.5			38.5 ± 1.5		64.8 ± 1.5		86.5 ± 1.5			
	Efficiency (%)	97.8																	
	Power Factor	> 0.98																	
	Cooling Method	Natural cooling								Fan cooling									
	Braking Chopper									Frame A, B, C: built-in				Frame D and above: optional					
DC Choke									Frame A, B, C: optional				Frame D and above: built-in						
EMC Filter	Optional																		
EMC-COP01	Optional																		

\* The factory setting is Normal Duty mode

## 460V

Frame Size		A					B			C				
Model VFD-□□□C□□		007	015	022	037	040	055	075	110	150	185	220	300	
Output Rating *	NORMAL DUTY	Rated Output Capacity (kVA)	2.4	3.2	4.8	7.2	8.4	10	14	19	25	30	36	48
		Rated Output Current (A)	3.0	4.0	6.0	9.0	10.5	12	18	24	32	38	45	60
		Applicable Motor Output (kW)	0.75	1.5	2.2	3.7	4.0	5.5	7.5	11	15	18.5	22	30
		Applicable Motor Output (HP)	1	2	3	5	5	7.5	10	15	20	25	30	40
		Overload Capacity	120% of rated current: 1 minute for every 5 minutes; 160% of rated current: 3 seconds for every 30 seconds											
	HEAVY DUTY	Max. Output Frequency (Hz)	0.00 ~ 599.00											
		Carrier Frequency (kHz)	2 ~ 15 (default setting 8)						2 ~ 10 (default setting 6)					
		Rated Output Capacity (kVA)	2.3	3.0	4.5	6.5	7.6	9.6	14	18	24	29	34	45
		Rated Output Current (A)	2.9	3.8	5.7	8.1	9.5	11	17	23	30	36	43	57
		Applicable Motor Output (kW)	0.4	0.75	1.5	2.2	3.7	4.0	5.5	7.5	11	15	18.5	22
Input Rating	Input Current (A)	Normal Duty	4.3	5.9	8.7	14	15.5	17	20	26	35	40	47	63
		Heavy Duty	4.1	5.6	8.3	13	14.5	16	19	25	33	38	45	60
	Rated Voltage/Frequency	3-phase AC 380 V ~ 480 V (-15% ~ +10%), 50/60 Hz												
	Operating Voltage Range	323 ~ 528 V <sub>AC</sub>												
	Frequency Tolerance	47 ~ 63 Hz												
	Drive Weight (Kg)	2.6 ± 0.3					5.4 ± 1			9.8 ± 1.5				
	Efficiency (%)	97.8												
	Power Factor	> 0.98												
	Cooling Method	Natural cooling					Fan cooling							
	Braking Chopper	Frame A, B, C: built-in; Frame D and above: optional												
DC Choke	Frame A, B, C: optional; Frame D and above: built-in													
EMC Filter	VFDXXC43A: Optional; Frame A-C VFDXXC43E: Built-in													
EMC-COP01	VFDXXC43A: optional; VFDXXC43E: built-in													

## 460V

Frame Size		D0		D		E		F		G		H					
Model VFD-□□□C□□		370	450	550	750	900	1100	1320	1600	1850	2200	2800	3150	3550	4500		
Output Rating *	NORMAL DUTY	Rated Output Capacity (kVA)	58	73	88	120	143	175	207	247	295	367	438	491	544	720	
		Rated Output Current (A)	73	91	110	150	180	220	260	310	370	460	550	616	683	866	
		Applicable Motor Output (kW)	37	45	55	75	90	110	132	160	185	220	280	315	355	450	
		Applicable Motor Output (HP)	50	60	75	100	125	150	175	215	250	300	375	420	475	600	
		Overload Capacity	120% of rated current: 1 minute for every 5 minutes; 160% of rated current: 3 seconds for every 30 seconds														
	HEAVY DUTY	Max. Output Frequency (Hz)	0.00 ~ 599.00														
		Carrier Frequency (kHz)	2 ~ 10 (default setting 6)						2 ~ 9 (default setting 4)								
		Rated Output Capacity (kVA)	55	69	84	114	136	167	197	235	280	348	417	466	517	677	
		Rated Output Current (A)	69	86	105	143	171	209	247	295	352	437	523	585	649	815	
		Applicable Motor Output (kW)	30	37	45	55	75	90	110	132	160	185	220	280	315	355	
Input Rating	Input Current (A)	Normal Duty	74	101	114	157	167	207	240	300	380	400	494	555	625	866	
		Heavy Duty	70	96	108	149	159	197	228	285	361	380	469	527	594	815	
	Rated Voltage/Frequency	3 - phase AC 380 V ~ 480 V (-15% ~ +10%), 50/60 Hz															
	Operating Voltage Range	323 ~ 528 V <sub>AC</sub>															
	Frequency Tolerance	47 ~ 63 Hz															
	Drive Weight (Kg)	27 ± 1.5			38.5 ± 1.5			64.8 ± 1.5		86.5 ± 1.5		134 ± 4		228			
	Efficiency (%)	97.8															
	Power Factor	> 0.98															
	Cooling Method	Fan cooling															
	Braking Chopper	Frame A, B, C: built-in; Frame D and above: optional															
DC Choke	Frame A, B, C: optional; Frame D and above: built-in																
EMC Filter	Frame D0-H: Optional																
EMC-COP01	VFDXXC43A: optional; VFDXXC43E: built-in																

\* The factory setting is Normal Duty mode

### NOTES

- 1) The carrier frequency is default. Increasing the carrier frequency requires a reduction in current. please refer to Pr. 06-55 Derating Protection drawing.
- 2) The AC motor drive should operate in derating current when its control method is set to FOC Sensorless, TQC+PG, TQC sensorless. PM+PG, PM sensorless. Please refer to Pr. 06-55 for more information.
- 3) Select the AC motor drive with capacity one grade larger for the impact load application.
- 4) The rated input current will be affected not only by Power Transformer and the connection of the reactors on input side, but also fluctuates with the impedance of power side.
- 5) For Frame A, B and C, Model VFDXXC43A is under IP20/NEMA1/UL TYPE1 protection level.
- 6) For Frame D and above, if the last character of the model is A then it is under IP20 protection level but the wiring terminal is under IP00 protection level;
- 7) if the last character of the model is E, it is under IP20/NEMA1/UL TYPE1 protection level.

## 575V

Frame Size		A			B				
Model VFD-□□□C53A-21		015	022	037	055	075	110	150	
Output *	Light Duty								
	Rated Output Capacity (kVA)	3	4.3	6.7	9.9	12.1	18.7	24.1	
	Rated Output Current (A)	3	4.3	6.7	9.9	12.1	18.7	24.2	
	Applicable Motor Output (kW)	1.5	2.2	3.7	5.5	7.5	11	15	
	Applicable Motor Output (HP)	2	3	5	7.5	10	15	20	
	Normal Duty								
	Rated Output Capacity (kVA)	2.5	3.6	5.5	8.2	10	15.4	19.9	
	Rated Output Current (A)	2.5	3.6	5.5	8.2	10	15.5	20	
	Applicable Motor Output (kW)	0.75	1.5	2.2	3.7	5.5	7.5	11	
	Applicable Motor Output (HP)	1	2	3	5	7.5	10	15	
	Heavy Duty								
	Rated Output Capacity (kVA)	2.1	3	4.6	6.9	8.3	12.9	16.7	
	Rated Output Current (A)	2.1	3	4.6	6.9	8.3	13	16.8	
Applicable Motor Output (kW)	0.75	1.5	2.2	3.7	3.7	7.5	7.5		
Applicable Motor Output (HP)	1	2	3	5	5	10	10		
Carrier Frequency (kHz)		2~15 (default setting 4)							
Input	Input Current (A)	Light Duty	3.8	5.4	10.4	14.9	16.9	21.3	26.3
		Normal Duty	3.1	4.5	7.2	12.3	15	18	22.8
		Heavy Duty	2.6	3.8	5.8	10.7	12.5	16.9	19.7
	Rated Voltage/Frequency		3-Phase 525 V <sub>AC</sub> ~600 V <sub>AC</sub> (-15%~+10%), 50/60 Hz						
Operating Voltage Range		446~660 V <sub>AC</sub>							
Frequency Tolerance		47~63 Hz							
Efficiency (%)		97			98				
Power Factor		>0.98							
AC Drive Weight (Kg)		3±0.3			4.8±1				
Cooling Method		Natural cooling			Fan cooling				
Braking Chopper		Built-in							
DC Choke		Optional							
EMC Filter		Optional							

## 690V

Frame Size		C				D		E				
Model VFD-□□□C63B-00 / -21		185	220	300	370	450	550	750	900	1100	1320	
Output *	Light Duty											
	Rated Output Capacity (kVA)	29	36	43	54	65	80	103	124	149	179	
	Applicable Motor Output (690V, kW)	18.5	22	30	37	45	55	75	90	110	132	
	Applicable Motor Output (690V, HP)	25	30	40	50	60	75	100	125	150	175	
	Applicable Motor Output (575V, HP)	20	25	30	40	50	60	75	100	125	150	
	Rated Output Current (A)	24	30	36	45	54	67	86	104	125	150	
	Normal Duty											
	Rated Output Capacity (kVA)	24	29	36	43	54	65	80	103	124	149	
	Applicable Motor Output (690V, kW)	15	18.5	22	30	37	45	55	75	90	110	
	Applicable Motor Output (690V, HP)	20	25	30	40	50	60	75	100	125	150	
	Applicable Motor Output (575V, HP)	15	20	25	30	40	50	60	75	100	125	
	Rated Output Current (A)	20	24	30	36	45	54	67	86	104	125	
	Heavy Duty											
Rated Output Capacity (kVA)	17	24	29	36	43	54	65	80	103	124		
Applicable Motor Output (690V, kW)	11	15	18.5	22	30	37	45	55	75	90		
Applicable Motor Output (690V, HP)	15	20	25	30	40	50	60	75	100	125		
Applicable Motor Output (575V, HP)	10	15	20	25	30	40	50	60	75	100		
Rated Output Current (A)	14	20	24	30	36	45	54	67	86	104		
Carrier Frequency (kHz)		2~9 (default setting 4)										
Input	Input Current (A)	Light Duty	29	36	43	54	65	81	84	102	122	147
		Normal Duty	24	29	36	43	54	65	66	84	102	122
		Heavy Duty	20	24	29	36	43	54	53	66	84	102
	Rated Voltage/Frequency		3-Phase 525 V <sub>AC</sub> ~690 V <sub>AC</sub> (-15%~+10%), 50/60Hz									
Operating Voltage Range		446~759 V <sub>AC</sub>										
Frequency Tolerance		47~63 Hz										
Efficiency (%)		97										
Power Factor		>0.98										
AC Drive Weight (Kg)		10±1.5				39±1.5			61±1.5			
Cooling Method		Fan cooling										
Braking Chopper		Frame C (built-in)					Frame D and above (optional)					
DC Choke		Frame C (optional)					Frame D and above (built-in)					
EMC Filter		Optional										

\* Parameter 00-16; available load modes: Light Duty (LD), Normal Duty (ND) and Heavy Duty (HD); default setting is LD mode

690 V										
Frame Size		F		G		H				
Model VFD-□□□C63B-00 / -21		1600	2000	2500	3150	4000	4500	5600	6300	
Output *	Light Duty	Rated Output Capacity (kVA)	215	263	347	418	494.5	534.7	678.5	776
		Applicable Motor Output (690V, kW)	160	200	250	315	400	450	560	630
		Applicable Motor Output (690V, HP)	215	270	335	425	530	600	745	850
	Normal Duty	Applicable Motor Output (575V, HP)	175	200	250	350	400	450	500	745
		Rated Output Current (A)	180	220	290	350	430	465	590	675
		Rated Output Capacity (kVA)	179	215	239	347	402.5	442.7	534.7	776
	Heavy Duty	Applicable Motor Output (690V, kW)	132	160	200	250	315	355	450	630
		Applicable Motor Output (690V, HP)	175	215	270	335	425	475	600	850
		Applicable Motor Output (575V, HP)	150	175	200	250	350	400	450	745
		Rated Output Current (A)	150	180	220	290	350	385	465	675
	Carrier Frequency (kHz)		2~9 (default setting 4)						2~9 (default setting 3)	
	Input	Input Current (A)	Light Duty	178	217	292	353	454	469	595
Normal Duty			148	178	222	292	353	388	504	681
Heavy Duty			123	148	181	222	292	313	423	681
Rated Voltage/Frequency		3-Phase 525 V <sub>AC</sub> ~ 690 V <sub>AC</sub> ( -15% ~ +10%), 50/60Hz								
Operating Voltage Range		446 ~ 759 V <sub>AC</sub>								
Frequency Tolerance		47 ~ 63Hz								
Efficiency (%)		97			98					
Power Factor		> 0.98								
AC Drive Weight (Kg)		88 ± 1.5		135 ± 4		243 ± 5				
Cooling Method		Fan cooling								
Braking Chopper		Frame D and above (optional)								
DC Choke		Frame D and above (built-in)								
EMC Filter		Optional								

\* Parameter 00-16; available load modes: Light Duty (LD), Normal Duty (ND) and Heavy Duty (HD); default setting is LD mode



# General Specifications

Control Characteristics	<b>Control Method</b>	Pulse Width Modulated (PWM)
	<b>Control Mode</b>	230 V / 460 V model: 1: V / F · 2: SVC · 3: VF+PG · 4: FOC+PG · 5: TQC+PG · 6: PM+PG · 7: FOC sensorless · 8: TQC sensorless · 9: PM sensorless 575 V / 690 V model: 1: V / F · 2: V / F+PG · 3: SVC
	<b>Starting Torque</b>	Reach up to 150% or above at 0.5 Hz. Under FOC+PG mode, starting torque can reach 150% at 0 Hz
	<b>V/F Curve</b>	4-point adjustable V/F curve and square curve
	<b>Speed Response Ability</b>	5 Hz (vector control can reach up to 40 Hz)
	<b>Torque Limit</b>	230 V / 460 V model: Normal duty 160%, heavy duty 180% of torque current ; 575 V / 690 V model: Maximum 200% of torque current
	<b>Torque Accuracy at TQC Mode</b>	TQC + PG : ±5% TQC Sensorless : ±15%
	<b>Max. Output Frequency (Hz)</b>	Light Duty / Normal duty: 0.01 ~ 599.00 Hz; Heavy duty: 0.00 ~ 300.00 Hz
	<b>Frequency Output Accuracy</b>	Digital command: ±0.01%, -10 ° C ~ +40 ° C, Analog command: ±0.1%, 25 ±10 ° C
	<b>Output Frequency Resolution</b>	Digital command: 0.01 Hz, Analog command: 0.03 * max. output frequency/60 Hz (±11 bit)
	<b>Overload Capacity</b>	230 V / 460 V model: Normal duty: 120% of rated current can endure for 1 minute during every 5 minutes ; 160% of rated current can endure for 3 seconds during every 30 seconds Heavy duty: 150% of rated current can endure for 1 minute during every 5 minutes ; 180% of rated current can endure for 3 seconds during every 30 seconds 575 V / 690 V model: Light duty: 120% of rated current can endure for 1 minute Normal duty: 120% of rated current can endure for 1 minute, 150% can endure for 3 seconds Heavy duty: 150% of rated current can endure for 1 minute, 180% can endure for 3 seconds
	<b>Frequency Setting Signal</b>	+10 V ~ -10 V, 0 ~ +10 V, 4 ~ 20 mA, 0 ~ 20 mA, pulse input
	<b>Accel./decel. Time</b>	0.00 ~ 600.00 / 0.0 ~ 6000.0 Seconds
<b>Main Control Function</b>	Torque control, Speed/torque control switching, Feed forward control, Zero-servo control, Momentary power loss ride thru, Speed search, Over-torque detection, Torque Limit, 16-step speed (Max.), Accel./decel time switch, S-curve accel./decel, 3-wire sequence, Auto-Tuning (rotational, stationary), Dwell, Slip compensation, Torque compensation, JOG frequency, Fault restart, Frequency upper/lower limit settings, DC injection braking at start/stop, High slip braking, Parameter copy PID control (with sleep function), Energy saving control, MODOBUS communication (RS-485 RJ45, Max. 115.2 kbps)	
<b>Fan Control</b>	230 V model: VFD150C23A (include) and series above: PMW control; VFD110C23A and below: on/off switch control 460 V model: VFD185C43A (include) and series above: PMW control; VFD150C43A and below: on/off switch control 575 V / 690 V model: PWM control	
Protection Characteristics	<b>Motor Protection</b>	Electronic thermal relay protection
	<b>Over-current Protection</b>	230 V / 460 V model: Over-current protection for 240% of rated current (Normal duty) Current clamp (Normal duty: around 170 ~ 175%); (Heavy duty: around 180 ~ 185%) 575 V / 690 V model: Over-current protection for 225% rated current (Normal duty) Current clamp (Light duty: around 128 ~ 141%); (Normal duty: around 170 ~ 175%); (Heavy duty: around 202% ~ 210%)
	<b>Over-Voltage Protection</b>	The C2000 Series will shut down under below conditions: 230 V: DC bus over 410 V; 460 V: DC bus over 820 V; 575 V / 690 V: DC bus over 1189 V
	<b>Over-Temperature Protection</b>	Built-in temperature sensor
	<b>Stall Prevention</b>	Stall prevention during acceleration, deceleration and running independently
	<b>Restart after Instantaneous Power Failure</b>	Parameter setting up to 20 seconds
	<b>Grounding Leakage Current Protection</b>	Leakage current is higher than 50% of rated current of the AC motor drive
<b>Short-circuit Current Rating (SCCR)</b>	Per UL508C, the drive is suitable for use on a circuit capable of delivering not more than 100kA symmetrical amperes (rms) when protected by fuses given in the fuse table	
<b>International Certifications</b>		

Note: EAC Certification is for 230V and 460V models only

# Wiring

## Wiring Diagram for Frame A ~ C

\*Input: 3-phase power

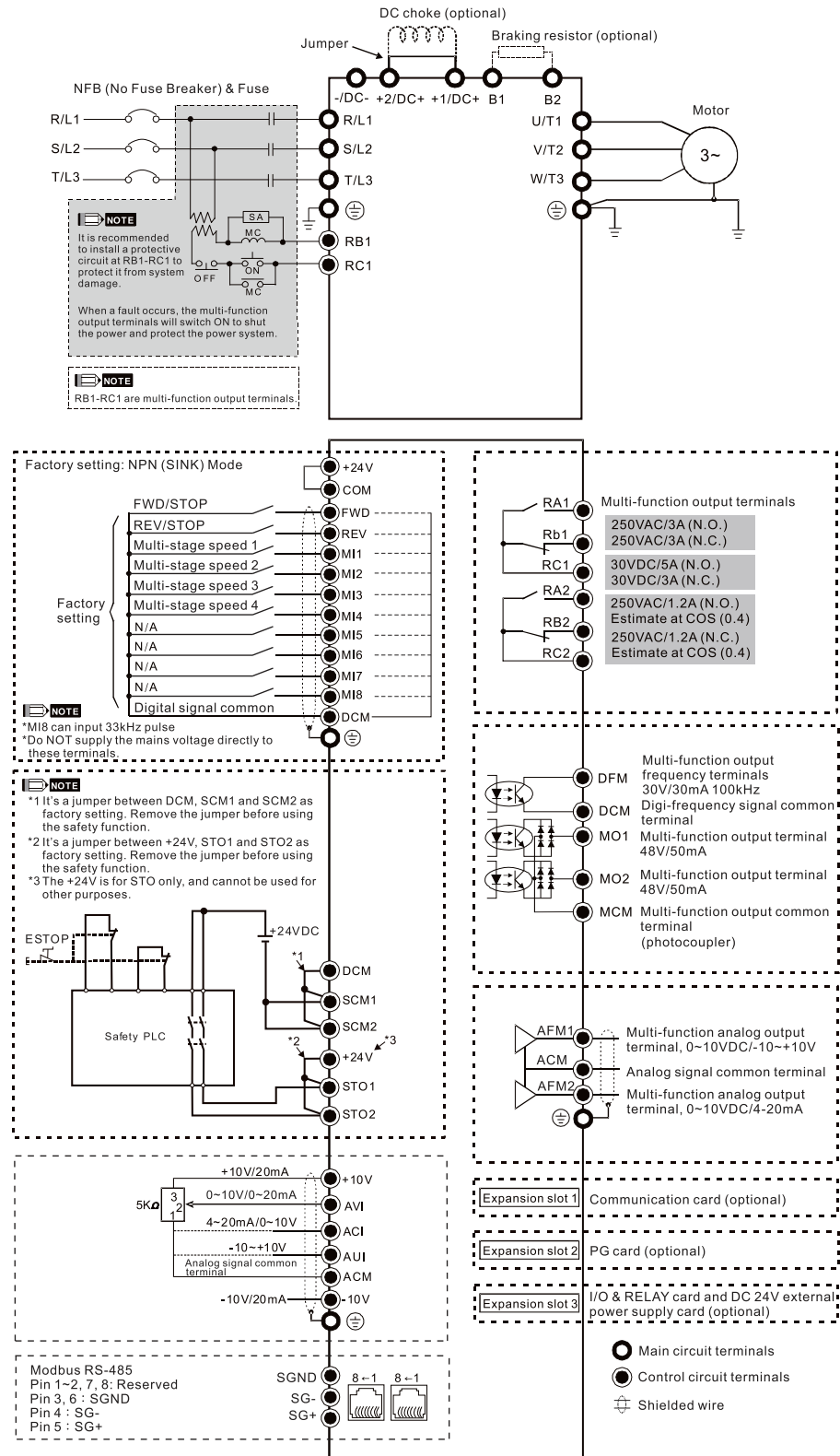

**NOTE**

It is not recommended to use a power capacitor or automatic power factor regulator (APFR) at the power input side. If the system requires such a device, please make sure a reactor is installed between the drive and the power capacitor or APFR.

# Wiring Diagram for Frame D ~ F

\*Input: 3-phase power

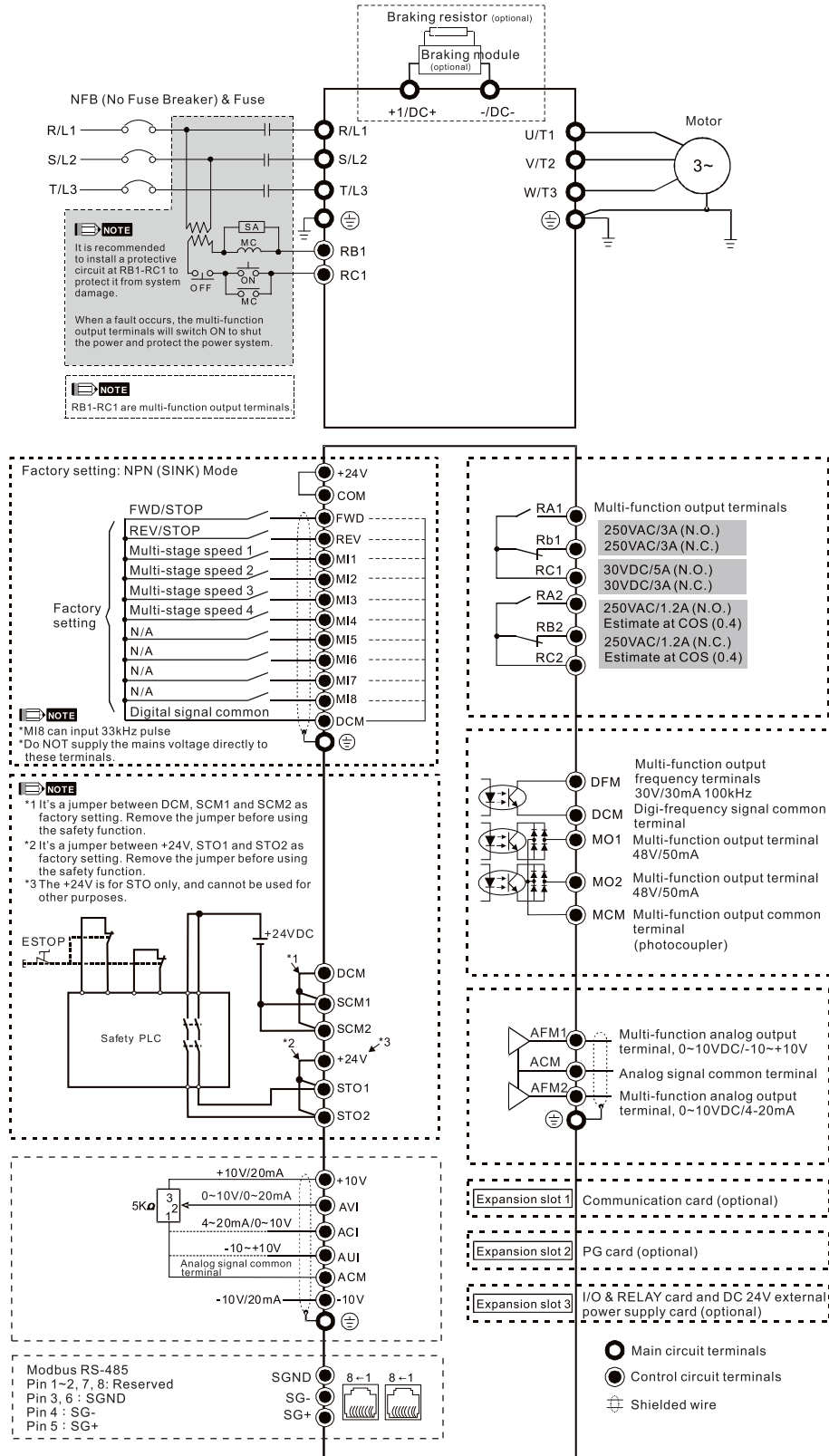

# Wiring Diagram for Frame G ~ H

\*Input: 3-phase power

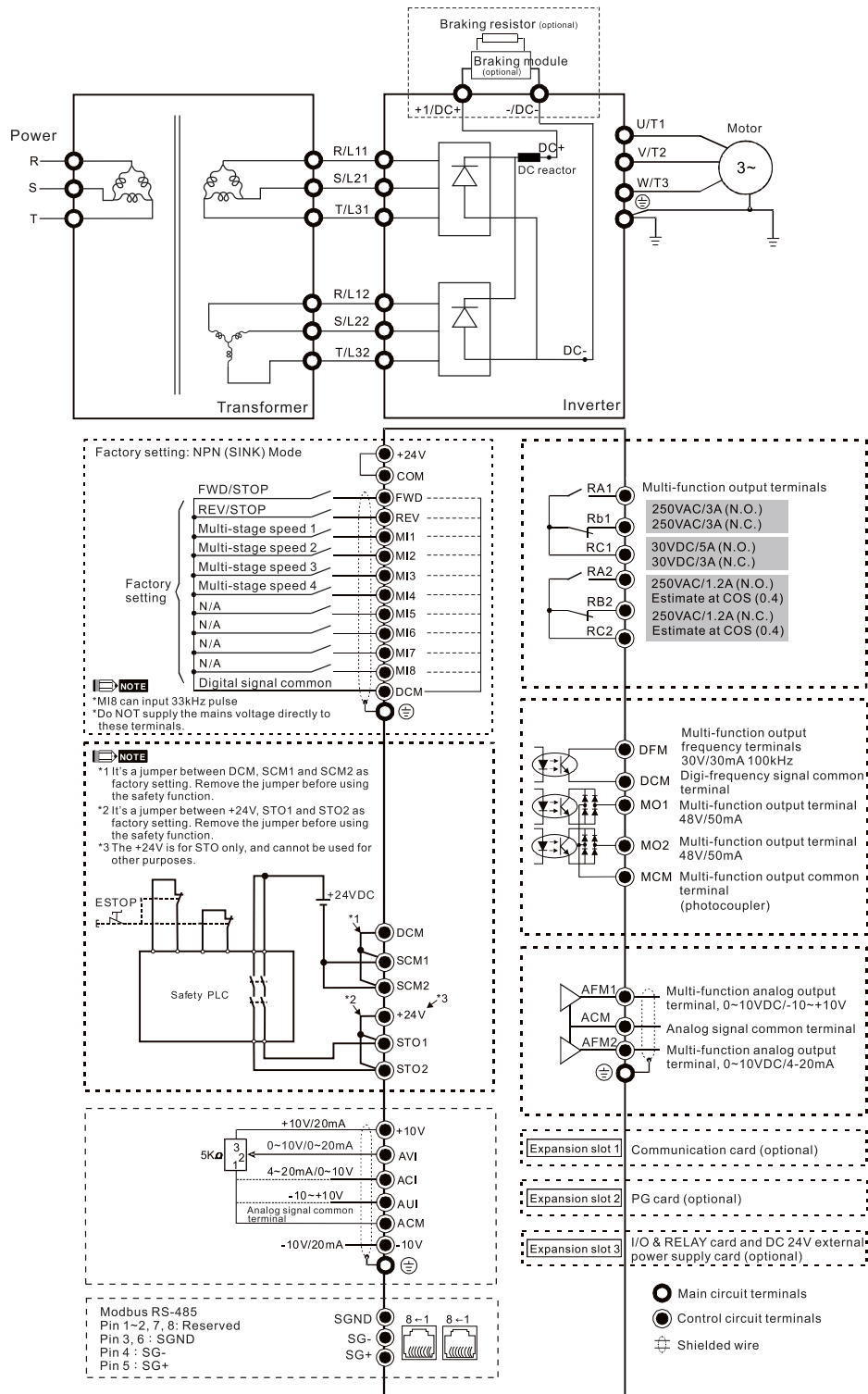

## NOTE

It is not recommended to use a power capacitor or automatic power factor regulator (APFR) at the power input side. If the system requires such a device, please make sure a reactor is installed between the drive and the power capacitor or APFR.

# Dimensions

Digital Keypad Unit: mm [inch]

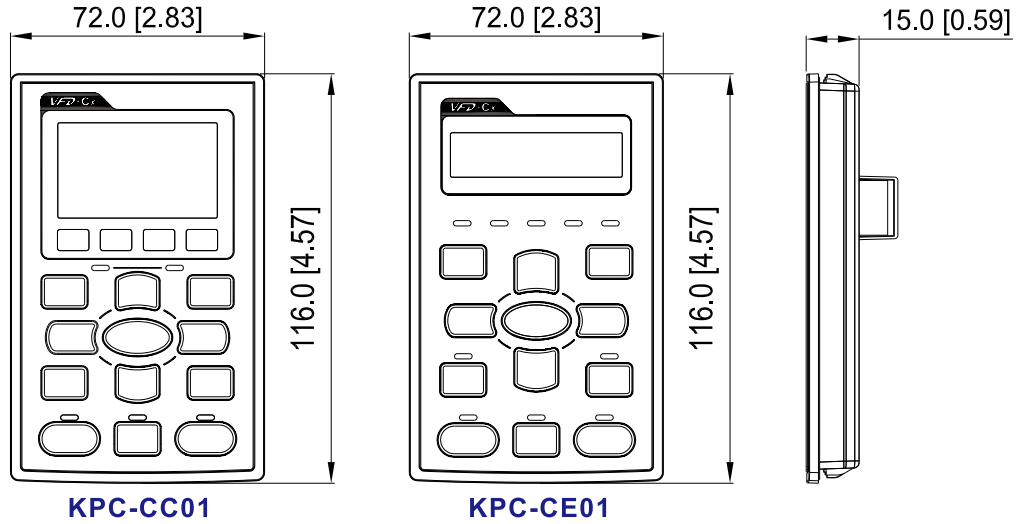

## Frame A

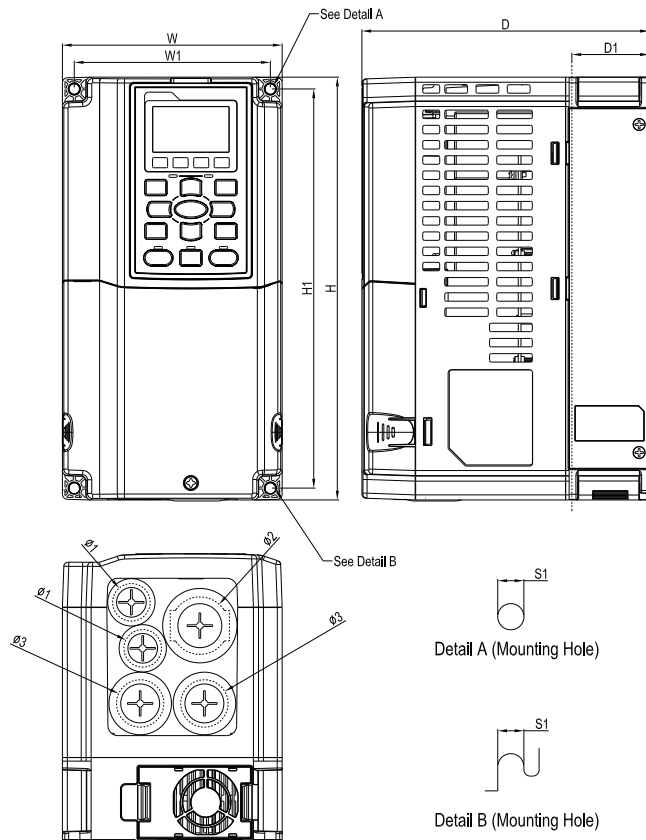

### MODEL FRAME\_A

- VFD007C23A
- VFD015C23A
- VFD022C23A
- VFD037C23A
- VFD007C43A / 43E
- VFD015C43A / 43E
- VFD022C43A / 43E
- VFD037C43A / 43E
- VFD040C43A / 43E
- VFD055C43A / 43E
- VFD015C53A-21
- VFD022C53A-21
- VFD037C53A-21

Frame	W	H	D	W1	H1	D1*	Ø	Ø1	Ø2	Ø3	
A1	mm	130.0	250.0	170.0	116.0	236.0	45.8	6.2	22.2	34.0	28.0
	inch	5.12	9.84	6.69	4.57	9.29	1.80	0.24	0.87	1.34	1.10

\*D1: Flange mount.

## Frame B

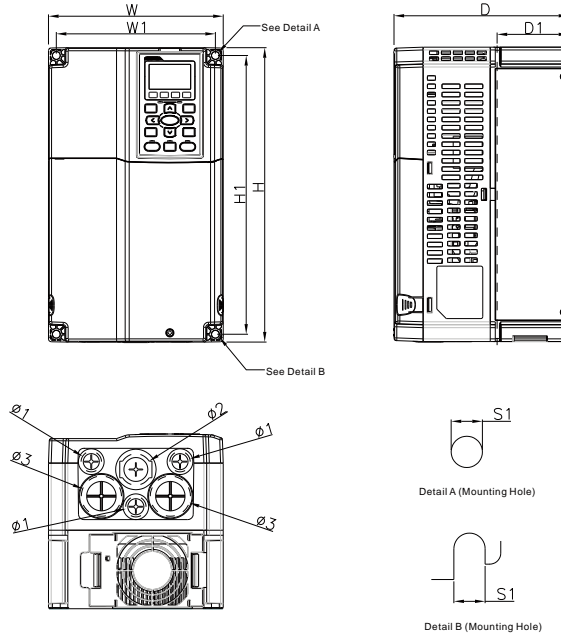

### MODEL

VFD055C23A  
 VFD075C23A  
 VFD110C23A  
 VFD075C43A / 43E  
 VFD110C43A / 43E  
 VFD150C43A / 43E  
 VFD055C53A-21  
 VFD075C53A-21  
 VFD110C53A-21  
 VFD150C53A-21

Frame	W	H	D	W1	H1	D1*	S1	Ø1	Ø2	Ø3	
B1	mm	190.0	320.0	190.0	173.0	303.0	77.9	8.5	22.2	34.0	28.0
	inch	7.48	12.60	7.48	6.81	11.93	3.07	0.33	0.87	1.34	1.10

\*D1: Flange mount.

## Frame C

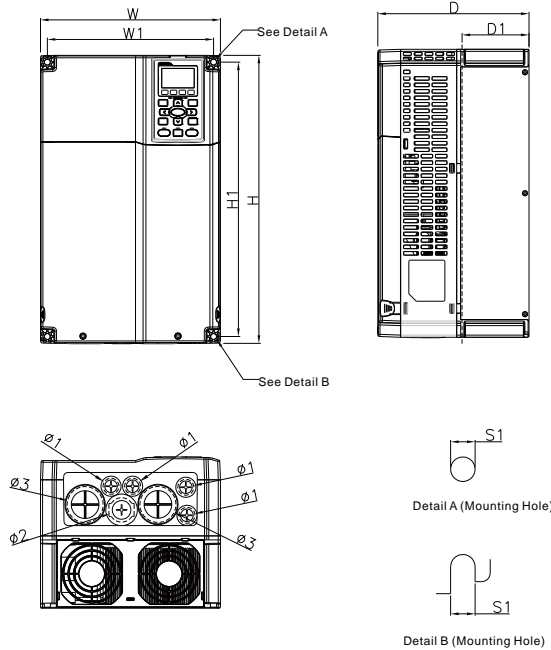

### MODEL

VFD150C23A  
 VFD185C23A  
 VFD220C23A  
 VFD185C43A / 43E  
 VFD220C43A / 43E  
 VFD300C43A / 43E  
 VFD185C63B-21  
 VFD220C63B-21  
 VFD300C63B-21  
 VFD370C63B-21

Frame	W	H	D	W1	H1	D1*	S1	Ø1	Ø2	Ø3	
C1	mm	250.0	400.0	210.0	231.0	381.0	92.9	8.5	22.2	34.0	50.0
	inch	9.84	15.75	8.27	9.09	15.00	3.66	0.33	0.87	1.34	1.97

\*D1: Flange mount.

# Frame D

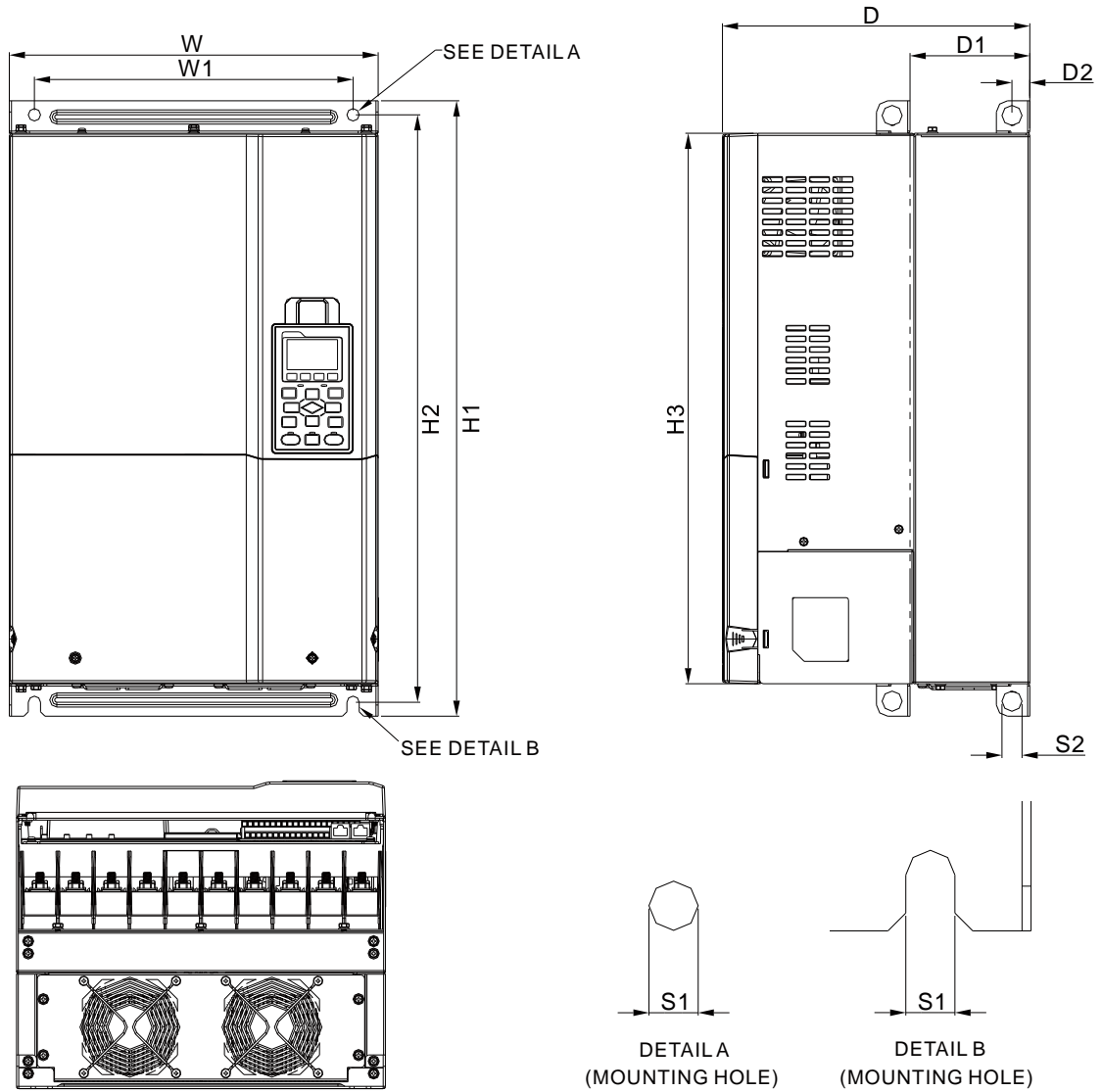

MODEL	FRAME_D1	FRAME_D0-1
VFD300C23A		VFD370C43S
VFD370C23A		VFD450C43S
VFD550C43A		
VFD750C43A		
VFD450C63B-00		
VFD550C63B-00		

Frame	W	H	D	W1	H1	H2	H3	D1*	D2	S1	S2	Ø1	Ø2	Ø3	
D1	mm	330.0	-	275.0	285.0	550.0	525.0	492.0	107.2	16.0	11.0	18.0	-	-	-
	inch	12.99	-	10.83	11.22	21.65	20.67	19.37	4.22	0.63	0.43	0.71	-	-	-
Frame	W	H	D	W1	H1	H2	H3	D1*	D2	S1	S2				
D0-1	mm	280.0	-	255.0	235.0	500.0	475.0	442.0	94.2	16.0	11.0	18.0			
	inch	11.02	-	10.04	9.25	19.69	18.70	17.40	3.71	0.63	0.43	0.71			

\*D1: Flange mount.

## Frame D

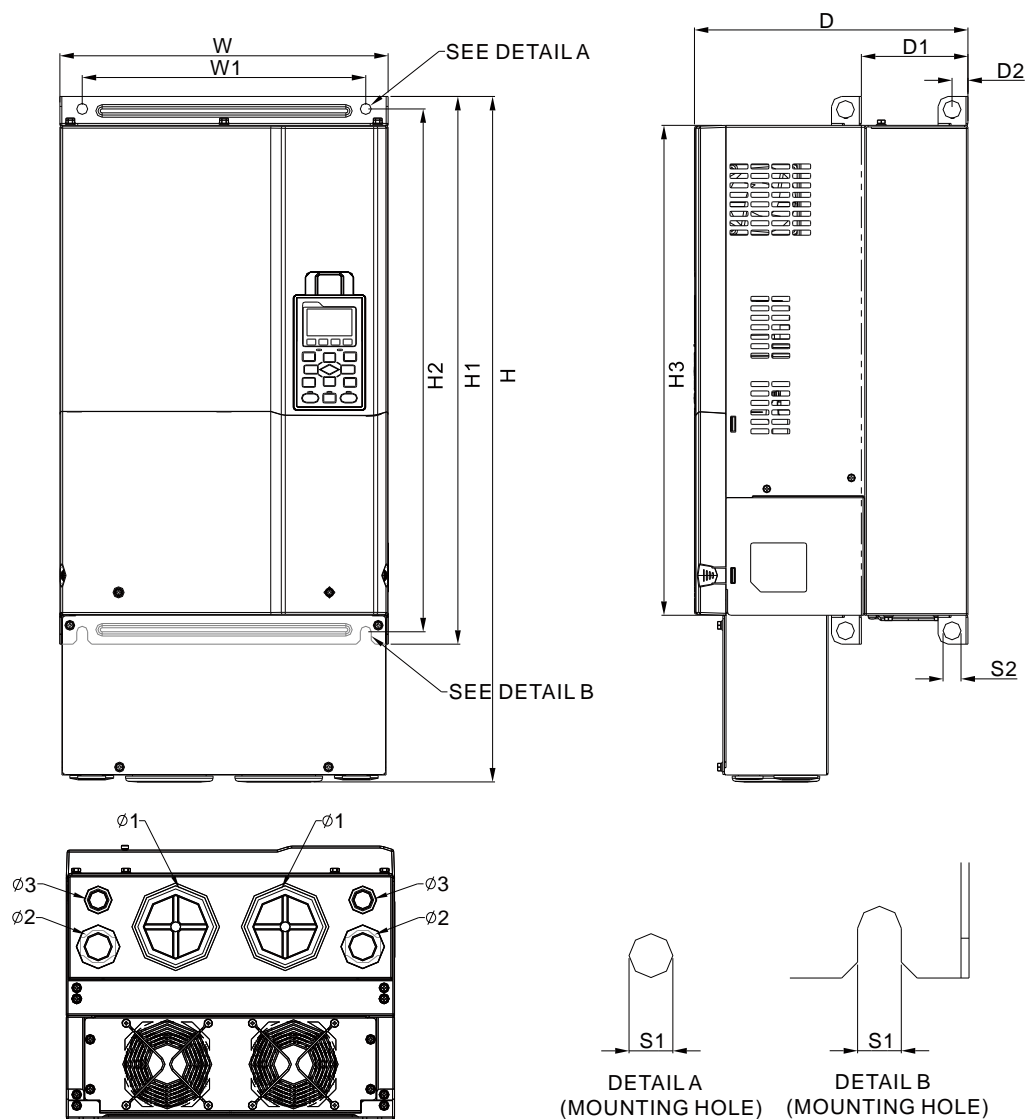

MODEL	FRAME_D2	FRAME_D0-2
VFD300C23E		VFD370C43U
VFD370C23E		VFD450C43U
VFD550C43E		
VFD750C43E		
VFD450C63B-21		
VFD550C63B-21		

Frame	W	H	D	W1	H1	H2	H3	D1*	D2	S1	S2	Ø1	Ø2	Ø3	
D2	mm	330.0	688.3	275.0	285.0	550.0	525.0	492.0	107.2	16.0	11.0	18.0	76.2	34.0	22.0
	inch	12.99	27.10	10.83	11.22	21.65	20.67	19.37	4.22	0.63	0.43	0.71	3.00	1.34	0.87
Frame	W	H	D	W1	H1	H2	H3	D1*	D2	S1	S2	Ø1	Ø2	Ø3	
D0-2	mm	280.0	614.4	255.0	235.0	500.0	475.0	442.0	94.2	16.0	11.0	18.0	62.7	34.0	22.0
	inch	11.02	21.19	10.04	9.25	19.69	18.70	17.40	3.71	0.63	0.43	0.71	2.47	1.34	0.87

\*D1: Flange mount.

# Frame E

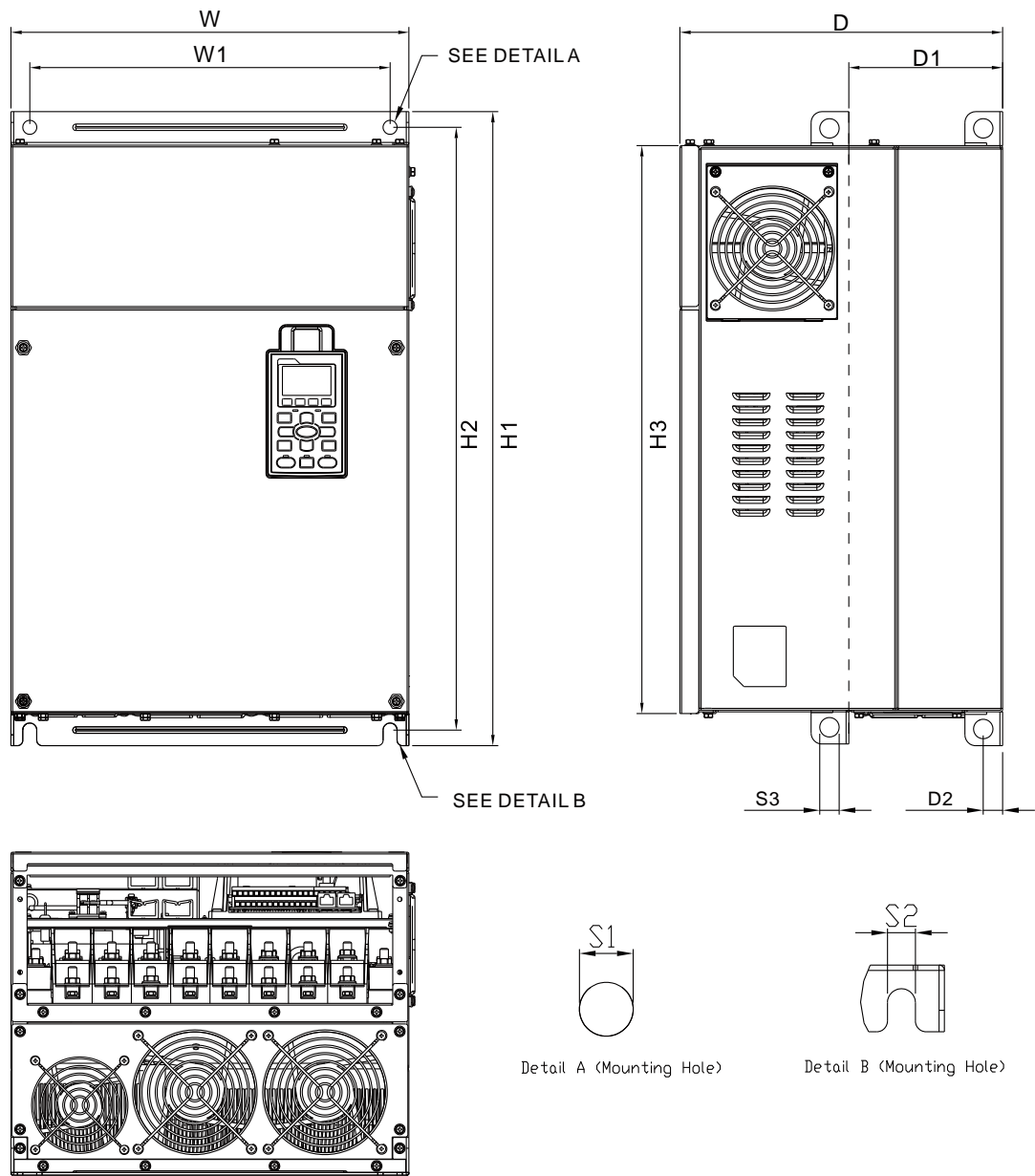

**MODEL  
FRAME\_E1**

VFD450C23A	VFD750C63B-00
VFD550C23A	VFD900C63B-00
VFD750C23A	VFD1100C63B-00
VFD900C43A	VFD1320C63B-00
VFD1100C43A	

Frame		W	H	D	W1	H1	H2	H3	D1*	D2	S1	S2	S3	Ø1	Ø2	Ø3
E1	mm	370.0	-	300.0	335.0	589	560.0	528.0	143.0	18.0	13.0	13.0	18.0	-	-	-
	inch	14.57	-	11.81	13.19	23.19	22.05	20.80	5.63	0.71	0.51	0.51	0.71	-	-	-

\*D1: Flange mount.

# Frame E

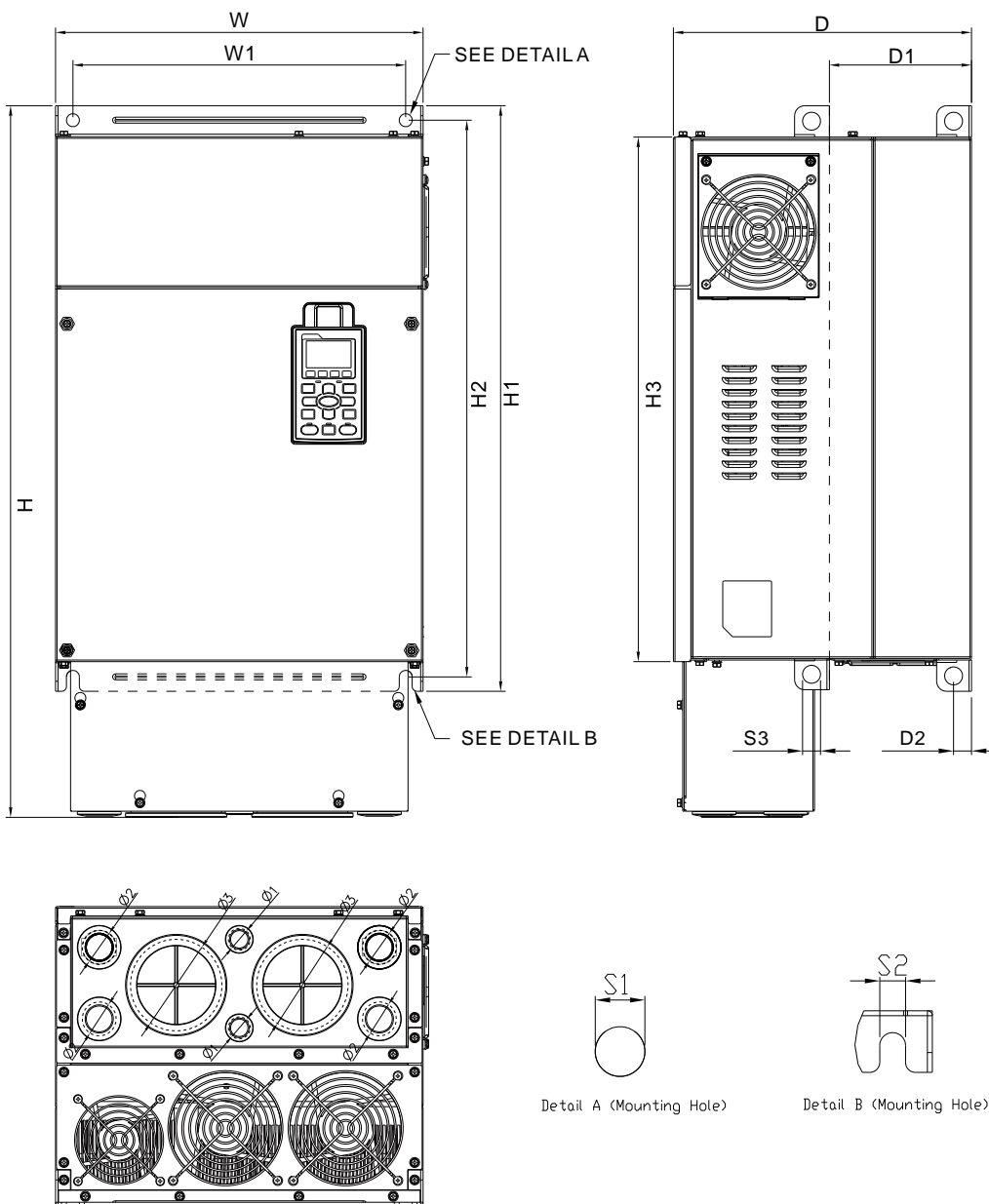

## MODEL FRAME\_E2

VFD450C23E	VFD750C63B-21
VFD550C23E	VFD900C63B-21
VFD750C23E	VFD1100C63B-21
VFD900C43E	VFD1320C63B-21
VFD1100C43E	

Frame	W	H	D	W1	H1	H2	H3	D1*	D2	S1	S2	S3	Ø1	Ø2	Ø3
E2	mm	370.0	715.8	300.0	335.0	589.0	560.0	143.0	18.0	13.0	13.0	18.0	22.0	34.0	92.0
	inch	14.57	28.18	11.81	13.19	23.19	22.05	20.80	5.63	0.71	0.51	0.71	0.87	1.34	3.62

\*D1: Flange mount.

# Frame F

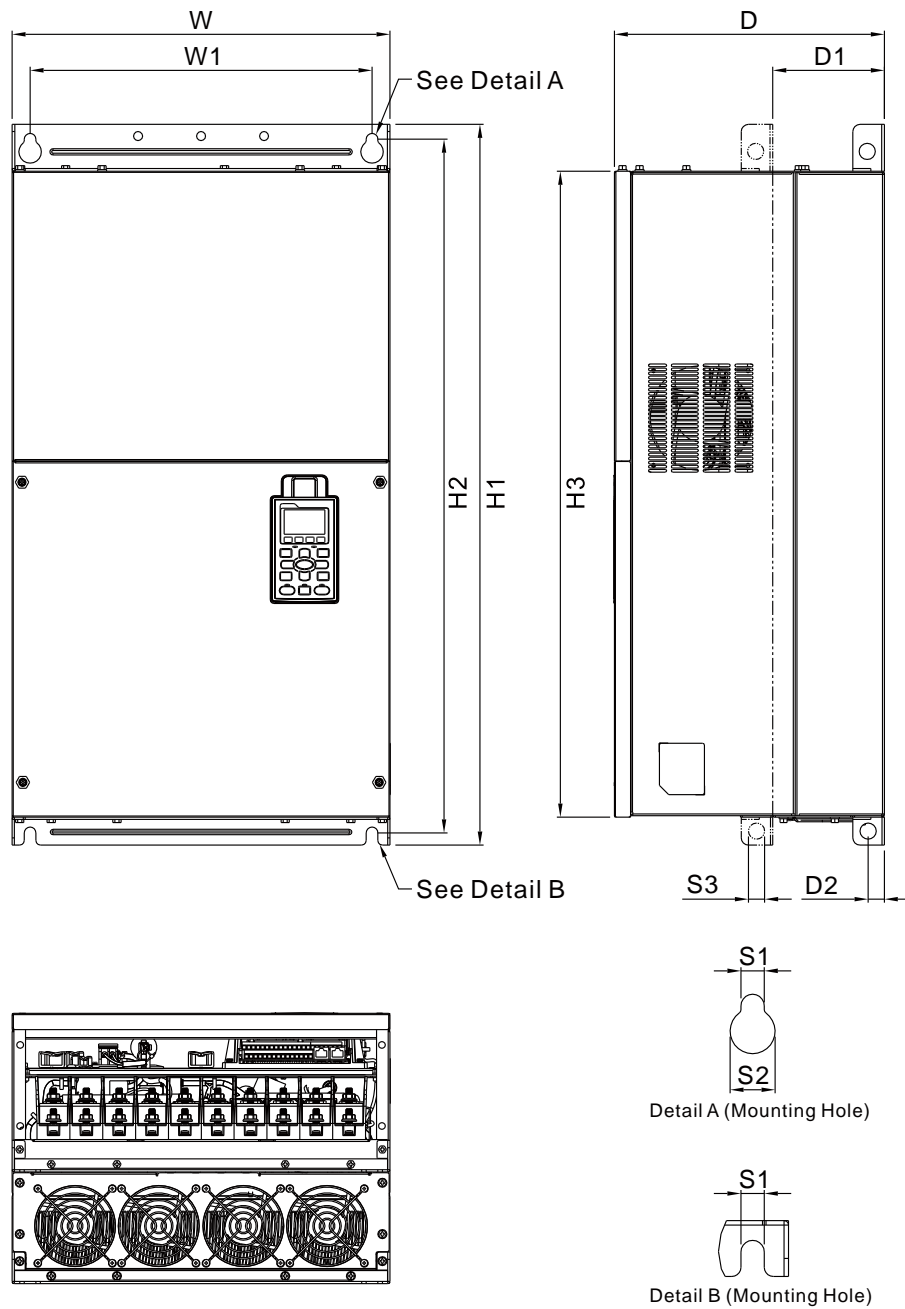

**MODEL**  
**FRAME\_F1**

---

VFD900C23A  
 VFD1320C43A  
 VFD1600C43A  
 VFD1600C63B-00  
 VFD2000C63B-00

Frame	W	H	D	W1	H1	H2	H3	D1*	D2	S1	S2	S3	Ø1	Ø2	Ø3
F1	mm	420.0	-	300.0	380.0	800.0	770.0	124.0	18.0	13.0	25.0	18.0	92.0	35.0	22.0
	inch	16.54	-	11.81	14.96	31.50	30.32	4.88	0.71	0.51	0.98	0.71	3.62	1.38	0.87

\*D1: Flange mount.

# Frame F

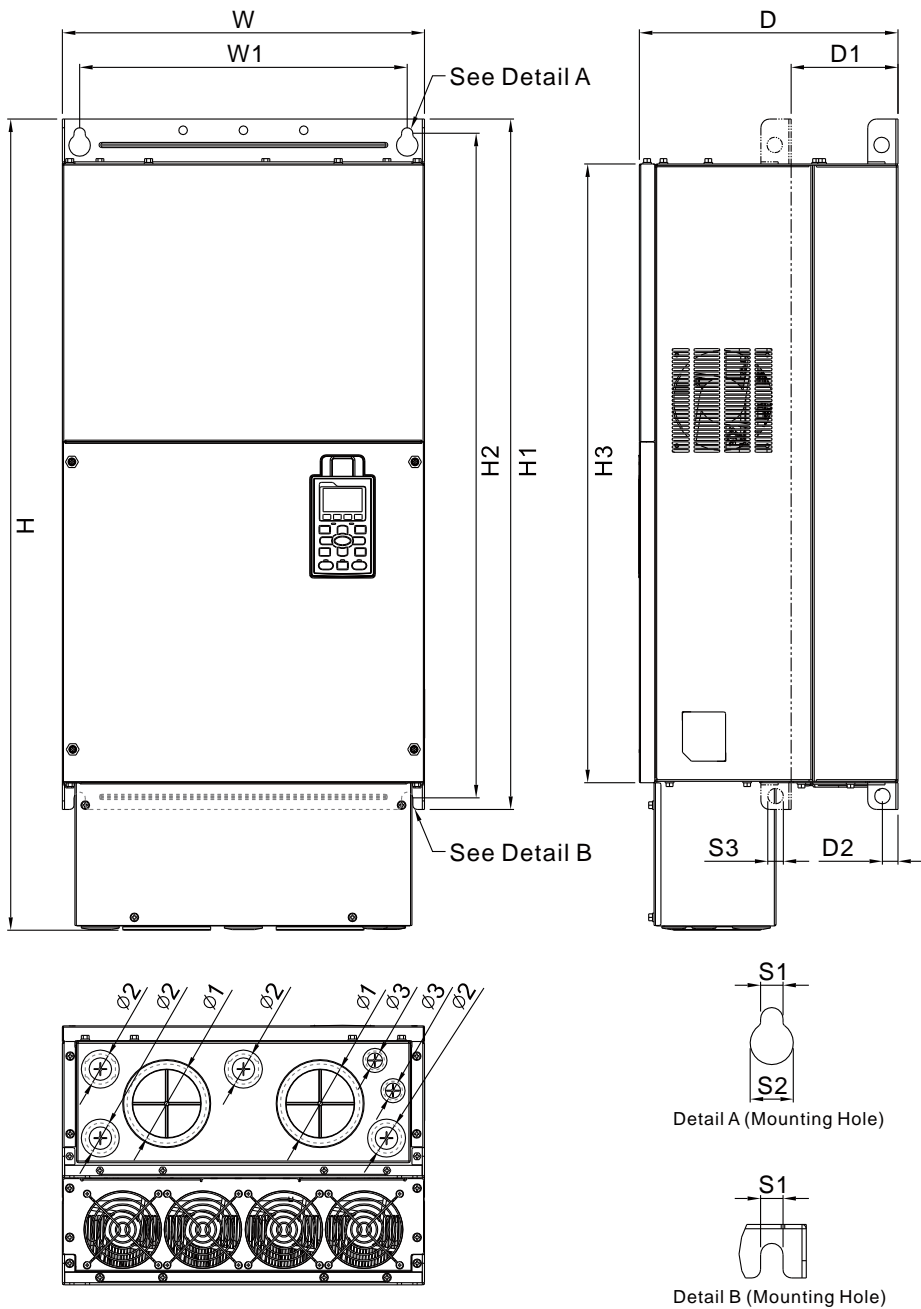

**MODEL**  
**FRAME\_F2**

- VFD900C23E
- VFD1320C43E
- VFD1600C43E
- VFD1600C63B-21
- VFD2000C63B-21

Frame	W	H	D	W1	H1	H2	H3	D1*	D2	S1	S2	S3	Ø1	Ø2	Ø3
F2	mm	420.0	940.0	300.0	380.0	800.0	770.0	124.0	18.0	13.0	25.0	18.0	92.0	35.0	22.0
	inch	16.54	37.00	11.81	14.96	31.50	30.32	28.23	4.88	0.71	0.51	0.98	3.62	1.38	0.87

\*D1: Flange mount.

# Frame G

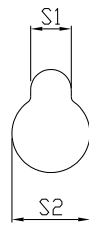
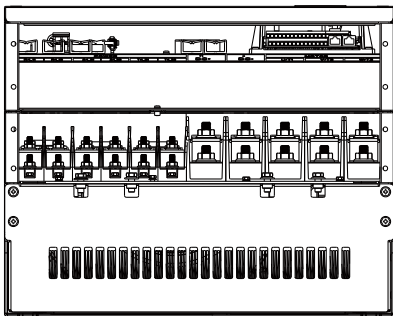
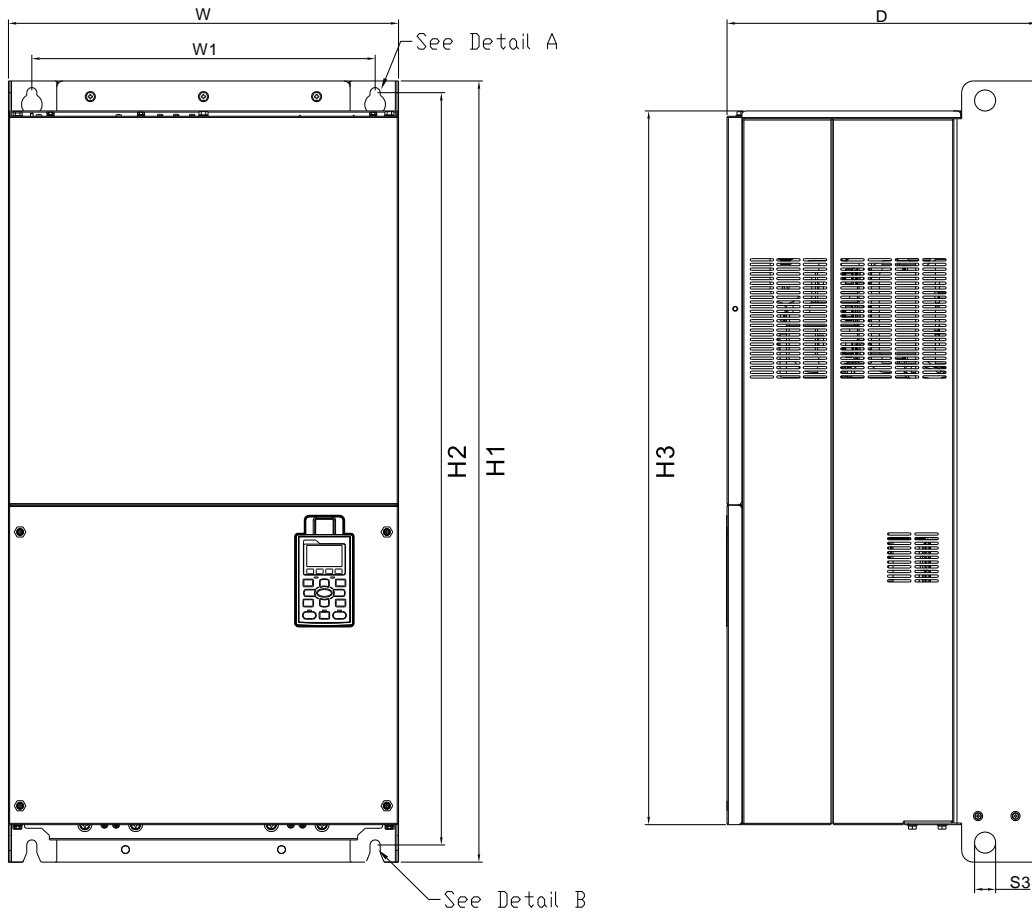

Detail A (Mounting Hole)

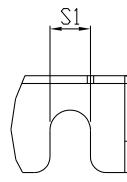

Detail B (Mounting Hole)

**MODEL**  
**FRAME\_G1**

- VFD1850C43A
- VFD2200C43A
- VFD2500C63B-00
- VFD3150C63B-00

Frame	W	H	D	W1	H1	H2	H3	S1	S2	S3	Ø1	Ø2	Ø3	
G1	mm	500.0	-	397.0	440.0	1000.0	963.0	913.6	13.0	26.5	27.0	-	-	-
	inch	19.69	-	15.63	217.32	39.37	37.91	35.97	0.51	1.04	1.06	-	-	-

# Frame G

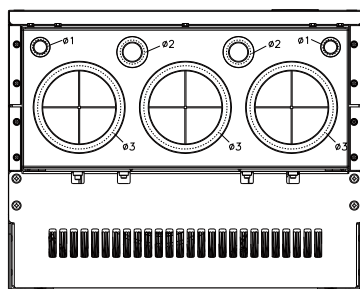
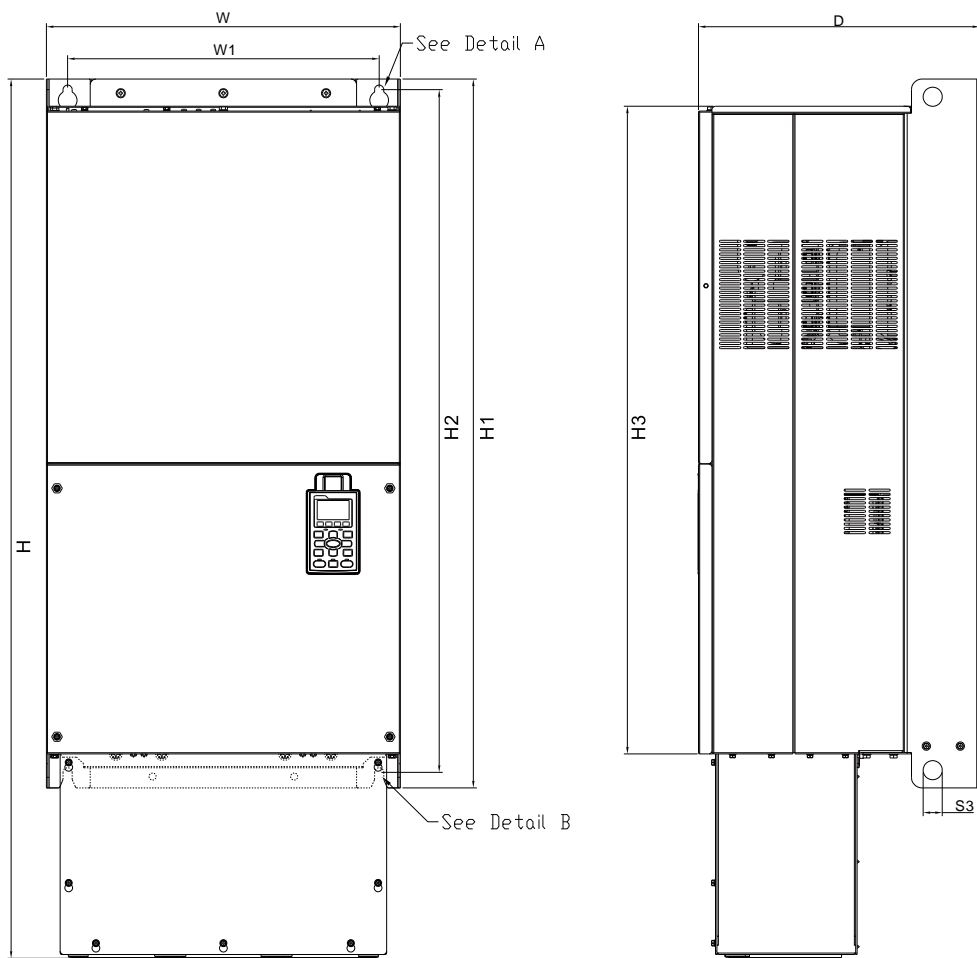

Detail A (Mounting Hole)

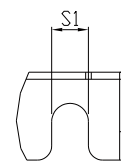

Detail B (Mounting Hole)

## MODEL FRAME\_G2

VFD1850C43E  
VFD2200C43E  
VFD2500C63B-21  
VFD3150C63B-21

Frame		W	H	D	W1	H1	H2	H3	S1	S2	S3	$\varnothing 1$	$\varnothing 2$	$\varnothing 3$
G2	mm	500.0	1240.2	397.0	440.0	1000.0	963.0	913.6	13.0	26.5	27.0	22.0	34.0	117.5
	inch	19.69	48.83	15.63	217.32	39.37	37.91	35.97	0.51	1.04	1.06	0.87	1.34	4.63

# Frame H1

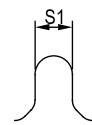
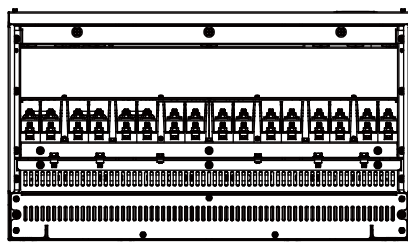
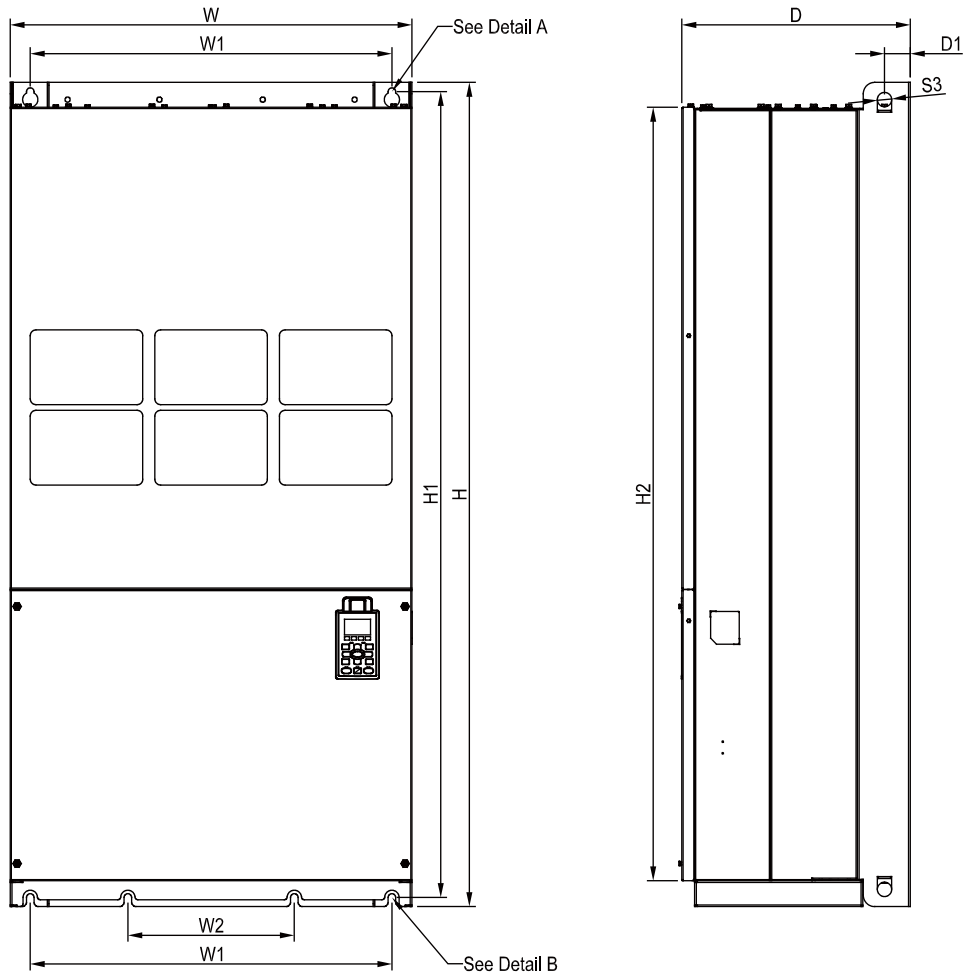

See Detail A (Mounting Hole)

See Detail B (Mounting Hole)

## MODEL FRAME\_H1

VFD2800C43A  
VFD3150C43A  
VFD3550C43A  
VFD4500C43A

Frame	W	H	D	W1	W2	W3	W4	W5	W6	H1	H2	H3	H4
H1	mm	700.0	1435.0	398.0	630.0	290.0	-	-	-	1403.0	1346.6	-	-
	inch	27.56	56.50	15.67	24.80	11.42	-	-	-	55.24	53.02	-	-
Frame	H5	D1	D2	D3	D4	D5	D6	S1	S2	S3	Ø1	Ø2	Ø3
H1	mm	-	45.0	-	-	-	-	13.0	26.5	25.0	-	-	-
	inch	-	1.77	-	-	-	-	0.51	1.04	0.98	-	-	-

# Frame H2

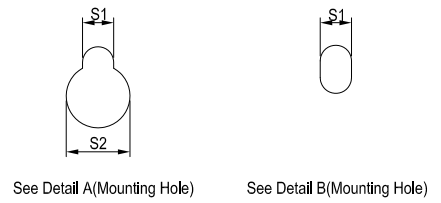
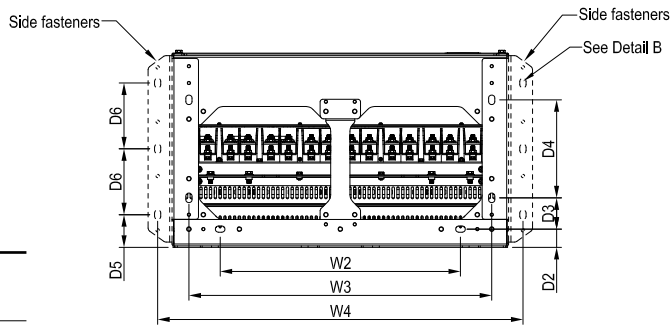
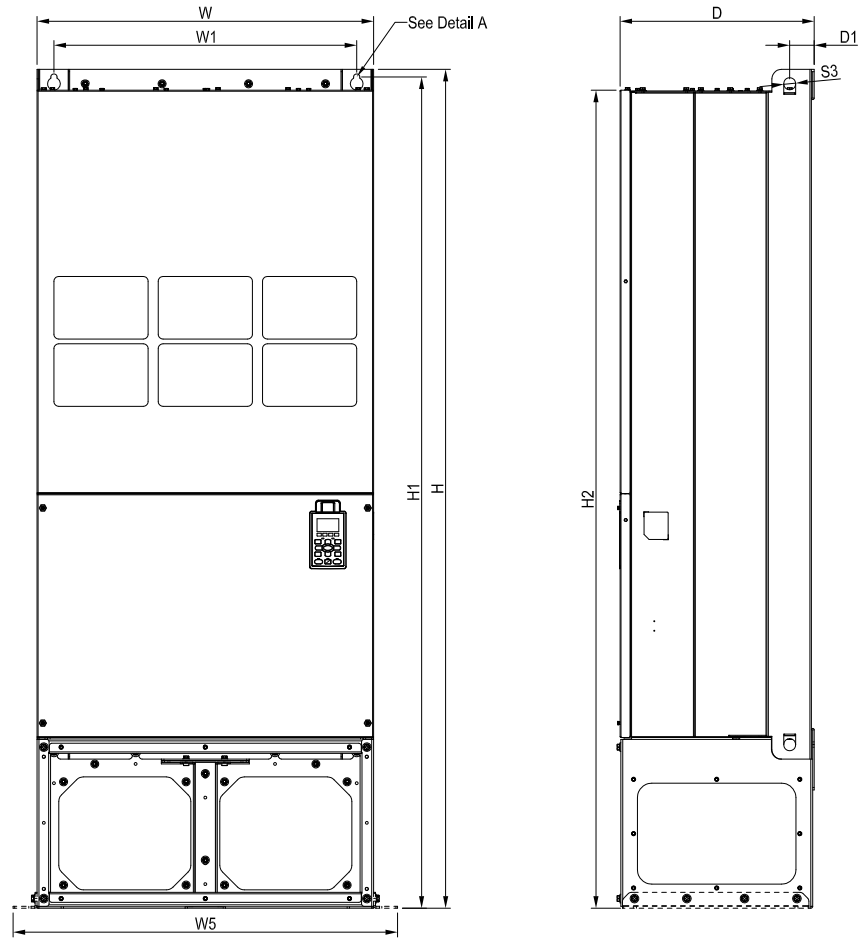

**MODEL**  
**FRAME\_H2**

- VFD2800C43E-1
- VFD3150C43E-1
- VFD3550C43E-1
- VFD4500C43E-1

Frame	W	H	D	W1	W2	W3	W4	W5	W6	H1	H2	H3	H4	
H2	mm	700.0	1745.0	404.0	630.0	500.0	630.0	760.0	800.0	-	1729.0	1701.6	-	-
	inch	27.56	68.70	15.9	24.80	19.69	24.80	29.92	31.50	-	68.07	66.99	-	-
Frame	H5	D1	D2	D3	D4	D5	D6	S1	S2	S3	Ø1	Ø2	Ø3	
H2	mm	-	51.0	38.0	65.0	204.0	68.0	137.0	13.0	26.5	25.0	-	-	
	inch	-	2.0	1.50	2.56	8.03	2.68	5.4	0.51	1.04	0.98	-	-	

# Frame H3

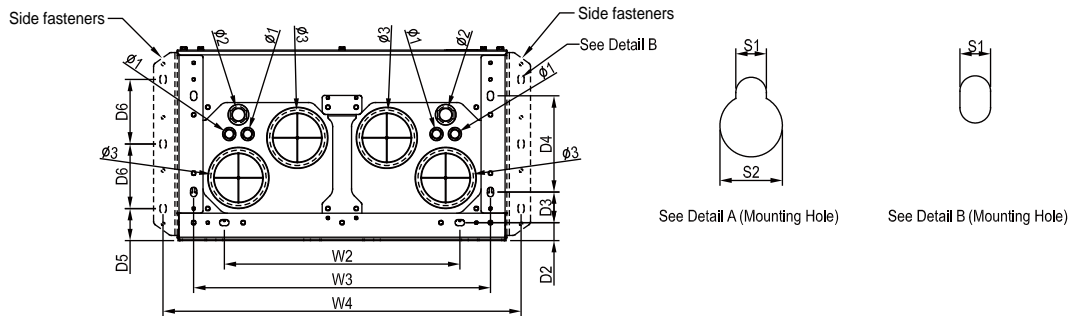
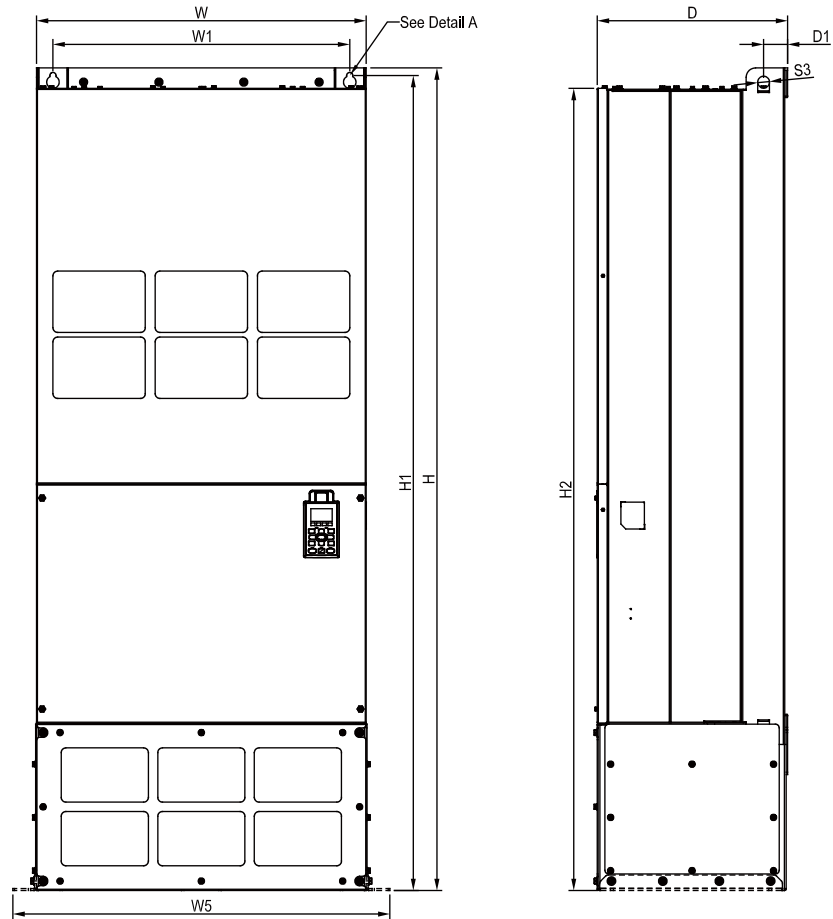

**MODEL**  
**FRAME\_H3**  
VFD2800C43E  
VFD3150C43E  
VFD3550C43E  
VFD4500C43E

Frame	W	H	D	W1	W2	W3	W4	W5	W6	H1	H2	H3	H4	
H3	mm	700.0	1745.0	404.0	630.0	500.0	630.0	760.0	800.0	-	1729.0	1701.6	-	-
	inch	27.56	68.70	15.9	24.80	19.69	24.80	29.92	31.50	-	68.07	66.99	-	-
Frame	H5	D1	D2	D3	D4	D5	D6	S1	S2	S3	Ø1	Ø2	Ø3	
H3	mm	-	51.0	38.0	65.0	204.0	68.0	137.0	13.0	26.5	25.0	22.0	34.0	117.5
	inch	-	2.0	1.50	2.56	8.03	2.68	5.4	0.51	1.04	0.98	0.87	1.34	4.63

# 690 V Frame H1

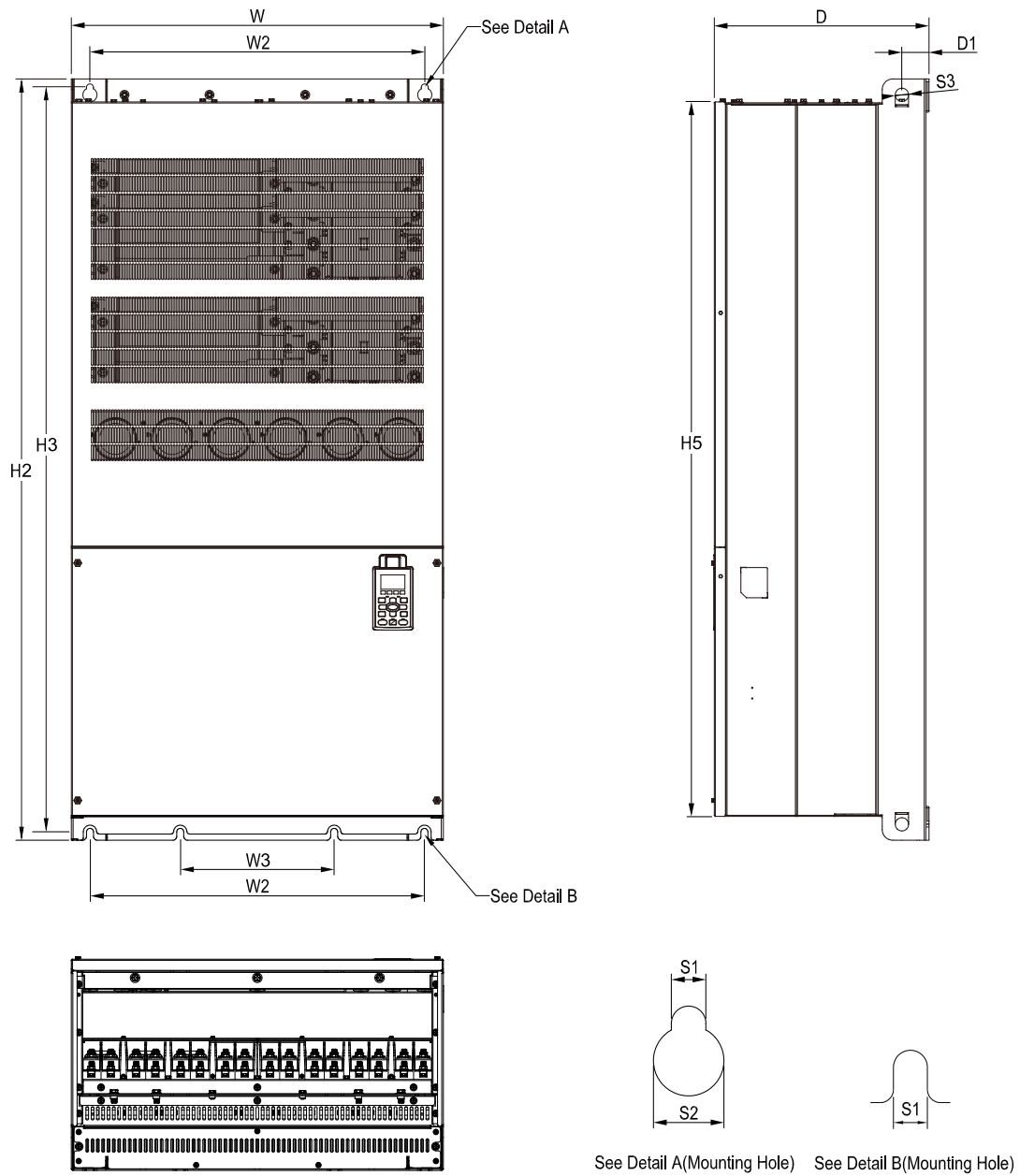

**MODEL**  
**690V FRAME\_H1**

- VFD4000C63B-00
- VFD4500C63B-00
- VFD5600C63B-00
- VFD6300C63B-00

Frame	W	H	D	W1	W2	W3	W4	W5	W6	H1	H2	H3	H4
H1	mm	700.0	-	398.0	-	630.0	290.0	-	-	-	1435.0	1403.0	-
	inch	27.56	-	15.67	-	24.80	11.42	-	-	-	56.50	55.24	-
Frame	H5	D1	D2	D3	D4	D5	D6	S1	S2	S3	Ø1	Ø2	Ø3
H1	mm	1346.6	45.0	-	-	-	-	13.0	26.5	25.0	-	-	-
	inch	53.02	1.77	-	-	-	-	0.51	1.04	0.98	-	-	-

# 690 V Frame H2

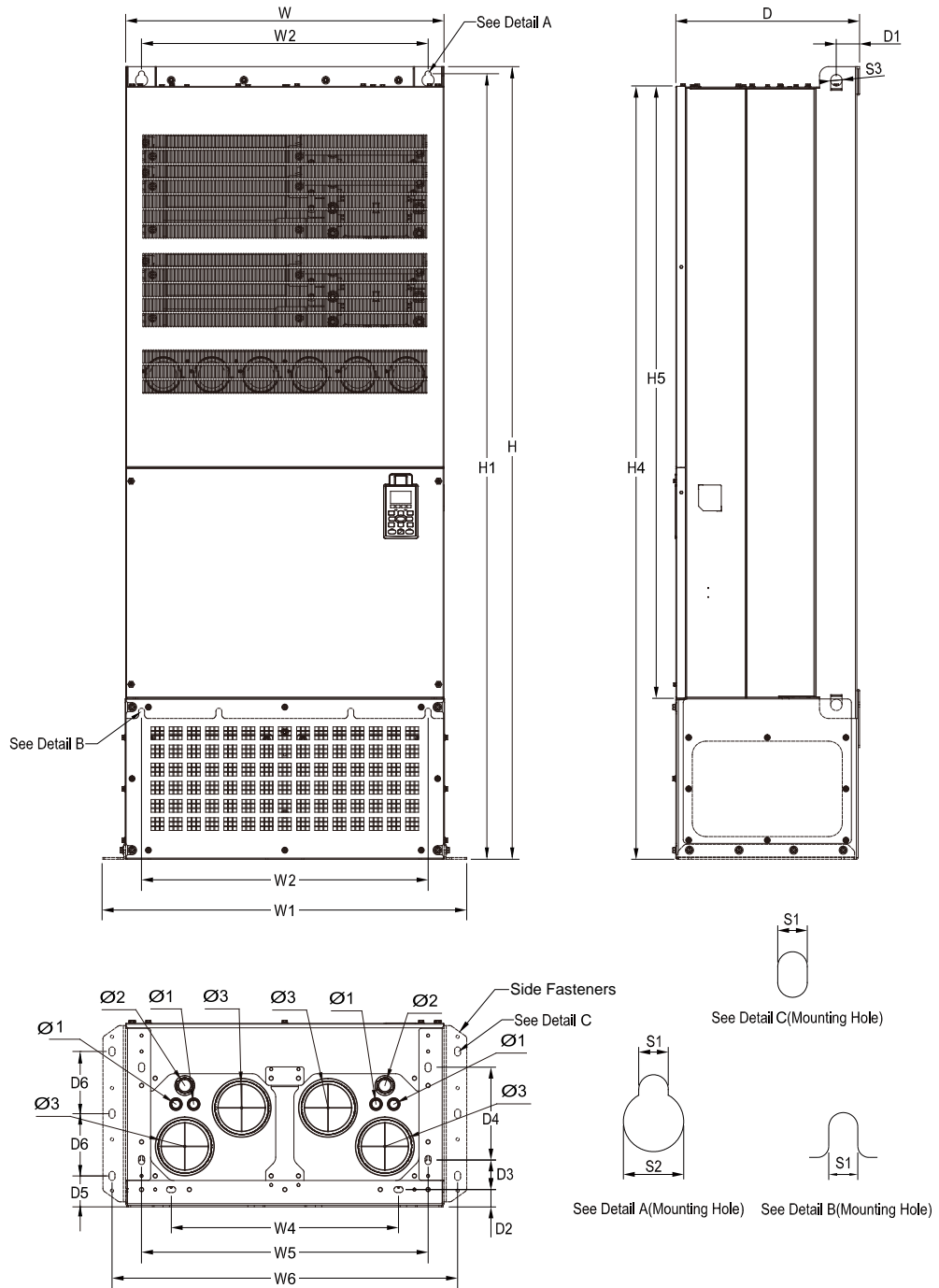

**MODEL**  
**690V FRAME\_H2**

- VFD4000C63B-21
- VFD4500C63B-21
- VFD5600C63B-21
- VFD6300C63B-21

Frame	W	H	D	W1	W2	W3	W4	W5	W6	H1	H2	H3	H4	
H2	mm	700.0	1745.0	404.0	800.0	630.0	-	500.0	630.0	760.0	1729.0	-	-	1701.6
	inch	27.56	68.70	15.91	31.50	24.80	-	19.69	24.80	29.92	68.07	-	-	66.99
Frame	H5	D1	D2	D3	D4	D5	D6	S1	S2	S3	Ø1	Ø2	Ø3	
H2	mm	1346.6	51.0	38.0	65.0	204.0	68.0	137.0	13.0	26.5	25.0	22.0	34.0	117.5
	inch	53.02	2.01	1.50	2.56	8.03	2.68	5.39	0.51	1.04	0.98	0.87	1.34	4.63

# Accessories

## EMC-PG01L / EMC-PG02L



Set by Pr.10-00 ~ 10-02

Terminals		Description
PG1	VP	Output voltage for power: +5V/+12V ± 5% (use FSW3 to switch +5V/+12V) Max. output current: 200mA
	DCM	Common for power and signal
	A1, /A1, B1, /B1, Z1, /Z1	Encoder input signal (Line Driver) Open collector input: +5 V / +24 V (Note1) 1-phase or 2-phase input Max. input frequency: EMC-PG01L: 300KHz; EMC-PG02L: 30KHz
PG2	A2, /A2, B2, /B2	Pulse input signal (Line Driver or Open Collector) Open collector input: +5V/+24V (Note1) 1-phase or 2-phase input Max. input frequency: EMC-PG01L: 300KHz; EMC-PG02L: 30KHz
PG OUT	AO, /AO, BO, /BO, ZO, /ZO, SG	PG card output signals. Division frequency function: 1 ~ 255 times Max. output voltage for Line driver: 5V <sub>DC</sub> Max. output current: 50 mA Max. output frequency: EMC-PG01L: 300KHz; EMC-PG02L: 30KHz SG: The GND of PG card is the same as the host controller or PLC, so a common output signal is attained.

## EMC-PG01O / EMC-PG02O



Set by Pr.10-00 ~ 10-02

Terminals		Description
PG1	VP	Output voltage for power: +5V/+12V ± 5% (use FSW3 to switch +5V/+12V) Max. output current: 200mA
	DCM	Common for power and signal
	A1, /A1, B1, /B1, Z1, /Z1	Encoder input signal (Line Driver or Open Collector) Open collector input: +5V/+24V (Note1) 1-phase or 2-phase input Max. input frequency: EMC-PG01O: 300KHz; EMC-PG02O: 30KHz
PG2	A2, /A2, B2, /B2	Pulse input signal (Line Driver or Open Collector) Open collector input: +5V/+24V (Note1) 1-phase or 2-phase input Max. input frequency: EMC-PG01O: 300KHz; EMC-PG02O: 30KHz
PG OUT	V+, /V-	Needs external power source for PG OUT circuit. Input voltage of power: +12V ~ +24V
	V-	Negative power supply input
	A/O, B/O, Z/O	PG card output signals. Division frequency function: 1 ~ 255 times Add a pull-up resistor to the open collector output signals to avoid signal interferences. [Three pull-up resistors are included in the package (1.8KΩ/1W)] Max. Output current: 20mA Max output frequency: EMC-PG01O: 300KHz; EMC-PG02O: 30KHz

## EMC-PG01R



Set by Pr.10-00 ~ 10-02

Terminals		Description
PG1	R1- R2	Resolver output power 7V <sub>rms</sub> , 10kHz
	S1, S2, S3, S4	Resolver input signal 3.5 ± 0.175V <sub>rms</sub> , 10kHz
PG2	A2, /A2, B2, /B2	Pulse input signal (Line Driver or Open Collector) Open collector input: +5V/+24V (Note1) 1-phase or 2-phase input; Max. input frequency: 300KHz
PG OUT	AO, /AO, BO, /BO, ZO, /ZO, SG	PG card output signals. Division frequency function: 1 ~ 255 times Max. output voltage for Line driver: 5V <sub>DC</sub> Max. output current: 50 mA Max. output frequency: 300 KHz SG: The GND of PG card is the same as the host controller or PLC, so a common output signal is attained.

▪ EMC-PG01U / EMC-PG02U

FJMP1 : Standard UVW Output Encoder; : Delta Encoder



Set by Pr.10-00 ~ 10-02

Terminals	Description
PG1	VP Output voltage for power: +5V/+12V ± 5% (use FSW3 to switch +5V/+12V) Max. output current: 200 mA
	DCM Common for power and signal
	A1, /A1, B1, /B1, Z1, /Z1 Encoder input signal (Line Driver) 1-phase or 2-phase input. Max. input frequency: 300 KHz
	U1, /U1, V1, /V1, W1, /W1 Encoder input signal
PG2	A2, /A2, B2, /B2 Pulse input signal Open collector input: +5V/+24V (Note1) 1-phase or 2-phase input; Max. input frequency: 300KHZ
PG OUT	AO, /AO, BO, /BO, ZO, /ZO, SG PG card output signals. Division frequency function: 1 ~ 255 times Max. output voltage for Line driver: 5 V <sub>DC</sub> Max. output current: 50 mA Max. output frequency: 300 KHz SG: The GND of PG card is the same as the host controller or PLC, so a common output signal is attained.

Note 1: For the Open Collector, set input voltage to 5 ~ 15 mA and install a pull-up resistor  
 [5 V] Recommend pull-up resistor: 100 ~ 220 Ω, 1/2 W and above  
 [12 V] Recommend pull-up resistor: 510 ~ 1.35 KΩ, 1/2 W and above  
 [24 V] Recommend pull-up resistor: 1.8K ~ 3.3 KΩ, 1/2 W and above

▪ EMC-D42A



I/O Extension Card

Terminals	Description
COM	Common for multi-function input terminals Select SINK (NPN)/SOURCE (PNP) in J1 jumper/external power supply
MI10 ~ MI13	Refer to Pr. 02-26 ~ Pr. 02-29 to program the multi-function inputs MI10 ~ MI13. Internal power is applied from terminal E24: +24 V <sub>DC</sub> ± 5% 200 mA, 5 W External power +24 V <sub>DC</sub> : max. voltage 30 V <sub>DC</sub> , min. voltage 19 V <sub>DC</sub> , 30 W ON: the activation current is 6.5 mA; OFF: leakage current tolerance is 10 μA
MO10 ~ MO11	Multi-function output terminals (photocoupler) Duty-cycle: 50%; Max. output frequency: 100 Hz Max. current: 50 mA; Max. voltage: 48 V <sub>DC</sub>
MXM	Common for multi-function output terminals MO10, MO11 (photocoupler) Max 48 V <sub>DC</sub> 50 mA

▪ EMC-D611A



I/O Extension Card

Terminals	Description
AC	AC power common for multi-function input terminal (Neutral)
MI10 ~ MI15	Refer to Pr. 02-26 ~ Pr. 02-31 for multi-function input selection Input voltage: 100 ~ 130 V <sub>AC</sub> ; Input frequency: 57 ~ 63 Hz Input impedance: 27 KΩ Terminal response time: ON: 10 ms; OFF: 20 ms

## EMC-R6AA

	Terminals	Description
 <p><b>Relay Extension Card</b></p>	<p><b>RA10 ~ RA15</b> <b>RC10 ~ RC15</b></p>	<p>Refer to Pr. 02-36 ~ Pr. 02-41 for multi-function output selection</p> <p>Resistive load: 3A (N.O.) / 250 V<sub>AC</sub> 5A (N.O.) / 30 V<sub>DC</sub></p> <p>Inductive load (COS 0.4) 2.0A (N.O.) / 250 V<sub>AC</sub> 2.0A (N.O.) / 30 V<sub>DC</sub></p> <p>It is used to output each monitor signal, such as for drive in operation, frequency attained or overload indication.</p>

## EMC-A22A

	Terminals	Description
 <p><b>Analog I/O extension card</b></p>	<p><b>AVI10</b> <b>AVI11</b></p>	<p>Refer to Pr. 14-00 ~ Pr. 14-01 for function selection (input), and Pr. 14-18 ~ Pr. 14-19 for mode selection.</p> <p>There are two sets of AVI port, SSW3(AVI10) and SSW4(AVI11), which can be switched to AVI or ACI.</p> <p>AVI: Input 0 ~ 10V ACI: Input 0 ~ 20mA / 4 ~ 20mA</p>
	<p><b>AFM10</b> <b>AFM11</b></p>	<p>Refer to Pr. 14-12 ~ Pr. 14-13 for function selection (output), and Pr. 14-36 ~ Pr. 14-37 for mode selection.</p> <p>There are two sets of AFM port, SSW1(AFM10) and SSW2(AFM11), which can be switched to AVO or ACO.</p> <p>AVO: Output 0 ~ 10.00V ACO: Output 0 ~ 20.0mA / 4.0 ~ 20.0mA</p>
	<p><b>ACM</b></p>	<p>Analog signal common terminal</p>

## EMC-BPS01

	Terminals	Description
 <p><b>24V Power Shift Card</b></p>	<p><b>24V GND</b></p>	<p>When the AC motor drive power is off, the external power supply card provides external power to the network system, PLC function, and other functions to allow continued operations.</p> <p>Input power: 24 V<sub>DC</sub> ±5% Maximum input current: 0.5A</p> <p>Note: Do not connect the control terminal +24V (Digital control signal common: SOURCE) directly to the EMC-BPS01 input terminal 24V. Do not connect control terminal GND directly to the EMC-BPS01 input terminal GND.</p>

## ▪ CMC-EIP01

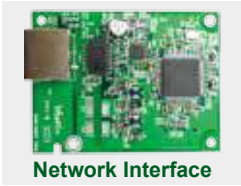

Network Interface

### Features

- ▶ Support EtherNet/IP and MODBUS TCP protocol
- ▶ User-defined parameter mapping
- ▶ IP Filter, basic firewall function

### Network Interface

<b>Interface</b>	RJ-45 with Auto MDI/MDIX	<b>Transmission speed</b>	10/100Mbps Auto-Detect
<b>Number of ports</b>	1 Port	<b>Network protocol</b>	ICMP, IP, TCP, UDP, DHCP, BOOTP, SMTP, EtherNet/IP, Modbus TCP
<b>Transmission method</b>	IEEE 802.3, IEEE 802.3u		
<b>Transmission cable</b>	Category 5e shielding 100 M		

## ▪ CMC-EC01 NEW



### Features

- ▶ Supports EthernetCAT protocol
- ▶ Supports standard CiA402 speed mode
- ▶ Supports SDO (Service Data Objects) function:
  - To write motor drive parameters
  - To read motor drive information
- ▶ Auto shutdown function for interruptions during data transmission

### Network Interface

<b>Interface</b>	RJ-45	<b>Transmission speed</b>	100Mbps
<b>Number of ports</b>	2 Ports	<b>Network protocol</b>	EtherCAT
<b>Transmission method</b>	IEEE 802.3, IEEE 802.3u		
<b>Transmission cable</b>	Category 5e shielding 100M		

## ▪ CMC-PD01



### Features

- ▶ Supports PROFIBUS DP protocol
- ▶ Supports PZD control data exchange
- ▶ Supports PKW polling AC motor drive parameters
- ▶ Supports user diagnosis function
- ▶ Auto-detects baud rates; supports Max. 12Mbps

### PROFIBUS DP Connector

<b>Interface</b>	DB9 connector
<b>Transmission method</b>	High-speed RS-485
<b>Transmission cable</b>	Shielded twisted pair cable
<b>Electrical isolation</b>	500 V <sub>DC</sub>

### Communication

<b>Message type</b>	Cyclic data exchange
<b>Module name</b>	CMC-PD01
<b>GSD document</b>	DELA08DB.GSD
<b>Company ID</b>	08DB (HEX)
<b>Serial transmission speed supported (auto-detection)</b>	9.6 kbps; 19.2 kbps; 93.75 kbps; 187.5 kbps; 125 kbps; 250 kbps; 500 kbps; 1.5 Mbps; 3 Mbps; 6 Mbps; 12 Mbps (bits per second)

## ▪ CMC-DN01

### Features



- ▶ Supports all baud rates on DeviceNet bus: 125 kbps, 250 kbps, 500 kbps and extendable serial transmission speed mode
- ▶ Based on the high-speed communication interface of Delta HSSP protocol, able to conduct immediate control of an AC motor drive
- ▶ Supports Group 2 only connection and polling I/O data exchange
- ▶ For I/O mapping, supports Max. 32 words of input and 32 words of output
- ▶ Supports EDS file configuration in DeviceNet configuration software
- ▶ Node address and serial transmission speed can be set up on AC motor drive
- ▶ Power supplied from AC motor drive

### DeviceNet Connector

<b>Interface</b>	5-Pin 5.08mm pluggable connector
<b>Transmission method</b>	CAN
<b>Transmission cable</b>	Shielded twisted pair cable (with 2 power cables)
<b>Transmission speed</b>	125 kbps, 250 kbps, 500 kbps and extendable serial transmission speed mode
<b>Network protocol</b>	DeviceNet protocol

### DeviceNet Connector

<b>Interface</b>	50 PIN communication terminal
<b>Transmission method</b>	SPI communication
<b>Terminal function</b>	1. Communicating with AC motor drive 2. Transmitting power supply from AC motor drive
<b>Communication protocol</b>	Delta HSSP protocol

## ▪ EMC-COP01

Built-in EMC-COP01 card are available for VFDXXXC23E and VFDXXXC43E

### RJ-45 Pin definition

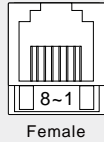
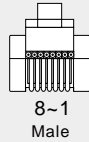

Pin	Pin name	Definition
1	CAN_H	CAN_H bus line (dominant high)
2	CAN_L	CAN_L bus line (dominant low)
3	CAN_GND	Ground/0V/V-
6	CAN_GND	Ground/0V/V-

# Accessories

## Delta Standard Fieldbus Cables

Delta Cables	Part Number	Description	Length
CANopen Cable	UC-CMC003-01A	CANopen cable, RJ45 connector	0.3m
	UC-CMC005-01A	CANopen cable, RJ45 connector	0.5m
	UC-CMC010-01A	CANopen cable, RJ45 connector	1m
	UC-CMC015-01A	CANopen cable, RJ45 connector	1.5m
	UC-CMC020-01A	CANopen cable, RJ45 connector	2m
	UC-CMC030-01A	CANopen cable, RJ45 connector	3m
	UC-CMC050-01A	CANopen cable, RJ45 connector	5m
	UC-CMC100-01A	CANopen cable, RJ45 connector	10m
	UC-CMC200-01A	CANopen cable, RJ45 connector	20m
DeviceNet Cable	UC-DN01Z-01A	DeviceNet cable	305m
	UC-DN01Z-02A	DeviceNet cable	305m
EtherNet Cable	UC-EMC003-02A	EtherNet/EtherCAT cable, Shielding	0.3m
	UC-EMC005-02A	EtherNet/EtherCAT cable, Shielding	0.5m
	UC-EMC010-02A	EtherNet/EtherCAT cable, Shielding	1m
	UC-EMC020-02A	EtherNet/EtherCAT cable, Shielding	2m
	UC-EMC050-02A	EtherNet/EtherCAT cable, Shielding	5m
	UC-EMC100-02A	EtherNet/EtherCAT cable, Shielding	10m
	UC-EMC200-02A	EtherNet/EtherCAT cable, Shielding	20m
CANopen/DeviceNet TAP	TAP-CN01	1 in 2 out, built-in 121Ω terminal resistor	1 in 2 out
	TAP-CN02	1 in 4 out, built-in 121Ω terminal resistor	1 in 4 out
	TAP-CN03	1 in 4 out, RJ45 connector, built-in 121Ω terminal resistor	1 in 4 out
PROFIBUS Cable	UC-PF01Z-01A	PROFIBUS DP cable	305m

Unit: mm

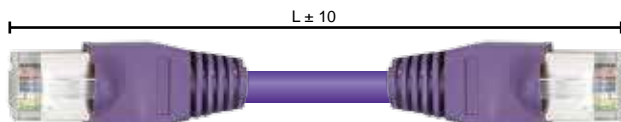

## CANopen Breakout Box

Model: TAP-CN03

Unit: mm [inch]



# Model Name

• 230 V / 460 V:

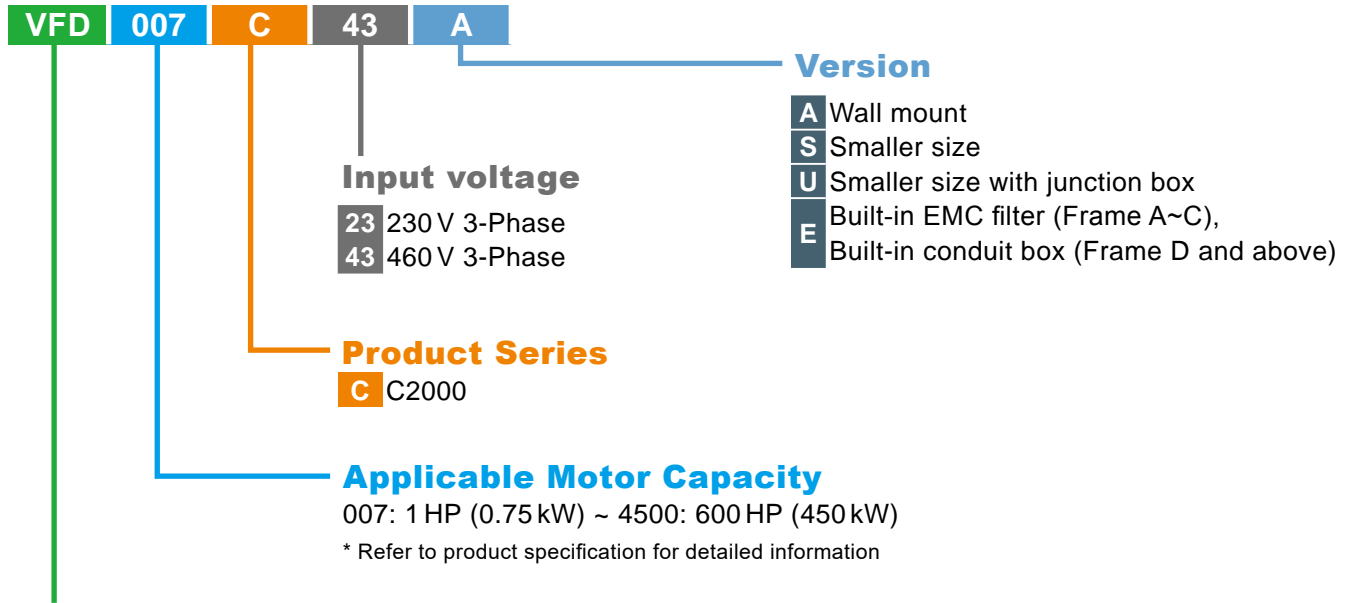

• 575 V / 690 V:

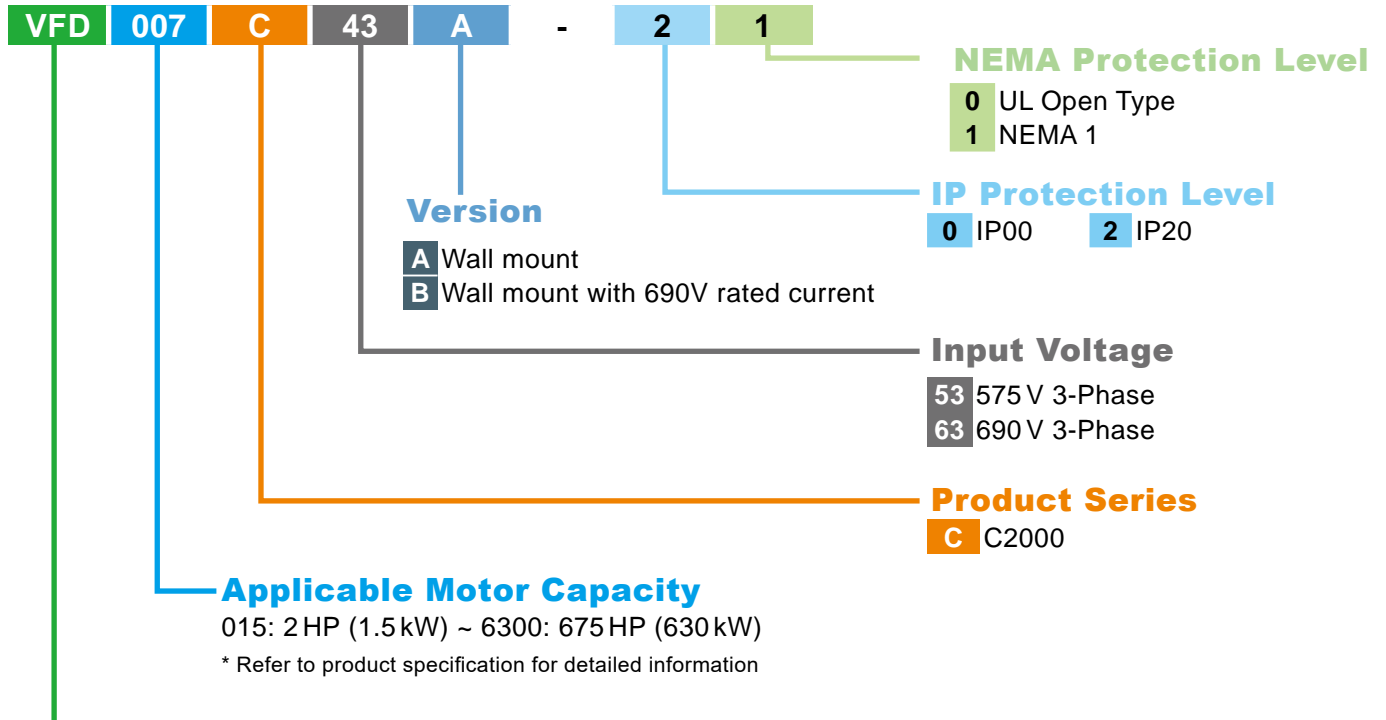

# Ordering Information

Frame Size		Power Range	Models			
<b>Frame A</b>		230 V: 0.75 ~ 3.7 kW  460 V: 0.75 ~ 5.5 kW  575 V: 1.5 ~ 3.7 kW	VFD007C23A VFD015C23A VFD022C23A VFD037C23A	VFD007C43A VFD015C43A VFD022C43A VFD037C43A VFD040C43A VFD055C43A	VFD007C43E VFD015C43E VFD022C43E VFD037C43E VFD040C43E VFD055C43E	VFD015C53A-21 VFD022C53A-21 VFD037C53A-21
<b>Frame B</b>		230 V: 5.5 ~ 11 kW  460 V: 7.5 ~ 15 kW  575 V: 5.5 ~ 15 kW	VFD055C23A VFD075C23A VFD110C23A	VFD075C43A VFD110C43A VFD150C43A	VFD075C43E VFD110C43E VFD150C43E	VFD055C53A-21 VFD075C53A-21 VFD110C53A-21 VFD150C53A-21
<b>Frame C</b>		230 V: 15 ~ 22 kW  460 V: 18.5 ~ 30 kW  690 V: 18.5 ~ 37 kW	VFD150C23A VFD185C23A VFD220C23A	VFD185C43A VFD220C43A VFD300C43A	VFD185C43E VFD220C43E VFD300C43E	VFD185C63B-21 VFD220C63B-21 VFD300C63B-21 VFD370C63B-21
<b>Frame D</b>		230 V: 30 ~ 37 kW  460 V: 37 ~ 75 kW  690 V: 55 ~ 75 kW	<b>Frame_D1</b> VFD300C23A VFD370C23A VFD550C43A VFD750C43A VFD450C63B-00 VFD550C63B-00	<b>Frame_D0-1</b> VFD370C43S VFD450C43S	<b>Frame_D2</b> VFD300C23E VFD370C23E VFD550C43E VFD750C43E VFD450C63B-21 VFD550C63B-21	<b>Frame_D0-2</b> VFD370C43U VFD450C43U
<b>Frame E</b>		230 V: 45 ~ 75 kW  460 V: 90 ~ 110 kW  690 V: 75 ~ 132 kW	<b>Frame_E1</b> VFD450C23A VFD550C23A VFD750C23A VFD900C43A VFD1100C43A VFD750C63B-00 VFD900C63B-00 VFD1100C63B-00 VFD1320C63B-00	<b>Frame_E2</b> VFD450C23E VFD550C23E VFD750C23E VFD900C43E VFD1100C43E VFD750C63B-21 VFD900C63B-21 VFD1100C63B-21 VFD1320C63B-21		
<b>Frame F</b>		230 V: 90 kW  460 V: 132 ~ 160 kW  690 V: 160 ~ 200 kW	<b>Frame_F1</b> VFD900C 23A VFD1320C 43A VFD1600C 43A VFD1600C63B-00 VFD2000C63B-00	<b>Frame_F2</b> VFD900C 23E VFD1320C 43E VFD1600C 43E VFD1600C63B-21 VFD2000C63B-21		

Frame Size		Power Range	Models		
<b>Frame G</b>		460 V: 185 ~ 220 kW  690 V: 250 ~ 315 kW	<b>Frame_G1</b> VFD1850C43A VFD2200C43A VFD2500C63B-00 VFD3150C63B-00	<b>Frame_G2</b> VFD1850C43E VFD2200C43E VFD2500C63B-21 VFD3150C63B-21	
<b>Frame H</b>		460 V: 280 ~ 450 kW	<b>Frame_H1</b> VFD2800C43A VFD3150C43A VFD3550C43A VFD4500C43A	<b>Frame_H2</b> VFD2800C43E-1 VFD3150C43E-1 VFD3550C43E-1 VFD4500C43E-1	<b>Frame_H3</b> VFD2800C43E VFD3150C43E VFD3550C43E VFD4500C43E
<b>Frame H (690 V Model)</b>		690 V: 400 ~ 630 kW	<b>Frame_H1</b> VFD4000C63B-00 VFD4500C63B-00 VFD5600C63B-00 VFD6300C63B-00	<b>Frame_H2</b> VFD4000C63B-21 VFD4500C63B-21 VFD5600C63B-21 VFD6300C63B-21	



# Global Operations

## ASIA (Taiwan)



**Taoyuan Technology Center (Green Building)**



**Taoyuan Plant 1**



**Tainan Plant (Diamond-rated Green Building)**

## ASIA (China)



**Wujiang Plant 3**



**Delta Electronics**



**ASIA (Japan)**



Tokyo Office

**ASIA (India)**



Rudrapur Plant  
(Green Building)

**EUROPE**



Amsterdam, Netherlands

**AMERICA**



Research Triangle Park

▲ Factories 5 ■ Branch Offices 102 ● R&D Centers 6 ■ Distributors 824





Smarter. Greener. Together.

## Industrial Automation Headquarters

### Delta Electronics, Inc.

Taoyuan Technology Center  
No.18, Xinglong Rd., Taoyuan District,  
Taoyuan City 33068, Taiwan  
TEL: 886-3-362-6301 / FAX: 886-3-371-6301

## Asia

### Delta Electronics (Shanghai) Co., Ltd.

No.182 Minyu Rd., Pudong Shanghai, P.R.C.  
Post code : 201209  
TEL: 86-21-6872-3988 / FAX: 86-21-6872-3996  
Customer Service: 400-820-9595

### Delta Electronics (Japan), Inc.

Tokyo Office  
Industrial Automation Sales Department  
2-1-14 Shibadaimon, Minato-ku  
Tokyo, Japan 105-0012  
TEL: 81-3-5733-1155 / FAX: 81-3-5733-1255

### Delta Electronics (Korea), Inc.

Seoul Office  
1511, 219, Gasan Digital 1-Ro., Geumcheon-gu,  
Seoul, 08501 South Korea  
TEL: 82-2-515-5305 / FAX: 82-2-515-5302

### Delta Energy Systems (Singapore) Pte Ltd.

4 Kaki Bukit Avenue 1, #05-04, Singapore 417939  
TEL: 65-6747-5155 / FAX: 65-6744-9228

### Delta Electronics (India) Pvt. Ltd.

Plot No.43, Sector 35, HSIIDC Gurgaon,  
PIN 122001, Haryana, India  
TEL: 91-124-4874900 / FAX : 91-124-4874945

### Delta Electronics (Thailand) PCL.

909 Soi 9, Moo 4, Bangpoo Industrial Estate (E.P.Z),  
Pattana 1 Rd., T.Phraksa, A.Muang,  
Samutprakarn 10280, Thailand  
TEL: 66-2709-2800 / FAX : 662-709-2827

### Delta Energy Systems (Australia) Pty Ltd.

Unit 20-21/45 Normanby Rd., Notting Hill Vic 3168, Australia  
TEL: 61-3-9543-3720

## Americas

### Delta Electronics (Americas) Ltd.

Raleigh Office  
P.O. Box 12173, 5101 Davis Drive,  
Research Triangle Park, NC 27709, U.S.A.  
TEL: 1-919-767-3813 / FAX: 1-919-767-3969

### Delta Greentech (Brasil) S/A

São Paulo Office  
Rua Itapeva, 26 – 3º Andar - Bela Vista  
CEP: 01332-000 – São Paulo – SP - Brasil  
TEL: 55-11-3530-8642 / 55-11-3530-8640

### Delta Electronics International Mexico S.A. de C.V.

Mexico Office  
Vía Dr. Gustavo Baz No. 2160, Colonia La Loma,  
54060 Tlalnepanitla Estado de Mexico  
TEL: 52-55-2628-3015 #3050/3052

## EMEA

### Headquarters: Delta Electronics (Netherlands) B.V.

Sales: Sales.IA.EMEA@deltaww.com  
Marketing: Marketing.IA.EMEA@deltaww.com  
Technical Support: iatechnicalsupport@deltaww.com  
Customer Support: Customer-Support@deltaww.com  
Service: Service.IA.emea@deltaww.com  
TEL: +31(0)40 800 3800

### BENELUX: Delta Electronics (Netherlands) B.V.

De Witbogt 20, 5652 AG Eindhoven, The Netherlands  
Mail: Sales.IA.Benelux@deltaww.com  
TEL: +31(0)40 800 3800

### DACH: Delta Electronics (Netherlands) B.V.

Coesterweg 45, D-59494 Soest, Germany  
Mail: Sales.IA.DACH@deltaww.com  
TEL: +49(0)2921 987 0

### France: Delta Electronics (France) S.A.

ZI du bois Challand 2, 15 rue des Pyrénées,  
Lisses, 91090 Evry Cedex, France  
Mail: Sales.IA.FR@deltaww.com  
TEL: +33(0)1 69 77 82 60

### Iberia: Delta Electronics Solutions (Spain) S.L.U

Ctra. De Villaverde a Vallecas, 265 1º Dcha Ed.  
Hormigueras – P.I. de Vallecas 28031 Madrid  
TEL: +34(0)91 223 74 20

Carrer Llacuna 166, 08018 Barcelona, Spain

Mail: Sales.IA.Iberia@deltaww.com

### Italy: Delta Electronics (Italy) S.r.l.

Ufficio di Milano Via Senigallia 18/2 20161 Milano (MI)  
Piazza Grazioli 18 00186 Roma Italy  
Mail: Sales.IA.Italy@deltaww.com  
TEL: +39 02 64672538

### Russia: Delta Energy System LLC

Vereyskaya Plaza II, office 112 Vereyskaya str.  
17 121357 Moscow Russia  
Mail: Sales.IA.RU@deltaww.com  
TEL: +7 495 644 3240

### Turkey: Delta Greentech Elektronik San. Ltd. Sti. (Turkey)

Şerifaii Mah. Hendem Cad. Kule Sok. No:16-A  
34775 Ümraniye – İstanbul  
Mail: Sales.IA.Turkey@deltaww.com  
TEL: + 90 216 499 9910

### GCC: Delta Energy Systems AG (Dubai BR)

P.O. Box 185668, Gate 7, 3rd Floor, Hamarain Centre  
Dubai, United Arab Emirates  
Mail: Sales.IA.MEA@deltaww.com  
TEL: +971(0)4 2690148

### Egypt + North Africa: Delta Electronics

511 Cairo Business Plaza, North 90 street,  
New Cairo, Cairo, Egypt  
Mail: Sales.IA.MEA@deltaww.com