

# STIHL

## STIHL FS-KM

Instruction Manual





## Contents

KombiSystem	2
Guide to Using this Manual	2
Safety Precautions and Working Techniques	2
Approved KombiEngines	10
Approved Combinations of Cutting Attachment, Deflector, Handle and Harness	11
Mounting the KombiTool	13
Mounting the Deflector	13
Mounting the Cutting Attachment	14
Fitting the Harness	17
Balancing the Machine	19
Starting / Stopping the Engine	19
Transporting the Unit	20
Lubricating the Gearbox	22
Storing the Machine	23
Sharpening Metal Cutting Blades	23
Maintaining the Mowing Head	24
Maintenance and Care	25
Main Parts	26
Specifications	27
Maintenance and Repairs	29
Disposal	29
EC Declaration of Conformity	29

Dear Customer,

Thank you for choosing a quality engineered STIHL product.

It has been built using modern production techniques and comprehensive quality assurance. Every effort has been made to ensure your satisfaction and trouble-free use of the product.

Please contact your dealer or our sales company if you have any queries concerning this product.

Your



Dr. Nikolas Stihl

# STIHL

## KombiSystem

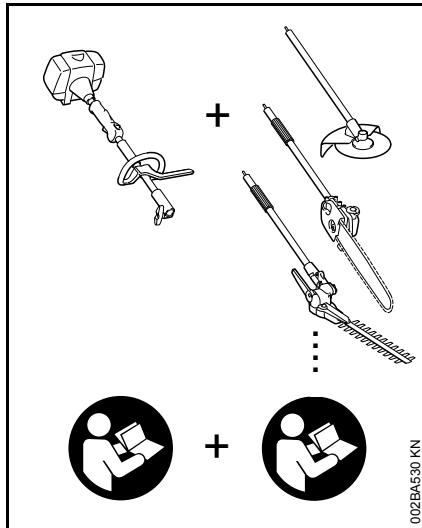

In the STIHL KombiSystem a number of different KombiEngines and KombiTools can be combined to produce a power tool. In this instruction manual the functional unit formed by the KombiEngine **and** KombiTool is referred to as the power tool.

Therefore, the separate instruction manuals for the KombiEngine and KombiTool should be used together for the power tool.

Always read and and make sure you understand **both** instruction manuals before using your power tool for the first time and keep them in a safe place for future reference.

## Guide to Using this Manual

### Pictograms

All the pictograms attached to the machine are shown and explained in this manual.

### Symbols in text



#### WARNING

Warning where there is a risk of an accident or personal injury or serious damage to property.



#### NOTICE

Caution where there is a risk of damaging the machine or its individual components.

### Engineering improvements

STIHL's philosophy is to continually improve all of its products. For this reason we may modify the design, engineering and appearance of our products periodically.

Therefore, some changes, modifications and improvements may not be covered in this manual.

## Safety Precautions and Working Techniques



Some special safety precautions must be observed to reduce the risk of personal injury when operating this power tool because of the very high speed and sharpness of its cutting attachment.



Always read and make sure you understand both instruction manuals (KombiEngine and KombiTool) before using your power tool for the first time and keep them in a safe place for future reference. Non-observance of the safety precautions may result in serious or even fatal injury.

Lend or rent your machine only to persons who are familiar with this model and its operation – do not lend or rent your machine without the KombiEngine and KombiTool instruction manuals.

Depending on the cutting attachment fitted, use your power tool only for cutting grass, wild growth, shrubs, scrub, bushes, small diameter trees and similar materials.

Do not use your power tool for any other purpose because of the **increased risk of accidents**.

Only use cutting attachments and accessories that are explicitly approved for this power tool model by STIHL or

are technically identical. If you have any questions in this respect, consult a servicing dealer.

Use only high quality tools and accessories in order to avoid the risk of accidents and damage to the machine.

STIHL recommends the use of original STIHL tools, cutting attachments and accessories. They are specifically designed to match the product and meet your performance requirements.

The deflector on this power tool cannot protect the operator from all objects thrown by the cutting attachment (stones, glass, wire, etc.). Such objects may ricochet and then hit the operator.

Never attempt to modify your machine in any way since this may increase the risk of personal injury. STIHL excludes all liability for personal injury and damage to property caused while using unauthorized attachments.

Do not use a pressure washer to clean the unit. The solid jet of water may damage parts of the unit.

### Clothing and Equipment

Wear proper protective clothing and equipment.



Clothing must be sturdy but allow complete freedom of movement. Wear snug-fitting clothing, an overall and jacket combination, do not wear a work coat.

Avoid clothing that could get caught on branches or brush or moving parts of the machine. Do not wear a scarf, necktie or jewelry. Tie up and confine long hair (e.g. with a hair net, cap, hard hat, etc.).



Wear steel-toed safety boots with non-slip soles.

Sturdy shoes with non-slip soles may be worn as an alternative only when using mowing heads.



### **WARNING**



To reduce the risk of eye injuries, wear close-fitting safety glasses in accordance with European Standard EN 166. Make sure the safety glasses are a snug fit.

Wear a face shield and make sure it is a good fit. A face shield alone does not provide adequate eye protection.

Wear hearing protection, e.g. earplugs or ear muffs.

Wear a safety hard hat for thinning operations, when working in high scrub and where there is a danger of head injuries from falling objects.



Wear heavy-duty work gloves made of durable material (e.g. leather).

STIHL offers a comprehensive range of personal protective clothing and equipment.

### Transporting the Power Tool

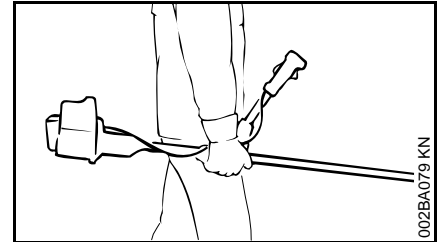
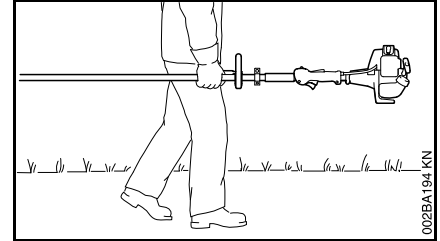

Always turn off the engine.

Carry the unit hanging from the shoulder strap or properly balanced by the drive tube.

To reduce the risk of cut injuries, fit transport guard on the cutting attachment, even when carrying the tool for short distances – see also "Transporting the Unit".



**To reduce the risk of serious burn injuries,** avoid touching hot parts of the machine, including the gearbox housing.

Transporting by vehicle: Properly secure your power tool to prevent turnover, fuel spillage and damage.

## Before Starting

Check that your power tool is properly assembled and in good condition – refer to appropriate chapters in the KombiEngine and KombiTool instruction manuals.

- Use only an approved combination of cutting attachment, deflector, handle and harness. All parts must be assembled properly and securely.
- Check cutting attachment for correct and secure assembly and good condition.
- Check protective devices (e.g. deflector for cutting attachment, rider plate) for damage or wear. Always replace damaged parts. Do not operate your machine with a damaged deflector or worn rider plate (lettering and arrows no longer legible).
- Never attempt to modify the controls or safety devices – work only with a properly mounted deflector.
- Keep the handles dry and clean – free from oil and dirt – for safe control of the power tool.
- Adjust the harness and handle(s) to suit your height and reach. See chapter on "Fitting the Harness".

**To reduce the risk of accidents**, do not operate your power tool if it is damaged or not properly assembled.

If you use a shoulder strap or full harness: Practice removing and putting down the machine as you would in an

emergency. To avoid damage, do not throw the power tool to the ground when practicing.

## Holding and Controlling the Power Tool

Always hold the power tool firmly with both hands on the handles.

Make sure you always have good balance and secure footing.

### Models with bike handle

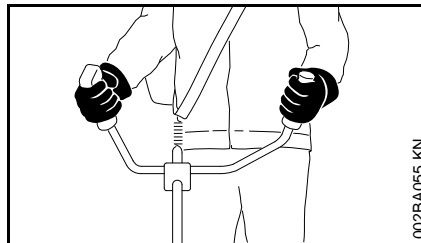

Right handle on control handle, left hand on left handle.

### Models with loop handle

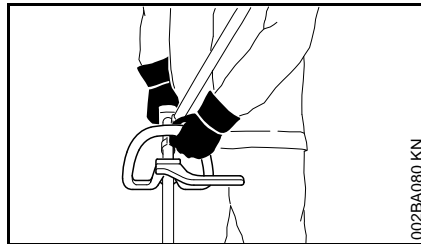

On models with a loop handle and barrier bar, left hand on loop handle, right hand on control handle, even if you are left-handed.

Wrap fingers and thumbs firmly around the handles.

## During Operation

Make sure you always have good balance and secure footing.

In the event of impending danger or in an emergency, switch off the engine immediately by moving the slide control / stop switch/button to **0** or **STOP**.

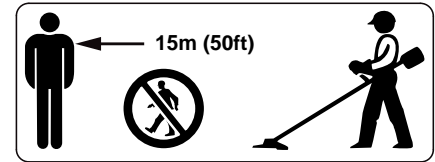

The cutting attachment may catch and fling objects a great distance and cause injury - therefore, do not allow any other persons within a radius of 15 meters of your own position. **To reduce the risk of damage to property**, also maintain this distance from other objects (vehicles, windows). Even maintaining a distance of 15 meters or more cannot exclude the potential danger.



**To reduce the risk of injury**, avoid contact with the cutting attachment.

The correct engine idle speed is important to ensure that the cutting attachment stops rotating when you let go of the throttle trigger.

Check and correct the idle speed setting regularly. If the attachment still rotates when the engine is idling, have your dealer check your machine and make proper adjustments or repairs – see

KombiEngine instruction manual. STIHL recommends an authorized STIHL servicing dealer.

**Take special care in slippery conditions** (ice, wet ground, snow) – on slopes or uneven ground.

Watch out for obstacles: Roots and tree stumps which **could cause you to trip or stumble**.

Always stand on the ground while working, never on a ladder, work platform or any other insecure support.

Never operate your power tool with one hand.

Be particularly alert and cautious when wearing hearing protection because your ability to hear warnings (shouts, alarms, etc.) is restricted.

**To reduce the risk of accidents**, take a break in good time to avoid tiredness or exhaustion.

Work calmly and carefully – in daylight conditions and only when visibility is good. Stay alert so as not to endanger others.

If your power tool is subjected to unusually high loads for which it was not designed (e.g. heavy impact or a fall), always check that it is in good condition before continuing work – see also "Before Starting".

Make sure the safety devices are working properly. Do not continue operating your power tool if it is damaged. In case of doubt, consult your servicing dealer.



**To reduce the risk of injury** from thrown objects, never operate the power tool without the proper deflector for the type of cutting attachment being used.



Inspect the work area: Stones, pieces of metal or other solid objects may be thrown more than 15 meters and **cause personal injury** or damage the cutting attachment and property (e.g. parked vehicles, windows).



Special care must be taken when working in difficult, over-grown terrain.

When cutting high scrub, under bushes and hedges: Keep cutting attachment at a minimum height of 15 cm to avoid harming small animals.

Check the cutting attachment at regular short intervals during operation or immediately if there is a noticeable change in cutting behavior:

- Turn off the engine. Hold the unit firmly and press the cutting attachment into the ground to bring it to a standstill.
- Check condition and tightness, look for cracks.
- Check sharpness.
- Replace damaged or dull cutting attachments immediately, even if they have only superficial cracks.

Clean grass and plant residue off the cutting attachment mounting at regular intervals – remove any build up of material from the cutting attachment and deflector.

**To reduce the risk of injury**, shut off the engine before changing the cutting attachment.



The gearbox becomes hot during operation. **To reduce the risk of burn injury**, do not touch the gearbox housing.

### When using mowing heads

Equip the deflector with the additional components specified in the instruction manual.

Use only the deflector with properly mounted line limiting blade to ensure the mowing lines are automatically trimmed to the approved length.

**To reduce the risk of injury**, always turn off the engine before adjusting the nylon line of manually adjustable mowing heads

Using the unit with over-long nylon cutting lines reduces the motor's operating speed. The clutch then slips continuously and this causes overheating and damage to important components (e.g. clutch, polymer housing components) – **and this can increase the risk of injury** from the cutting attachment rotating while the engine is idling.

## Using metal cutting attachments

STIHL recommends the use of original STIHL metal cutting attachments. They are specifically designed to match your model and meet your performance requirements.

Metal cutting attachments rotate at very high speed. The forces that occur act on the machine, the attachment and the material being cut.

Sharpen metal cutting attachments regularly as specified.

Unevenly sharpened metal cutting attachments cause out-of-balance which can impose extremely high loads on the machine and increase the **risk of breakage**.

Dull or improperly sharpened cutting edges can put a higher load on the cutting attachment and increase the **risk of injury** from cracked or broken parts.

Inspect metal cutting attachments for cracks or warping after every contact with hard objects (e.g. stones, rocks, pieces of metal). **To reduce the risk of injury**, remove burrs and other visible build-ups of material (use a file) because they may become detached and be thrown at high speed during operation.

If a rotating metal cutting attachment makes contact with a rock or other solid object there is a risk of sparking which may cause easily combustible material to catch fire under certain circumstances. Dry plants and scrub are also easily combustible, especially in hot and dry weather conditions. If there is a risk of fire, do not use metal cutting attachments near combustible

materials, dry plants or scrub. Always contact your local forest authority for information on a possible fire risk.

Do not continue using or attempt to repair damaged or cracked cutting attachments by welding, straightening or modifying the shape (out of balance).

This may cause parts of the cutting attachment to come off and hit the operator or bystanders at high speed and **result in serious or fatal injuries**.

To reduce the above-mentioned risks when using a metal cutting attachment, never use a metal cutting attachment with a diameter larger than specified. It must not be too heavy. It must be manufactured from materials of adequate quality and its geometry must be correct (shape, thickness).

**To reduce the risk of injury**, a metal cutting attachment not manufactured by STIHL must not be heavier, thicker, have a different shape or a diameter larger than the largest metal cutting attachment approved by STIHL for this power tool model.

## After Finishing Work

After finishing work or before leaving the unit unattended: Shut off the engine.

After finishing work, clean dirt, soil and plant residue off the cutting attachment – **wear gloves to reduce the risk of injury**.

Do not use grease solvents for cleaning.

After thoroughly cleaning, coat surface of metal cutting attachments with a corrosion inhibitor.

## Maintenance and Repairs

Service the machine regularly. Do not attempt any maintenance or repair work not described in the KombiTool and KombiEngine instruction manuals. Have all other work performed by a servicing dealer.

STIHL recommends that you have servicing and repair work carried out exclusively by an authorized STIHL servicing dealer. STIHL dealers are regularly given the opportunity to attend training courses and are supplied with the necessary technical information.

Only use high-quality replacement parts in order to avoid the risk of accidents and damage to the machine. If you have any questions in this respect, consult a servicing dealer.

STIHL recommends the use of genuine STIHL replacement parts. They are specifically designed to match your model and meet your performance requirements.

To reduce the risk of injury, **always shut off the engine** before carrying out any maintenance or repairs or cleaning the machine.

## Symbols on Deflectors

An **arrow** on the deflector shows the correct direction of rotation of the cutting attachments.

Some of the following symbols are applied to the outside of the deflector to indicate the approved combination of cutting attachment and deflector.





Deflector may be used with mowing heads.



Deflector must not be used with mowing heads.



Deflector may be used with grass cutting blades.



Deflector must not be used with grass cutting blades.



Deflector may be used with brush knives.



Deflector must not be used with brush knives.



Deflector must not be used with shredder blades.



Deflector must not be used with circular saw blades.

### Harness / Strap

The harness is included in the scope of supply or available as a special accessory.

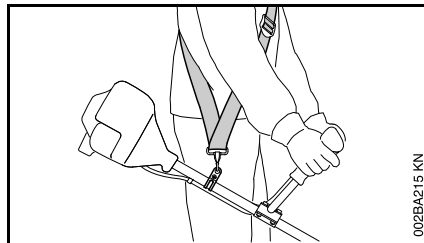

- Use a shoulder strap.
- With the engine running, attach the machine to the shoulder strap.

**Grass cutting blades and brush knives** must always be used in combination with a shoulder strap.

**Circular saw blades** must always be used in combination with a full harness with a quick-release system.

### Mowing Head with Nylon Line

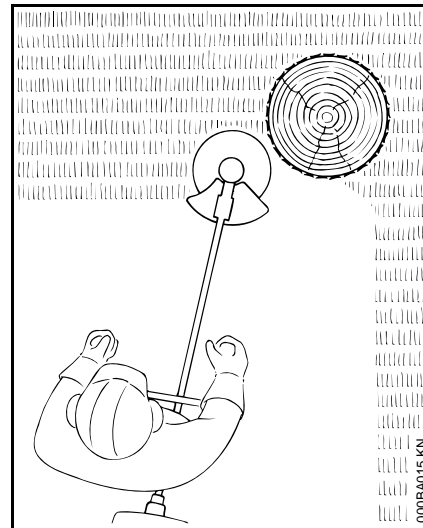

Nylon line achieves a soft cut for edging and trimming around trees, fence posts, etc. – less risk of damaging tree bark.

The mowing head comes with an instruction leaflet. Refill the mowing head with nylon line as described in the instruction leaflet.

### **! WARNING**

To reduce the risk of serious injury, never use wire or metal-reinforced line in place of the nylon line.

### STIHL Polycut Mowing Head with Polymer Blades

For mowing unobstructed edges of meadows (without posts, fences, trees or similar obstacles).

### Check the wear limit marks!

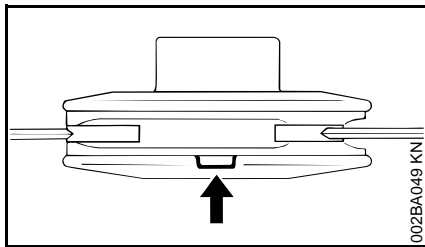

If one of the wear limit marks on the PolyCut mowing head is worn through (arrow): Do not continue using the mowing head. Install a new one. There is otherwise a **risk of injury** from thrown parts of the head.

It is important to follow the maintenance instructions for the PolyCut mowing head.

The PolyCut can also be equipped with mowing line in place of the polymer blades.

The mowing head comes with instruction leaflets. Equip the mowing head with polymers blades or nylon line as described in the instruction leaflets.

### WARNING

Never use wire in place of the nylon mowing line – **risk of injury**.

### Risk of Kickout (Blade Thrust) with Metal Cutting Attachments

### WARNING



When using metal cutting attachments there is a risk of kickout when the rotating blade comes into contact with a solid object such as a tree trunk, branch, tree stump, rock or similar. The machine is thrown to the right or to the rear – opposite to the attachment's direction of rotation.

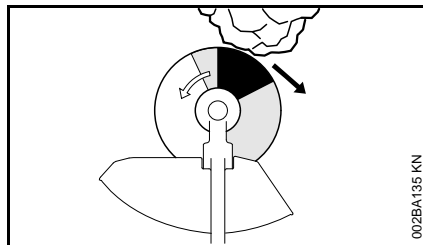

The **risk of kickout is greatest** when the **black area** of the rotating cutting attachment comes into contact with a solid object.

### Grass Cutting Blade

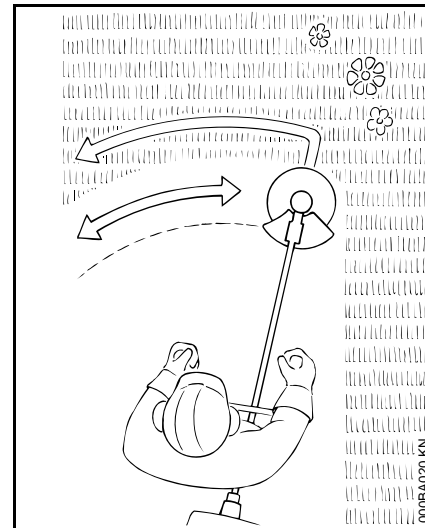

Use for grass and weeds only – sweep the brushcutter in an arc like a scythe.

### WARNING

Improper use may damage the grass cutting blade – **risk of injury** from thrown parts.

Resharpener the grass cutting blade according to instructions when it has dulled noticeably.

### Brush Knife

For cutting matted grass, wild growth and scrub and thinning young stands with a stem diameter of no more than 2 cm – do not cut thicker stems – **risk of accidents**.

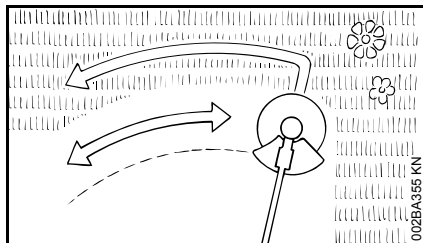

Use the brushcutter like a scythe (sweep it to the right and left) at ground level when cutting grass and thinning young stands.

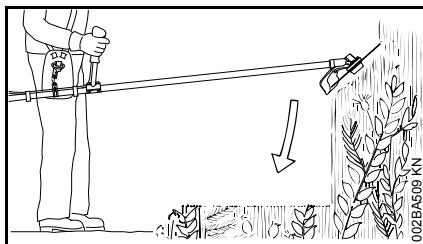

To cut wild growth and scrub, lower the brush knife down onto the growth to achieve a shredding effect – always keep the cutting attachment below hip level during this process.

Exercise extreme caution when using this method of cutting. The higher the cutting attachment is off the ground, the greater the risk of injury from cuttings being thrown sideways.

Warning! Improper use of a brush knife may cause it to crack, chip or shatter – **risk of injury** from thrown parts.

To reduce the risk of injury it is essential to take the following precautions:

- Avoid contact with stones, rocks, pieces of metal and other solid foreign objects.
- Never cut wood or shrubs with a stem diameter of more than 2 cm – use a circular saw blade for such work.
- Inspect the brush knife at regular short intervals for signs of damage. Do not continue working with a damaged brush knife.
- Resharpener the brush knife regularly and whenever it has dulled noticeably, and have it balanced if necessary (STIHL recommends a STIHL servicing dealer).

### Circular Saw Blade

Suitable for cutting shrubs and trees with a maximum stem diameter of 4 cm.

Before starting the cut, accelerate the engine up to full throttle. Perform cut with uniform pressure.

Use circular saw blades only with a matching limit stop of the correct diameter.

### **!** WARNING

To reduce the risk of blade damage, avoid contact with stones and the ground. Resharpener the blade properly in good time – dull teeth may result in the blade cracking and shattering and causing serious injury.

When felling, maintain a distance of at least two tree lengths from the next felling site.

### Risk of kickout

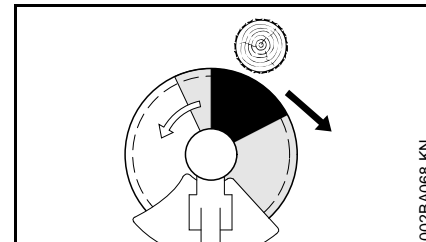

The risk of kickout is highest in the black area of the blade: Do not use this area of the circular saw blade for cutting.

There is also a risk of kickout when using the lighter shaded areas of the blade: These areas of the blade should only be used by experienced operators with specialized training.

STIHL recommends that you use the non-shaded area of the circular saw blade. Always start the cut with this area of the blade.

## Approved KombiEngines

### KombiMotors

Only use KombiEngines/Motors supplied or explicitly approved by STIHL for use with the attachment.

Depending on the cutting attachment used, always refer to and observe the chapter on "Approved Combinations of Cutting Attachment, Deflector, Handle and Harness".

This KombiTool may be operated only in combination with the following KombiEngines/Motors:

STIHL KM 55 R, KM 56 R, KM 85 R<sup>1)</sup>,  
KM 91 R, KM 94 R, KM 111 R,  
KM 131 R1), KM 130 R, KMA 130 R

### **WARNING**

Loop-handled machines must be equipped with a barrier bar.

### Brushcutters with split drive tube

This KombiTool may also be mounted to STIHL brushcutters (basic power tools) with a split drive tube (T models).

Operation of this KombiTool is therefore also permitted on the following power tool model:

STIHL FR 131 T







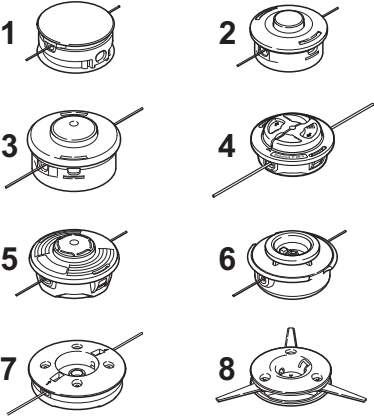
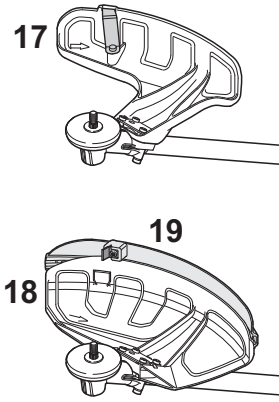

---

<sup>1)</sup> outside the EU only

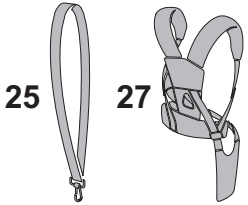
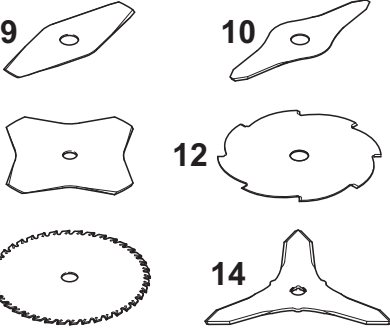
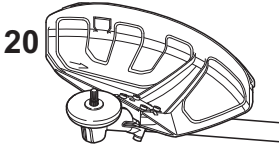
### **WARNING**

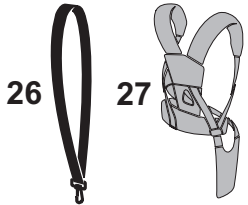
Refer to the power tool's instruction manual for use of the barrier bar.

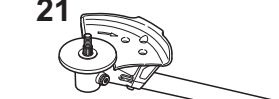
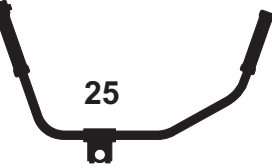
## Approved Combinations of Cutting Attachment, Deflector, Handle and Harness

Cutting Attachment		Deflector, Limit Stop	Handle	Harness
 <p>1, 2, 3, 4, 5, 6, 7, 8</p>	 <p>17, 18, 19</p>	 <p>22, 23</p>	 <p>25, 27</p>	
 <p>9, 10, 11, 12, 13, 14</p>	 <p>20</p>	 <p>22, 23</p>	 <p>26, 27</p>	
 <p>15, 16</p>	 <p>21</p>	 <p>24, 25</p>	 <p>28</p>	

0000-GXX-0371-A1

## Approved Combinations

Select correct combination from the table according to the cutting attachment you intend to use.

### **WARNING**

For safety reasons only the cutting attachments, deflectors, handles and harnesses shown in each row of the table may be used together. No other combinations are permitted because of the **risk of accidents**.

### **WARNING**

Loop-handled machines must be equipped with a barrier bar.

## Cutting Attachments

### Mowing heads

- 1 STIHL SuperCut 20-2
- 2 STIHL AutoCut C 25-2
- 3 STIHL AutoCut 25-2
- 4 STIHL AutoCut C 26-2
- 5 STIHL AutoCut 36-2
- 6 STIHL FixCut 31-2
- 7 STIHL TrimCut 31-2
- 8 STIHL DuroCut 20-2
- 9 STIHL PolyCut 20-3

### Metal cutting attachments

- 10 Grass cutting blade 230-2  
(230 mm dia.)
- 11 Grass cutting blade 260-2  
(260 mm dia.)

- 12 Grass cutting blade 230-4  
(230 mm dia.)
- 13 Grass cutting blade 230-8  
(230 mm dia.)
- 14 Grass cutting blade 250-40 Spezial  
(250 mm dia.)
- 15 Brush knife 250-3<sup>1)</sup>  
(250 mm dia.)
- 16 Scratcher tooth circular saw blade 200<sup>1)2)</sup>  
(200 mm dia.)
- 17 Chisel tooth circular saw blade 200<sup>1)2)</sup>  
(200 mm dia.)

### **WARNING**

Non-metal grass cutting blades, brush knives and circular saw blades are not approved.

## Deflectors, Limit Stop

- 18 Deflector for mowing heads
- 19 Deflector **with**
- 20 skirt and blade, for mowing heads
- 21 Deflector **without** skirt and blade, for metal cutting attachments 10 to 15

1) Not approved for KM 55, KM 55 R, KM 56, KM 56 R, FS 55 T, FS 55 RT

2) Not approved for FR 85 T and FR 130 T, KM 55 R, KM 56 R, KM 85 R, KM 90 R, KM 94 R, KM 100 R, KM 110 R, KM 130 R, KMA 130 R

- 22 Limit stop for circular saw blades

## Handles

- 23 Loop handle **with**
- 24 Barrier bar
- 25 Bike handle

## Harnesses

- 26 Shoulder strap may be used
- 27 Shoulder strap must be used
- 28 Full harness may be used
- 29 Full harness must be used

## Mounting the KombiTool

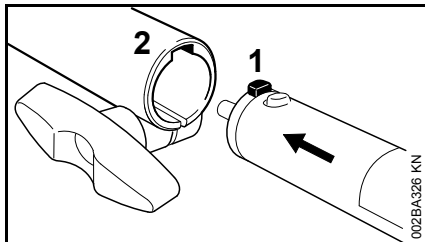

- Push the lug (1) on the drive tube into the slot (2) in the coupling sleeve as far as stop.

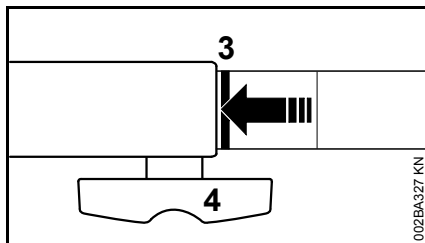

When correctly installed, the red line (3) (arrow point) must be flush with the end of the coupling sleeve.

- Tighten down the star knob (4) **firmly**.

### Removing the KombiTool

- Reverse the above sequence to remove the drive tube.

## Mounting the Deflector

### Mounting the Deflector

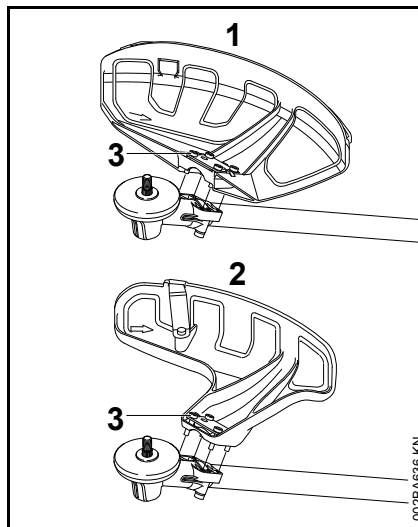

- 1 Deflector for mowing attachments
- 2 Deflector for mowing heads

Deflectors (1 and 2) are both mounted to the gearbox in the same way.

- Place the deflector on the gearbox flange.
- Insert the screws (3) and tighten them down firmly.

### Fitting the Skirt and Blade

#### **!** WARNING

Risk of injury from thrown objects and contact with the cutting attachment. These parts must be fitted to the deflector (1) when you use a mowing head.

### Fitting the Skirt

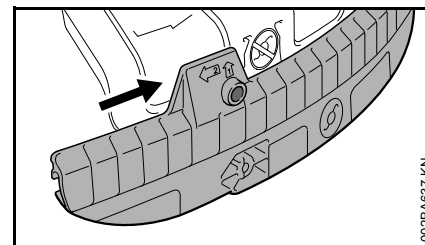

- Slide the lower guide slot of the skirt onto the deflector – it must snap into position.

### Removing the Skirt

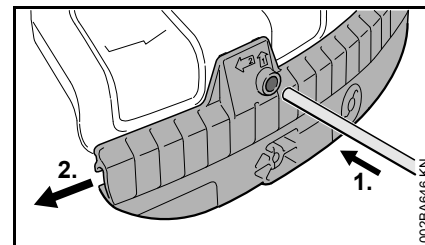

- Insert the stop pin into the hole in the skirt and use it to push the skirt to the left.
- Pull the skirt off the deflector.

## Mounting the Blade

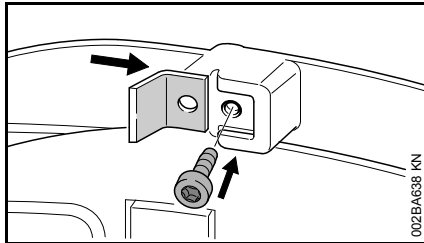

- Slide the line limiting blade into the guide on the skirt.
- Insert the screw and tighten it down firmly.

## Mounting the Limit Stop

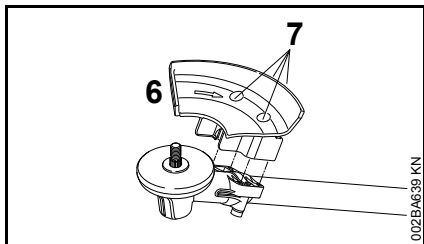

### **!** WARNING

Risk of injury from thrown objects and contact with the cutting attachment. Always fit the limit stop (6) when you use a circular saw blade.

- Position the limit stop (6) on the gearbox flange.
- Insert the screws (7) and tighten them down firmly.

## Mounting the Cutting Attachment

### Placing power tool on the ground

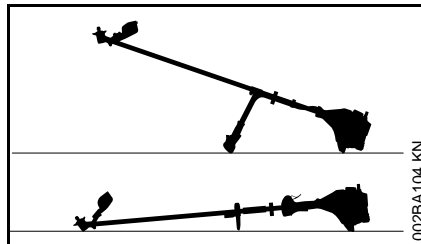

- Shut off the engine.
- Lay your power tool on its back so that the cutting attachment mounting face is pointing up.

### Mounting Hardware for Cutting Attachments

The mounting hardware supplied depends on the cutting attachment that comes as original equipment with the new machine.

### Machine supplied with mounting hardware

Mowing heads and metal cutting attachments may be mounted.

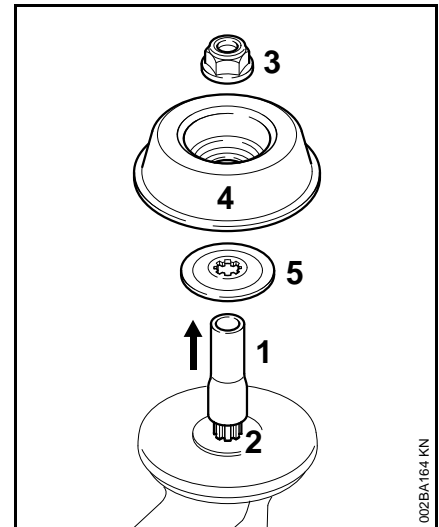

Depending on the cutting attachment, it may be necessary to use the nut (3), rider plate (4) and thrust washer (5).

These parts are included in a kit supplied with the machine and are also available as special accessories.

### Removing the transport lock

- Pull the hose (1) off the shaft (2).

### Machine supplied without mounting hardware

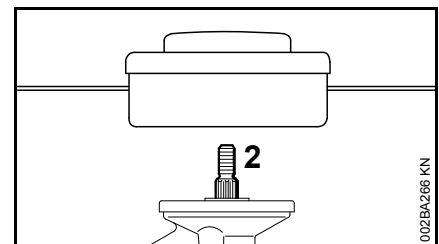

Only mowing heads may be used which mount directly to the shaft (2).



## Blocking the Shaft

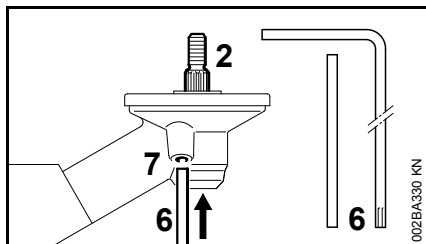

The output shaft (2) must be blocked with the stop pin (6) or screwdriver (6) to mount or remove cutting tools. These parts come standard with the machine or are available as special accessories.

- Insert the stop pin (6) or screwdriver (6) in the hole (7) in the gearbox as far as stop – and apply slight pressure.
- Rotate shaft, nut or cutting attachment until the stop pin slips into position and blocks the shaft.

## Removing the Mounting Hardware

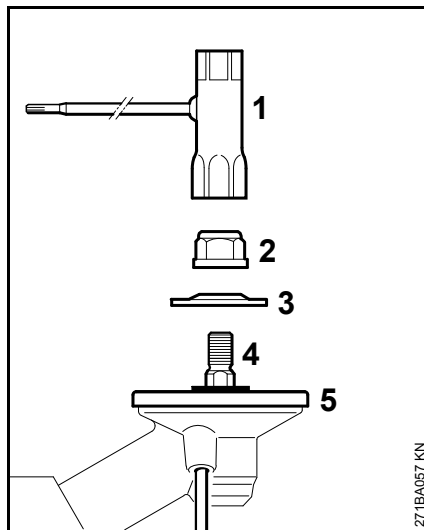

- Block the shaft.
- Use the combination wrench (1) to loosen and remove the nut (2) **clockwise** (left-hand thread).
- Take the thrust washer (3) off the shaft (4). **Do not** remove the thrust plate (5).

## Mounting the Cutting Attachment



### WARNING

Use a deflector that matches the cutting attachment – see "Mounting the Deflector".

## Fitting Mowing Head with Screw Mounting

Keep the instruction leaflet for the mowing head in a safe place.

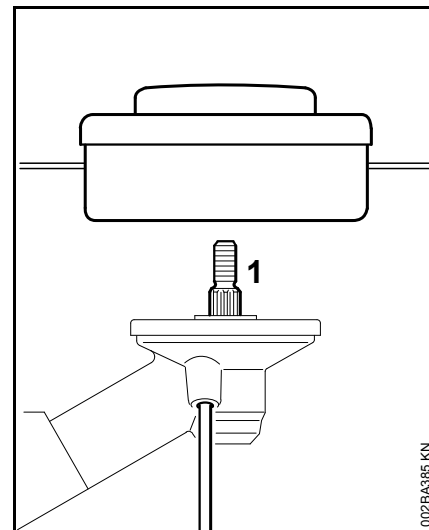

- Screw the mowing head counterclockwise on to the shaft (1) as far as stop.
- Block the shaft.
- Tighten down the mowing head firmly.



Remove the tool used to block the shaft.

## Removing the Mowing Head

- Block the shaft.
- Unscrew the mowing head clockwise.

## Fitting Mowing Head without Screw Mounting

Keep the instruction leaflet for the mowing head in a safe place.

### STIHL FixCut 31-2

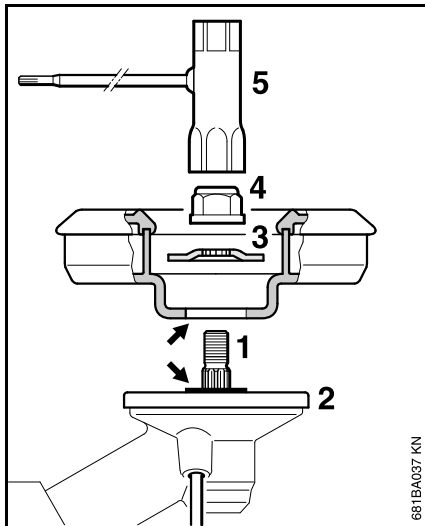

- Fit the thrust plate (2).
- Place the mowing head on the thrust plate (2).

#### **! WARNING**

Collar (see arrows) must engage the mowing head's mounting hole.

- Push the thrust washer (3) (convex side up) over the shaft (1) until it is seated on the base.
- Block the shaft.
- Use the combination wrench (5) to screw the mounting nut (4) onto the output shaft and it tighten down firmly.

#### **! WARNING**

If the mounting nut has become too loose, fit a new one.

#### **⚙ NOTICE**

Remove the tool used to block the shaft.

### Removing the Mowing Head

- Block the shaft.
- Use the combination wrench to loosen and unscrew the mounting nut counterclockwise from the output shaft.

### Mounting Metal Cutting Attachments

Keep the leaflet and packaging of the metal cutting attachment in a safe place.

#### **! WARNING**

Wear protective gloves to reduce the risk of direct contact with the sharp cutting edges.

Mount only one metal cutting attachment.

### Check direction of rotation of cutting attachment

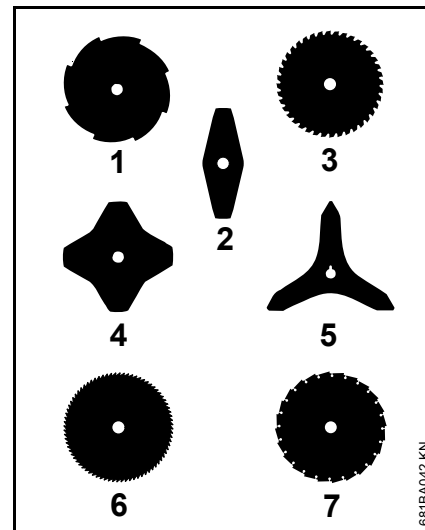

Cutting attachments 2, 4 and 5 may be mounted either way round – they must be turned over regularly to help avoid one-sided wear.

The cutting edges of cutting attachments 1, 3, 6 and 7 must point clockwise.

#### **! WARNING**

Direction of rotation is indicated by an arrow on the inside of the deflector.

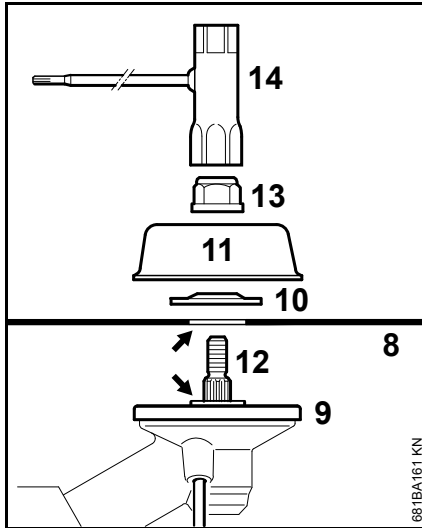

- Place the cutting attachment (8) on the thrust plate (9).

### **! WARNING**

Collar (see arrow) must engage the cutting attachment's mounting hole.

### Securing the cutting attachment

- Fit the thrust washer (10) – convex side must face up.
- Fit the rider plate (11).
- Block the shaft (12).
- Use the combination wrench (14) to screw the mounting nut (13) on to the output shaft counterclockwise and tighten it down firmly.

### **! WARNING**

If the mounting nut has become too loose, fit a new one.

### **! NOTICE**

Remove the tool used to block the shaft.

### Removing the Metal Cutting Attachment

### **! WARNING**

Wear protective gloves to reduce the risk of direct contact with the sharp cutting edges.

- Block the shaft.
- Unscrew the mounting nut clockwise.
- Remove cutting attachment and its mounting hardware from the gearbox – but **do not** remove the thrust plate (9).

## Fitting the Harness

The type and style of the harness, carrying ring and carabiner (spring hook) depend on the market.

The use of the harness is described in the chapter on "Approved Combinations of Cutting Attachment, Deflector, Handle and Harness".

### Shoulder strap

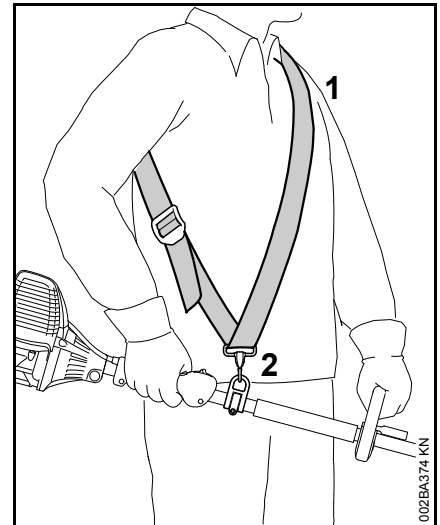

- Put on the shoulder strap (1).
- Adjust the length of the strap so that the carabiner (2) is about a hand's width below your right hip.
- Balance the machine – see "Balancing the Machine".

## Full Harness

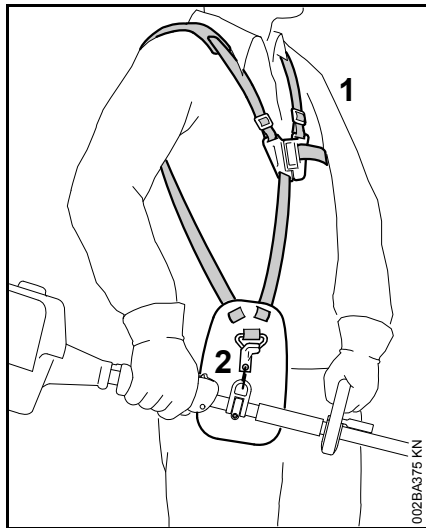

- Put on the full harness (1).
- Adjust the length of the strap so that the carabiner (2) is about a hand's width below your right hip.
- Balance the machine – see "Balancing the Machine".

## Attaching Machine to Harness

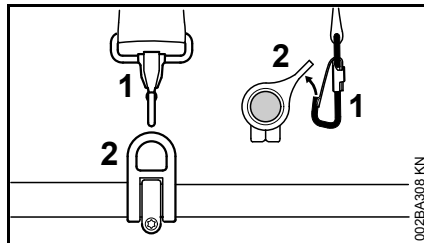

- Attach the carabiner (1) to the carrying ring (2) on the drive tube – hold the carrying ring steady.

## Disconnecting Machine from Harness

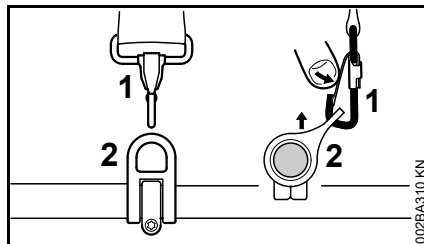

- Press down the bar on the carabiner (1) and pull the carrying ring (2) out of the carabiner.

## Throwing Off the Machine

### **WARNING**

The machine must be quickly thrown off in the event of imminent danger. Practice removing and putting down the machine as you would in an emergency. To avoid damage, do not throw the machine to the ground when practicing.

Practice quickly detaching the power tool from the carabiner as described under "Disconnecting Machine from Harness".

If you are using a shoulder strap: Practice slipping the strap off your shoulder.

If you are using a full harness: Practice quickly opening the locking plate and slipping the harness straps off your shoulders.

## Balancing the Machine

### Balancing the Machine

The unit is balanced differently depending on the cutting attachment used.

Proceed as follows until the conditions specified under "Floating positions" have been met:

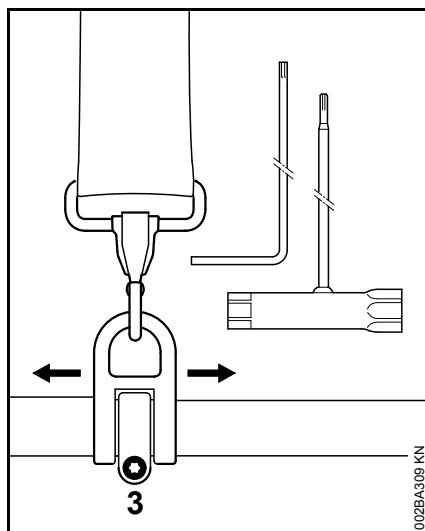

- Loosen the screw (3).
- Adjust the carrying ring.
- Tighten the screw moderately.
- Allow the unit to hang freely.
- Check the position obtained.

### Floating positions

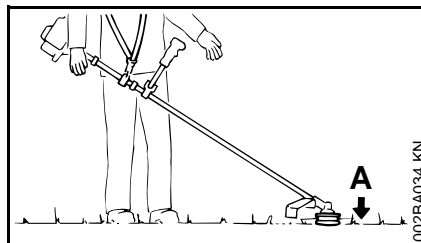

Mowing tools (A) such as mowing heads, grass cutting blades and brush knives

- should just touch the ground.

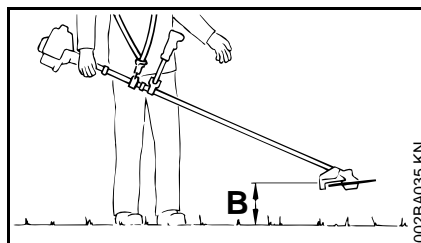

Circular saw blades (B)

- should "hover" about 20 cm (8 in) above the ground.

When the correct floating position has been reached:

- Tighten down the screw on the carrying ring firmly.

## Starting / Stopping the Engine

### Starting the Engine

Always follow the operating instructions for the KombiEngine and basic power tool.

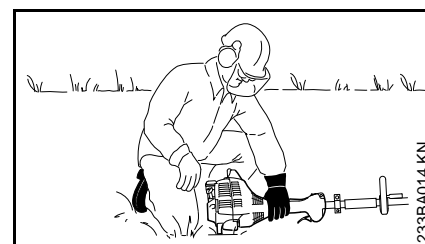
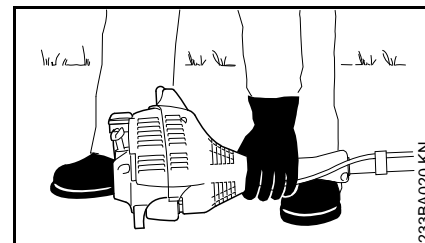

- Put the unit on the ground: It must rest securely on the engine support and the deflector.
- If fitted: Remove the transport guard from the cutting attachment.

**To reduce the risk of accidents,** check that the cutting attachment is not touching the ground of any other obstacles.

- Make sure you have a firm footing, either standing, stooping or kneeling.
- Hold the unit **firmly** on the ground with your left hand and press down – do not touch the throttle trigger or lockout lever – your thumb should be under the fan housing.

 **NOTICE**

Do not stand or kneel on the drive tube.

 **WARNING**

The cutting attachment may begin to move as soon as the engine starts. For this reason, blip the throttle after starting – the engine returns to idling speed.

The starting procedure is now as described in the instruction manual of the KombiEngine or basic power tool you are using.

Stopping the Engine

- See instruction manual of the KombiEngine or basic power tool.

**Transporting the Unit**

Using Transport Guard

The type of transport guard depends on the metal cutting attachment supplied with the machine. Transport guards are available as special accessories.

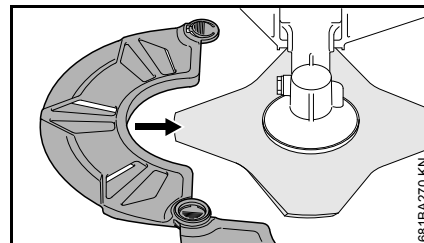

230 mm Grass Cutting Blades

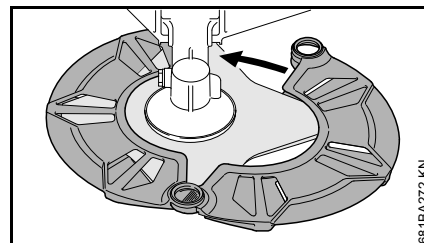
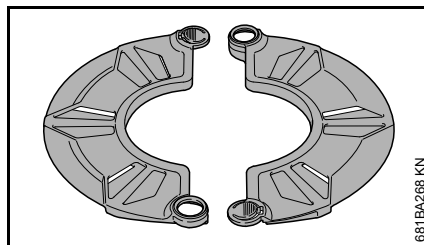

250 mm Brush Knives

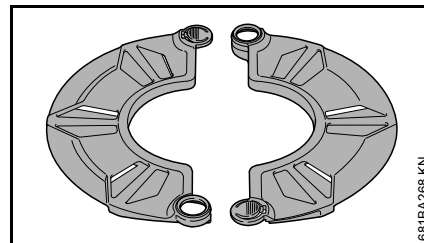
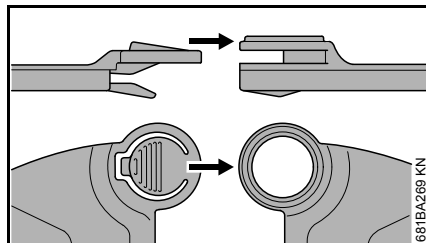

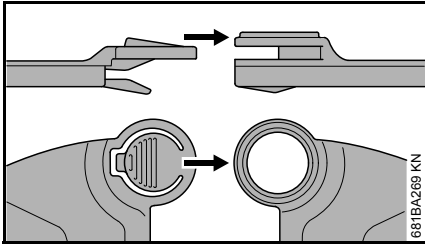

681BA269 KN

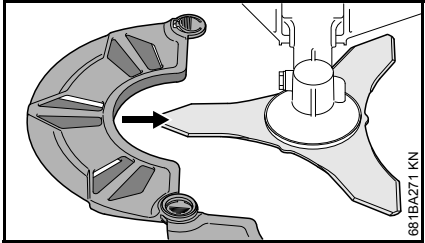

681BA271 KN

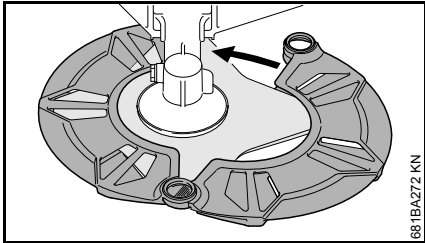

681BA272 KN

**Grass Cutting Blades up to 260 mm**

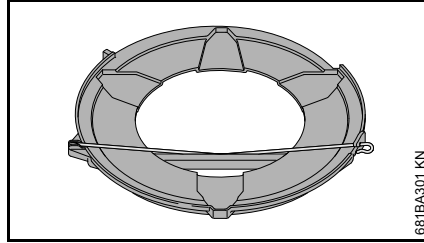

681BA301 KN

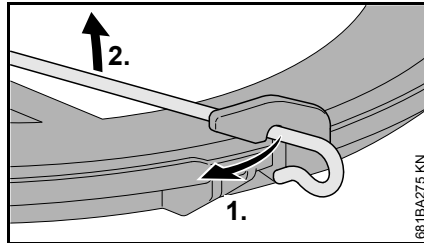

681BA275 KN

- Disconnect wire rod from the transport guard.
- Swing wire rod outwards.

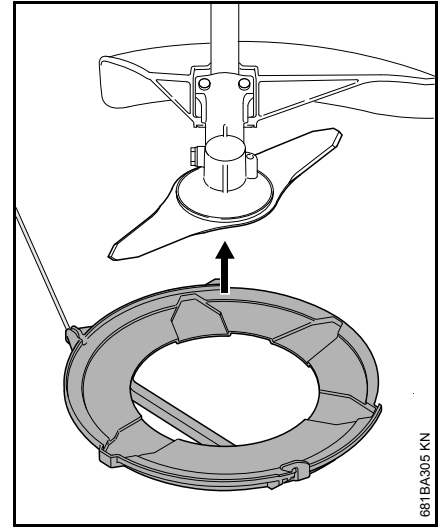

681BA305 KN

- Fit the transport guard on the cutting attachment from below.

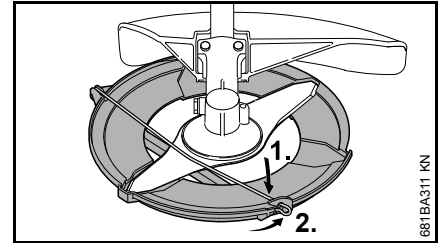

681BA311 KN

- Swing wire rod into position.
- Hook wire rod to the transport guard.

## Circular Saw Blades

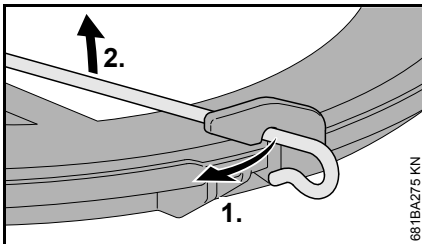
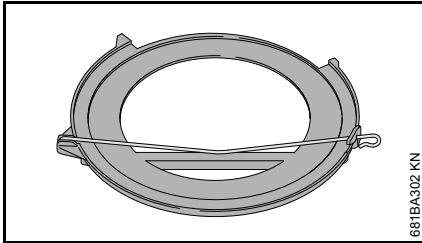

- Disconnect wire rod from the transport guard.

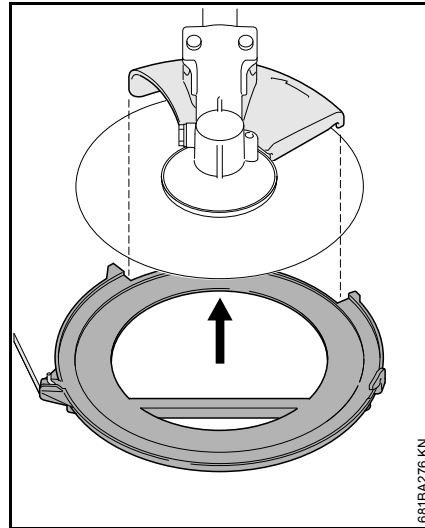

- Swing wire rod outwards.
- Fit transport guard on saw blade from below, making sure the limit stop is properly seated in the recess.

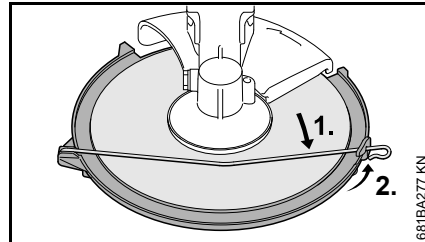

- Swing wire rod into position.
- Hook wire rod to the transport guard.

## Lubricating the Gearbox

### Gearbox without Screw Plug

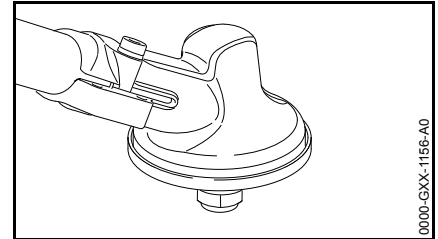

- If the gearbox has no screw plug: gearbox is maintenance-free and requires no re-lubrication.

### Gearbox with Screw Plug

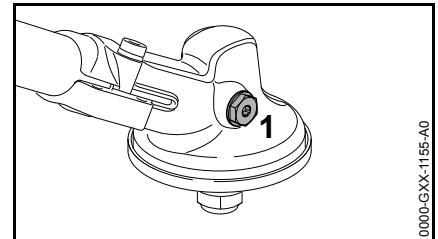

- If the gearbox has a screw plug (1): Check grease level after every 25 hours of operation and re-lubricate if necessary.



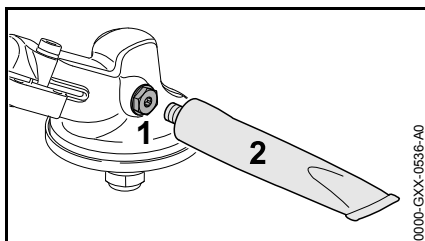

- Remove the screw plug (1).
- If no grease can be seen on the inside of the screw plug (1): Screw the tube (2) of STIHL gear lubricant (special accessory) into the filler hole.
- Squeeze no more than 5 g (1/5 oz) grease into the gearbox.

#### NOTICE

Do not completely fill the gearbox with grease.

- Unscrew the tube (2).
- Insert the screw plug (1) and tighten it down firmly.

## Storing the Machine

For periods of about 3 months or longer

- Remove, clean and inspect the cutting attachment. Coat metal cutting attachments with corrosion inhibitor.
- Thoroughly clean the machine.
- If the KombiTool is removed from the KombiEngine and stored separately: Fit the protective cap on the drive tube to avoid dirt getting into the coupling.
- Store the machine in a dry and secure location – out of the reach of children and other unauthorized persons.

## Sharpening Metal Cutting Blades

- Use a sharpening file (see "Special Accessories") to sharpen dull cutting attachments. In case of more serious wear or nicks: Resharpener with a grinder or have the work done by a dealer – STIHL recommends a STIHL servicing dealer.
- Sharpen frequently, take away as little metal as possible – two or three strokes of the file are usually enough.

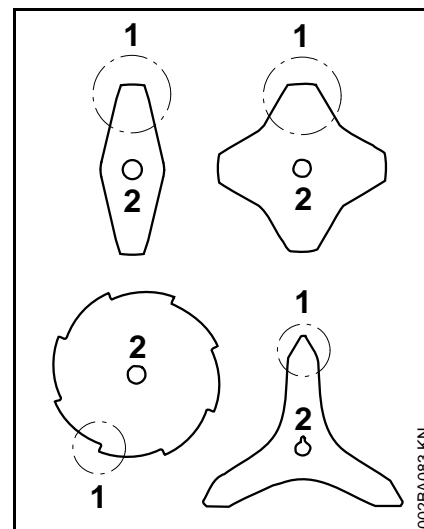

- Resharpener the teeth (1) uniformly – do not alter the contour of the parent blade (2) in any way.

See cutting attachment packaging for additional sharpening instructions. Keep the packaging for future reference.

## Balancing

---

- After resharpening about 5 times, check the cutting attachment for out-of-balance on a STIHL balancer – see “Special Accessories” – or have it checked by a dealer and re-balanced as necessary – STIHL recommends a STIHL servicing dealer.

## Maintaining the Mowing Head

### Placing power tool on the ground

---

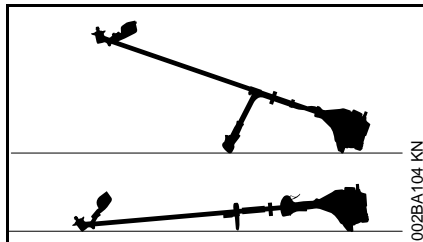

- Shut off the engine.
- Lay your power tool on its back so that the cutting attachment mounting face is pointing up.

### Replacing Nylon Line

---

Always check the mowing head for signs of wear before replacing the nylon line.

#### **WARNING**

If there are signs of serious wear, replace the complete mowing head.

The nylon mowing line is referred to as "nylon line" or "line" in the following.

The mowing head is supplied with illustrated instructions for replacing the nylon line. Keep the instructions for the mowing head in a safe place.

- If necessary, remove the mowing head.

## Adjusting Nylon Line

---

### STIHL SuperCut

Fresh line is advanced automatically if the remaining line is **at least 6 cm (2 1/2 in)** long. The blade on the deflector trims overlong lines to the correct length.

### STIHL AutoCut

- With the engine running, hold the rotating mowing head above the grass surface.
- Tap it on the ground once – fresh line is advanced and the blade on the deflector trims it to the right length.

Fresh line is advanced every time the mowing head is tapped on the ground. For this reason observe the mowing head's cutting performance during operation. If the mowing head is tapped on the ground too often, the line limiting blade will unnecessarily cut off unused lengths of nylon line.

Line feed operates only if both lines are still at least **2.5 cm (1 in)** long.

### Replacing Nylon Line

---

### STIHL PolyCut

Precut lengths of nylon line can be fitted to the PolyCut in place of the cutting blades.

## STIHL DuroCut, STIHL FixCut 31-2, STIHL PolyCut

### WARNING

To reduce the risk of injury, always shut off the engine before refilling the mowing head.

- Fit nylon line in the mowing head as described in the instructions supplied.

### Replacing Cutting Blades

#### STIHL PolyCut

Always check the mowing head for signs of wear before installing new cutting blades.

### WARNING

If there are signs of serious wear, replace the complete mowing head.

The thermoplastic cutting blades are referred to as "blades" in the following.

The mowing head is supplied with illustrated instructions for replacing the blades. Keep the instructions for the mowing head in a safe place.

### WARNING

To reduce the risk of injury, always shut off the engine before installing the blades.

- Remove the mowing head.
- Replace blades as shown in the illustrated instructions.
- Mount the mowing head on the machine.

## Maintenance and Care

The following intervals apply to normal operating conditions only. If your daily working time is longer or operating conditions are difficult, shorten the specified intervals accordingly.

### All accessible screws and nuts

- Retighten if necessary

### Cutting attachments

- Inspect for damage, check tightness before starting work and after every refueling stop
- Replace if damaged
- Sharpen metal cutting attachments before starting work if necessary

### Gearbox lubrication (only gearbox versions with screw plug)

- Check weekly
- Replenish as necessary

### Safety labels

- Replace illegible safety labels

## Main Parts

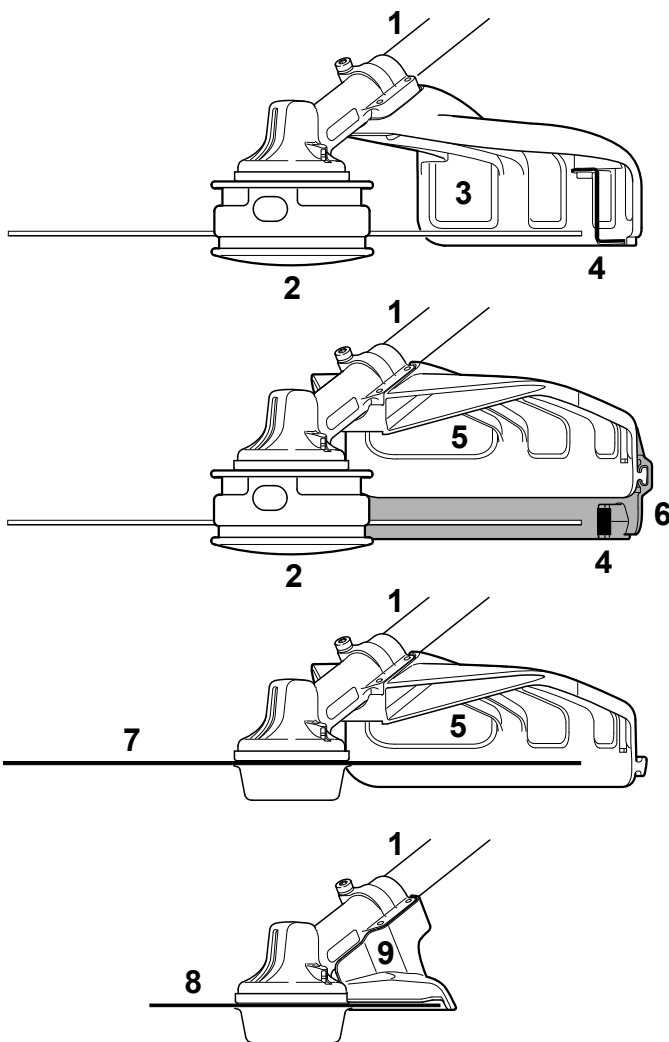

- 1 Drive tube
- 2 Mowing head
- 3 Deflector for mowing heads only
- 4 Line limiting blade
- 5 Deflector for all mowing attachments
- 6 Skirt for mowing heads
- 7 Metal mowing attachment
- 8 Circular saw blade
- 9 Limit stop for circular saw blades only

002BA644 KN

## Specifications

### Engine Speed

Max. output shaft speed at cutting attachment with KombiEngine/Motor:

KM 55 R:	7,500 rpm
KM 56 R:	7,600 rpm
KM 85 R:	7,900 rpm
KM 91 R:	7,150 rpm
KM 94 R:	7,300 rpm
KM 111 R:	7,150 rpm
KM 131, KM 131 R:	7150 rpm
KMA 130 R:	6,070 rpm

Max. output shaft speed at cutting attachment on STIHL brushcutters with split drive tube (T models):

FR 131 T:	7,150 rpm
-----------	-----------

### Weight

without cutting attachment and deflector 1.2 kg

### Noise and Vibration Data

Noise and vibration data measurements on power tools with the FS-KM KombiTool include idling and rated maximum speed with the same duration of exposure.

For further details on compliance with Vibration Directive 2002/44/EC visit [www.stihl.com/vib](http://www.stihl.com/vib).

### Sound pressure level $L_p$ to ISO 7917

with mowing head

KM 85 R with loop handle: 95 dB(A)

with metal mowing attachment

KM 85 R with loop handle: 94 dB(A)

### Sound pressure level $L_p$ to ISO 22868

with mowing head

KM 55 R with loop handle: 94 dB(A)

KM 56 R with loop handle: 94 dB(A)

KM 94 R with loop handle: 93 dB(A)

KM 111 R with loop handle: 96 dB(A)

KM 131 with bike handle: 98 dB(A)

KM 131 R with loop handle: 98 dB(A)

FR 131 T: 97 dB(A)

with metal mowing attachment

KM 55 R with loop handle: 93 dB(A)

KM 56 R with loop handle: 94 dB(A)

KM 94 R with loop handle: 92 dB(A)

KM 111 R with loop handle: 96 dB(A)

KM 131 with bike handle: 97 dB(A)

KM 131 R with loop handle: 97 dB(A)

FR 131 T: 97 dB(A)

### Sound pressure level $L_p$ to ISO 50636-2-91

with mowing head

KMA 130 R with loop handle: 83 dB(A)

with metal mowing attachment

KMA 130 R with loop handle: 79 dB(A)

### Sound power level $L_w$ to ISO 10884

with mowing head

KM 85 R with loop handle: 110 dB(A)

with metal mowing attachment

KM 85 R with loop handle: 109 dB(A)

### Sound power level $L_w$ to ISO 22868

with mowing head

KM 55 R with loop handle: 107 dB(A)

KM 56 R with loop handle: 106 dB(A)

KM 94 R with loop handle: 107 dB(A)

KM 111 R with loop handle: 108 dB(A)

KM 131 with bike handle: 109 dB(A)

KM 131 R with loop handle: 109 dB(A)

FR 131 T: 110 dB(A)

with metal mowing attachment

KM 55 R with loop handle: 106 dB(A)

KM 56 R with loop handle: 106 dB(A)

KM 94 R with loop handle: 107 dB(A)

KM 111 R with loop handle: 108 dB(A)

KM 131 with bike handle: 109 dB(A)

KM 131 R with loop handle: 109 dB(A)

FR 131 T: 109 dB(A)

**Sound power level  $L_w$  to EN 50636-2-91**

with mowing head KMA 130 R with loop handle:	93 dB(A)
with metal mowing attachment KMA 130 R with loop handle:	88 dB(A)

**Vibration level  $a_{hv,eq}$  to ISO 7916**

with mowing head KM 85 R with loop handle:	Handle, left 4.6 m/s <sup>2</sup>	Handle, right 6.0 m/s <sup>2</sup>
with metal mowing attachment KM 85 R with loop handle:	Handle, left 5.2 m/s <sup>2</sup>	Handle, right 6.2 m/s <sup>2</sup>

**Vibration level  $a_{hv,eq}$  to ISO 22867**

with mowing head KM 55 R with loop handle:	Handle, left 7.5 m/s <sup>2</sup>	Handle, right 8.0 m/s <sup>2</sup>
KM 56 R with loop handle:	6.3 m/s <sup>2</sup>	6.0 m/s <sup>2</sup>
KM 94 R with loop handle:	5.4 m/s <sup>2</sup>	6.3 m/s <sup>2</sup>
KM 111 R with loop handle:	4.5 m/s <sup>2</sup>	4.6 m/s <sup>2</sup>
KM 131 with bike handle:	4.9 m/s <sup>2</sup>	3.9 m/s <sup>2</sup>
KM 131 R with loop handle:	5.4 m/s <sup>2</sup>	4.9 m/s <sup>2</sup>
FR 131 T:	4.7 m/s <sup>2</sup>	4.3 m/s <sup>2</sup>

with metal mowing attachment KM 55 R with loop handle:	Handle, left 6.3 m/s <sup>2</sup>	Handle, right 8.0 m/s <sup>2</sup>
KM 56 R with loop handle:	5.5 m/s <sup>2</sup>	6.0 m/s <sup>2</sup>
KM 94 R with loop handle:	4.7 m/s <sup>2</sup>	5.4 m/s <sup>2</sup>
KM 111 R with loop handle:	4.2 m/s <sup>2</sup>	3.7 m/s <sup>2</sup>
KM 131 with bike handle:	5.0 m/s <sup>2</sup>	4.2 m/s <sup>2</sup>
KM 131 R with loop handle:	4.0 m/s <sup>2</sup>	4.3 m/s <sup>2</sup>
FR 131 T:	3.9 m/s <sup>2</sup>	2.9 m/s <sup>2</sup>

**Vibration level  $a_{hv,eq}$  to ISO 50636-2-91**

with mowing head KMA 130 R with loop handle:	Handle, left 4.4 m/s <sup>2</sup>	Handle, right 4.3 m/s <sup>2</sup>
with metal mowing attachment KMA 130 R with loop handle:	Handle, left 4.4 m/s <sup>2</sup>	Handle, right 3.7 m/s <sup>2</sup>

The K-factor in accordance with Directive 2006/42/EC is 2.0 dB(A) for the sound pressure level and sound power level; the K-factor in accordance with Directive 2006/42/EC is 2.0 m/s<sup>2</sup> for the vibration level.

**REACH**

REACH is an EC regulation and stands for the Registration, Evaluation, Authorisation and Restriction of Chemical substances.

For information on compliance with the REACH regulation (EC) No. 1907/2006 see [www.stihl.com/reach](http://www.stihl.com/reach).

## Maintenance and Repairs

Users of this machine may only carry out the maintenance and service work described in this user manual. All other repairs must be carried out by a servicing dealer.

STIHL recommends that you have servicing and repair work carried out exclusively by an authorized STIHL servicing dealer. STIHL dealers are regularly given the opportunity to attend training courses and are supplied with the necessary technical information.

When repairing the machine, only use replacement parts which have been approved by STIHL for this power tool or are technically identical. Only use high-quality replacement parts in order to avoid the risk of accidents and damage to the machine.

STIHL recommends the use of original STIHL replacement parts.

Original STIHL parts can be identified by the STIHL part number, the **STIHL** logo and the STIHL parts symbol  (the symbol may appear alone on small parts).

## Disposal

Observe all country-specific waste disposal rules and regulations.

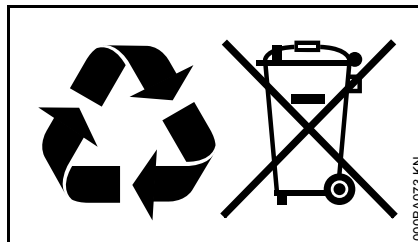

STIHL products must not be thrown in the garbage can. Take the product, accessories and packaging to an approved disposal site for environment-friendly recycling.

Contact your STIHL servicing dealer for the latest information on waste disposal.

## EC Declaration of Conformity

ANDREAS STIHL AG & Co. KG  
Badstr. 115  
D-71336 Waiblingen

Germany

declare in exclusive responsibility that

Category: Brushcutter  
KombiTool

Make: STIHL

Model: FS-KM

Serial identification: 4180

conforms to the relevant provisions of Directives 2006/42/EC and 2000/14/EC and has been developed and manufactured in compliance with the following standards in the versions valid on the date of production:

EN ISO 12100, EN ISO 11806-1 (in conjunction with the specified KM models).

EN ISO 12100, EN 60335-1, EN 50636-2-91 (in conjunction with the specified KMA models).

EN ISO 12100, EN ISO 11806-2 (in conjunction with the specified FR models).

The measured and guaranteed sound power levels were determined according to Directive 2000/14/EC, Annex V, using the ISO 10884 standard.

### Measured sound power level

with KM 55 R:	107 dB(A)
with KM 56 R:	106 dB(A)
with KM 85 R:	111 dB(A)
with KM 94 R:	106 dB(A)

*English*

with KM 111 R: 108 dB(A)  
with KM 131 / 131 R: 109 dB(A)  
with KMA 130 R: 93 dB(A)  
with FR 131 T: 110 dB(A)

**Guaranteed sound power level**

with KM 55 R: 109 dB(A)  
with KM 56 R: 108 dB(A)  
with KM 85 R: 112 dB(A)  
with KM 94 R: 108 dB(A)  
with KM 111 R: 110 dB(A)  
with KM 131 / 131 R: 111 dB(A)  
with KMA 130 R: 95 dB(A)  
with FR 131 T: 112 dB(A)

Technical documents deposited at:

ANDREAS STIHL AG & Co. KG  
Produktzulassung (Product Licensing)

The year of manufacture is applied to  
the power tool.

Done at Waiblingen, 07.03.2018

ANDREAS STIHL AG & Co. KG



Thomas Elsner

Director Product Management and  
Services











0458-407-8321-B

AUS



[www.stihl.com](http://www.stihl.com)



0458-407-8321-B