

## PG98230

20A/16A 30-Outlet 3-Phase Outlet-Metered & Switched eco PDU





# Optimize Data Center Sustainability



Up to 64 Cascaded 3-Phase PDUs with Space, Energy, and Connectivity Efficiency



When maintaining operating uptime in a [data center](#) or server room, sustainable energy efficiency can make all the difference. The implementation of effective power management often involves improvements at both the hardware and software level. As the trend for 3-phase power grows due to its efficiency to generate, transfer, and distribute electricity, ATEN is introducing its latest PG series of PDUs, available in IEC socket configuration, that are designed with 0U rack housing to accommodate the increasing demand for power to high-density IT equipment in server rooms and [data centers](#). Each PG98230 PDU, utilizing an ARM-Cortex A8 processor, is equipped with 30 port outlets capable of running at higher voltages, powers up all connected equipment in less than 10 seconds once plugged in, and delivers the most accurate kWh energy usage data (+/-1%) for better power consumption habits, baselines, and initiative tracking. With energy saving in mind, the PG98230 is purposed to enable lower energy consumption for best practice in a network infrastructure, while promoting up to 70.65 kg (131.4 kw equivalent of power consumption) of reduced CO2 emission, reduced electricity expenses, and lower carbon taxes to pay each year.

<p>kWh Metering Precision</p>	<p>3-Phase Power</p>	<p>ARM Cortex-A8 Processor</p>	<p>Network Redundancy</p>	<p>Power Monitoring</p>	<p>Environmental Monitoring</p>	<p>Console Panel Color Coding</p>
-------------------------------	----------------------	--------------------------------	---------------------------	-------------------------	---------------------------------	-----------------------------------

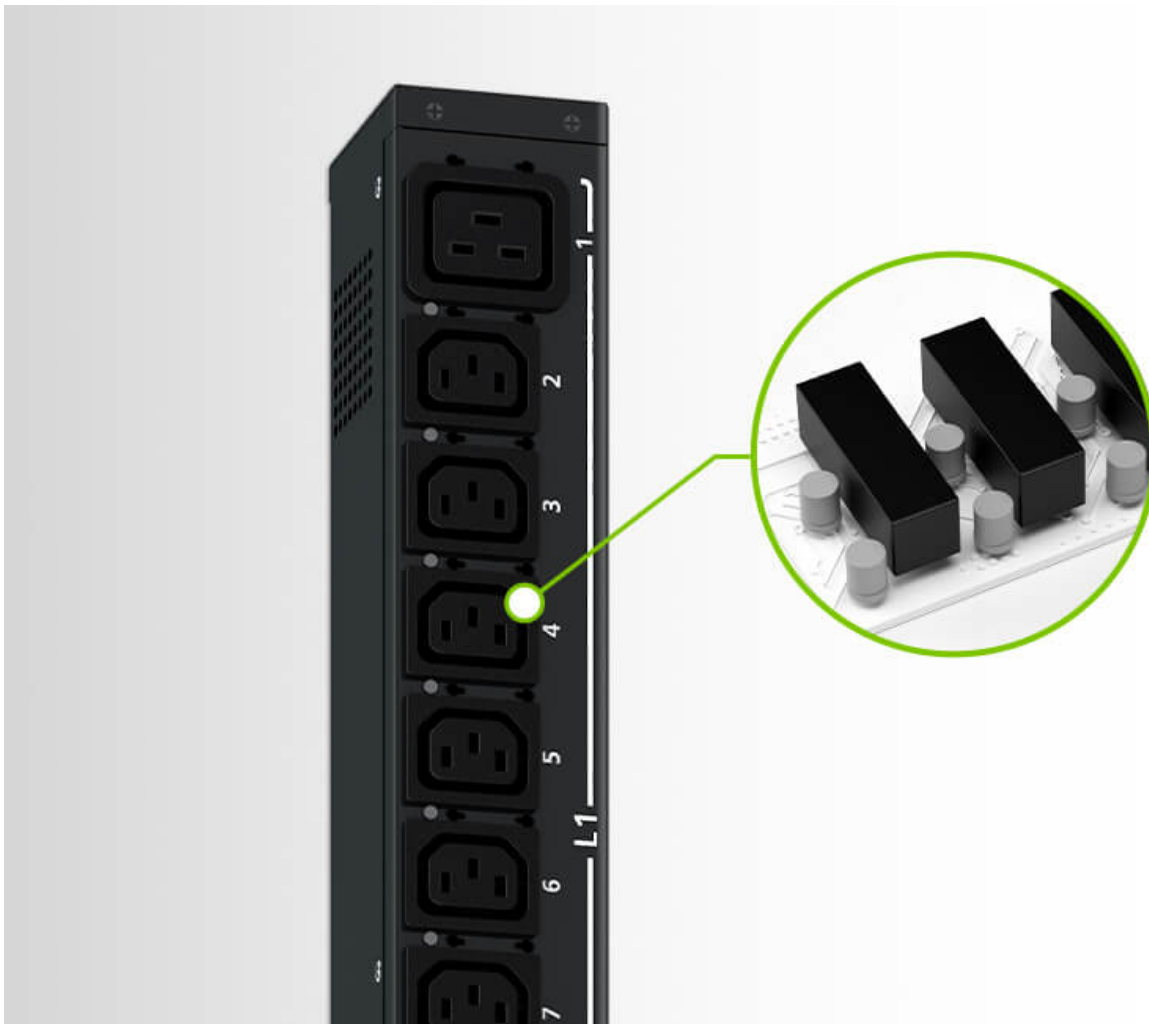

**Energy-Saving Relay**

Thanks to the built-in energy-saving relays - a subtype of electromagnetic switch - controlling a large amount of current flow becomes easy, which results in annual saving of 131.4 kW power consumption per 30-outlet PDU unit, compared with models without energy-saving relays. In addition, power distribution will remain functional and uninterrupted even when a failure occurs, enabling superior uptime to optimize system reliability.



**Secure Locking Enhancement**

The outlets can be protected with a secure lock to prevent power cords from becoming unplugged due to vibration or human errors.

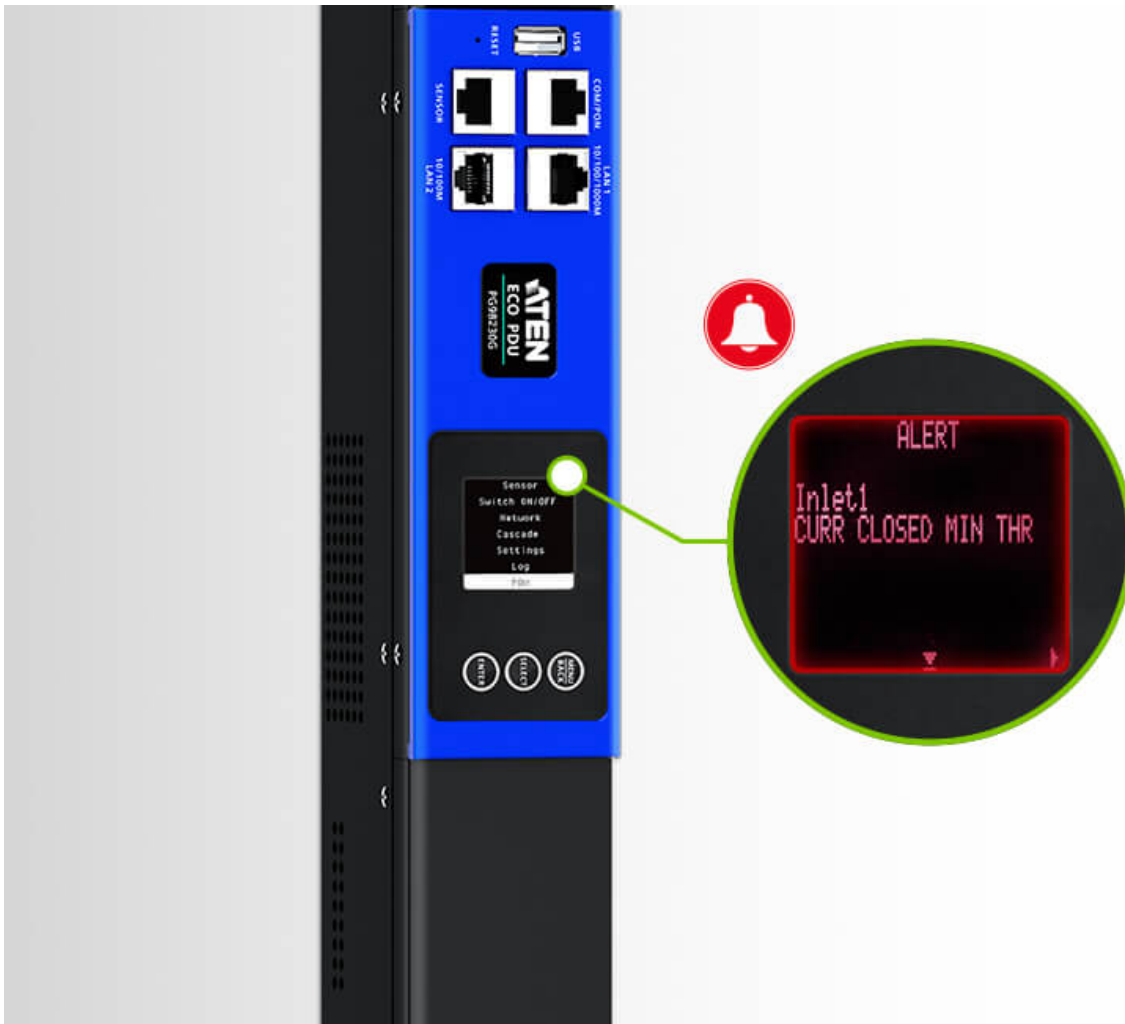

**Real-time Alerts via LCD Display**

The illuminated LCD display can display warnings to alert users of unusual power states.

**Hot-Swappable Function**

The LCD console panel is hot-swappable and can be removed, replaced, or repaired without powering down a mission-critical connected load.

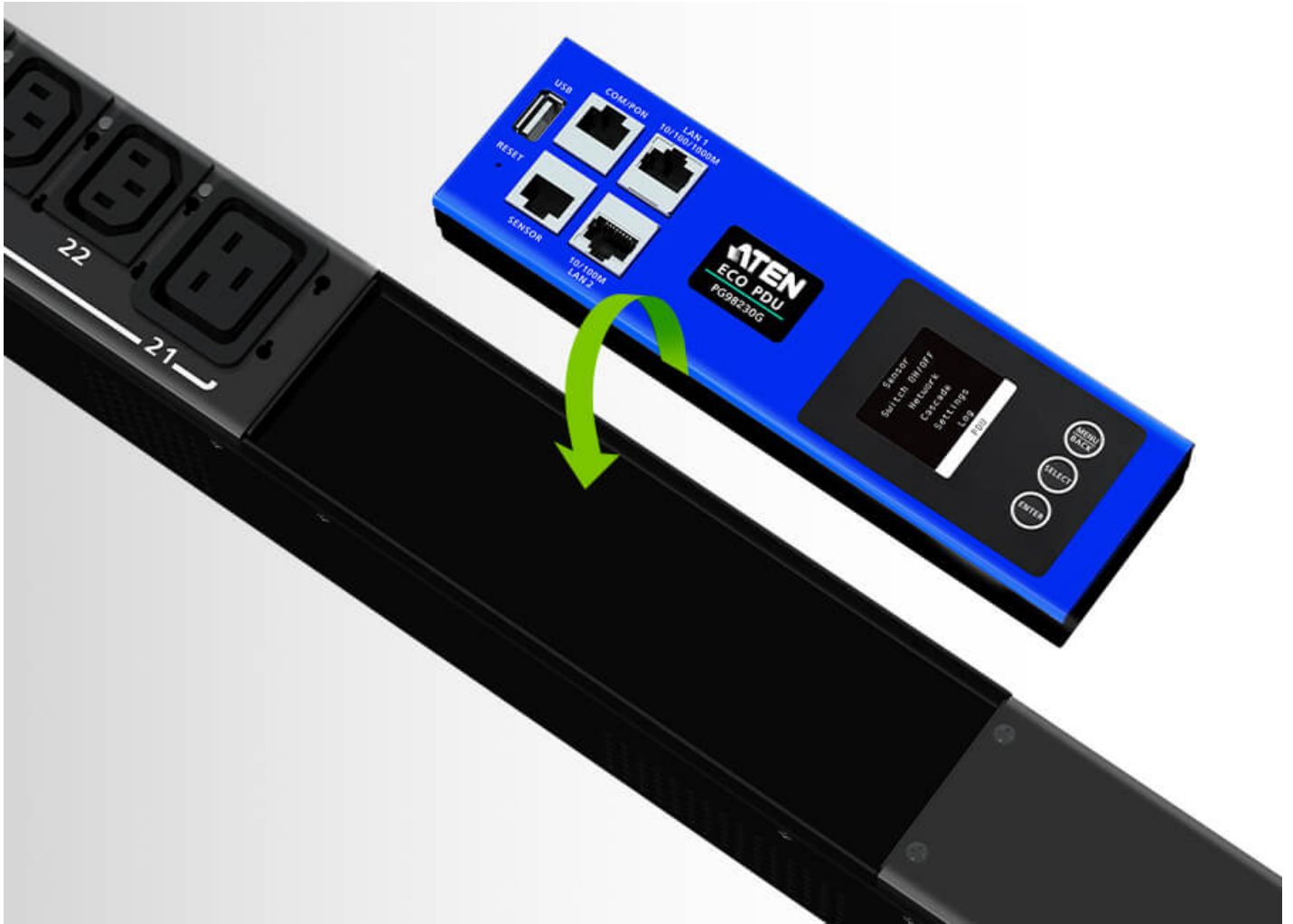



#### Dual LAN Ports for Scalable Network Setup

The PG98230 is equipped with dual LAN ports (e.g. Internet and Intranet) supporting up to 1G Ethernet connection, and can be cascaded to connect up to 64 PDUs, saving expense on installing extra network switches to incorporate network connections while sparing more rack space to accommodate more IT equipment in an expandable network.

#### Environment Sensors

The Sensor port enables RJ-45 connectivity to connect or daisy-chain up to 8 environment sensors for monitoring and management of temperature, humidity, airflow, differential air pressure, and leaks, featuring alerts for potential threats.







### Flexible On-Site Network Operation

For quick operation, connecting a serial device to the PDU with its COM port provides another means to undertake communication via CLI commands. In addition, the same port is also functional as a PON port, available for Ethernet connection to a KN series KVM over IP Switch to centralize power management of up to 16 daisy-chained PDUs.

## Contact Us

Get a quote for this product or get in touch with our sales experts

[Get Quote](#)

[Contact Sales](#)

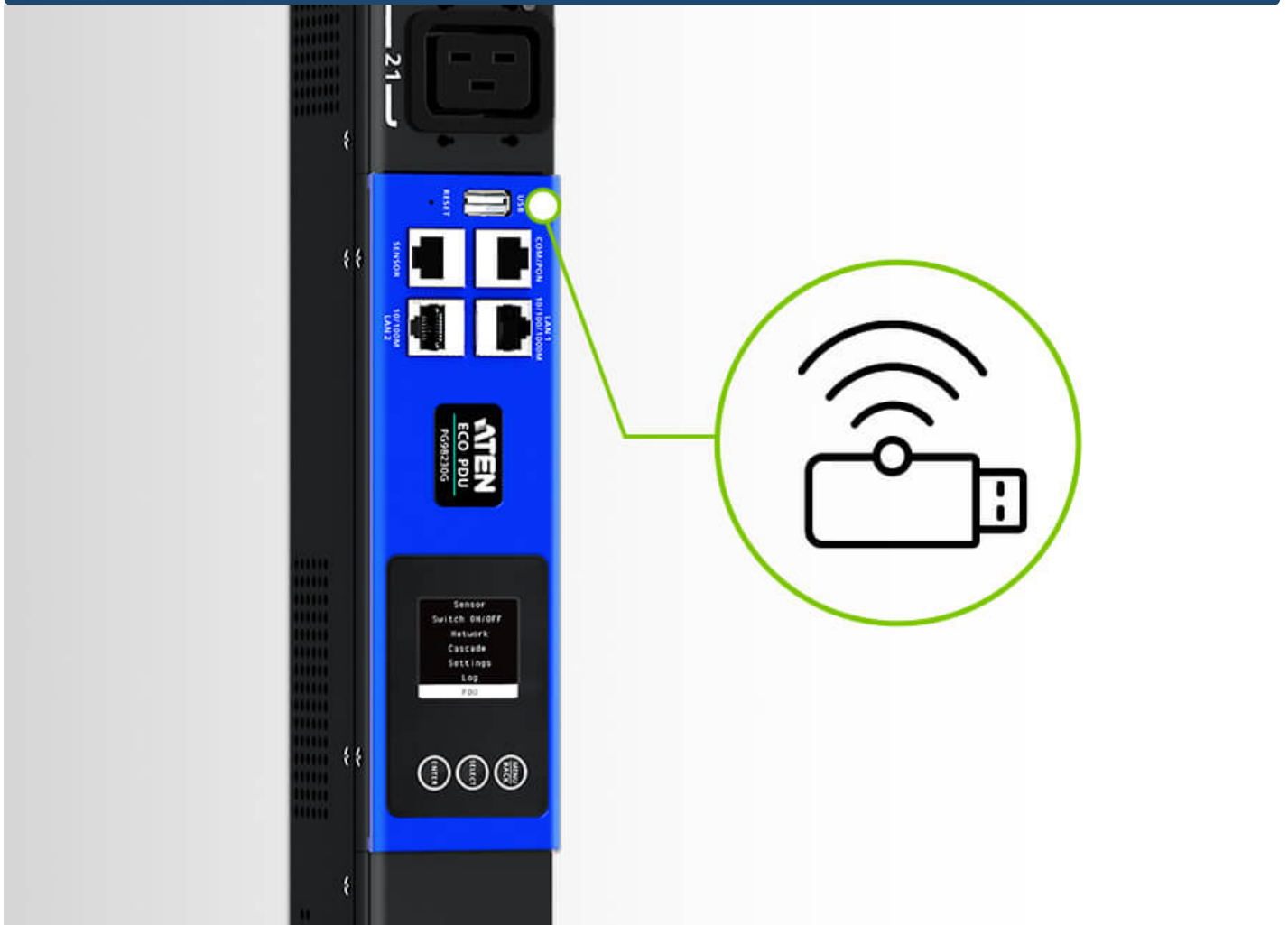

**Networkable via WiFi**

The PG98230 can be networked via connection to a USB WiFi dongle to perform DCIM, firmware upgrade, log export, quick configuration, and more.

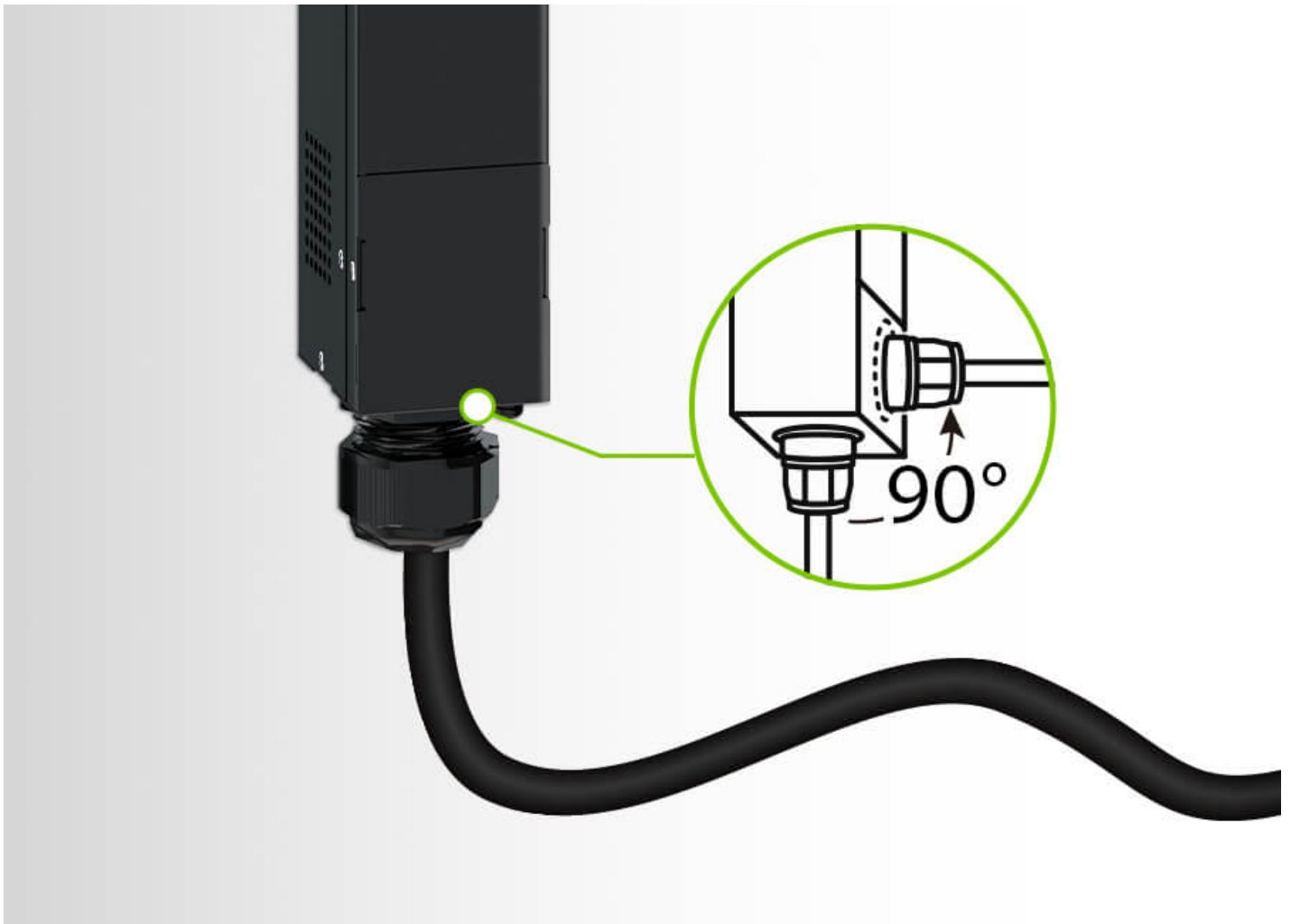

**Adjustable Power Cord for Flexible In-Rack Installation**

The PG98230 comes with an adjustable power cord built in to the unit capable of 90-degree rotation to allow flexible in-rack installation, resulting in better cable organization.

**DCIM Monitoring**

Integrated with ATEN's [eco DC](#) - a PC- and web-based tool for optimized [Data Center](#) Infrastructure Management (DCIM) - power distribution, energy, and environmental data from PDUs and connected devices can be monitored via a friendly web GUI for smart power management.

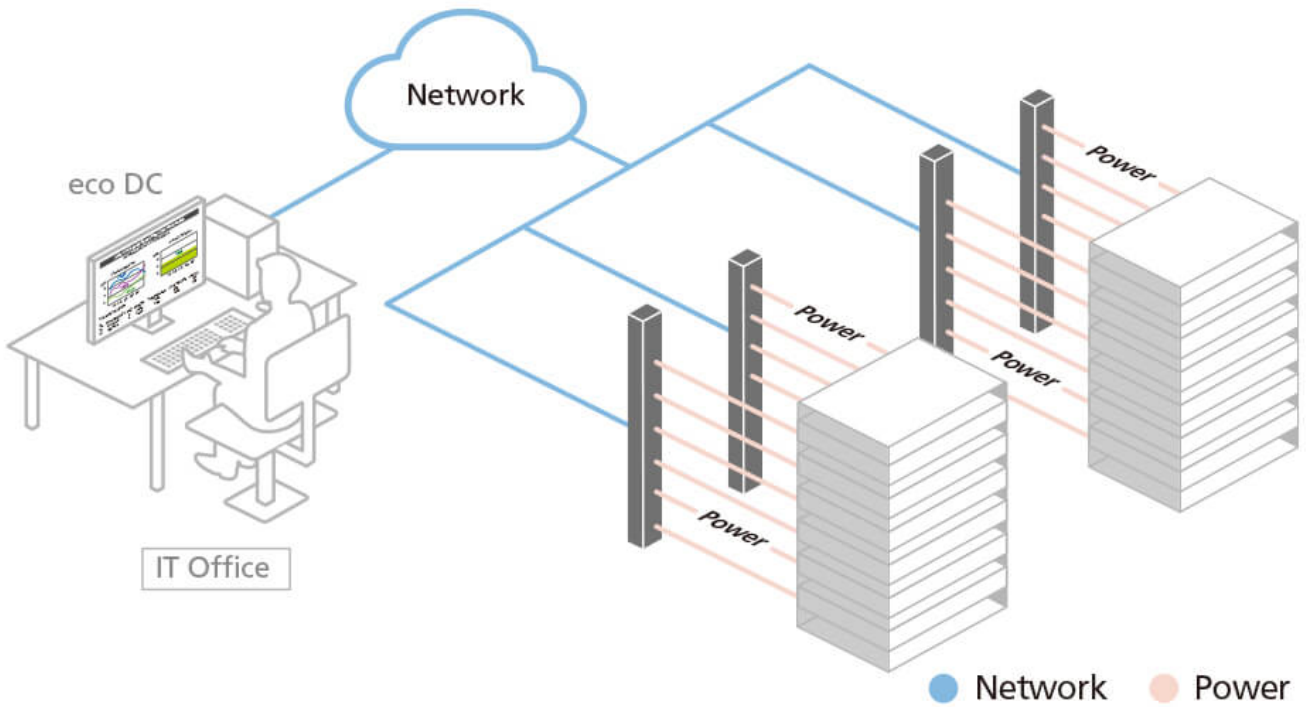

**Colored Panel for Smarter Power Monitoring**

The PG series PDUs feature a LCD console panel in default red and can be re-colored with options of yellow, purple, blue, and green through optional purchase of colored stickers. These color codes make it easier to differentiate between power feed settings and also speed up troubleshooting in case of unexpected failures.



### Applications

The PG series 3-Phase PDUs are perfectly suited to server rack installation requiring energy-efficient power distribution to high-density IT equipment in a server room or [data center](#).



Server Room  
Data Center

## Talk to Our Experts

If you prefer to have ATEN contact you, please complete the form and a representative will be in touch with you shortly

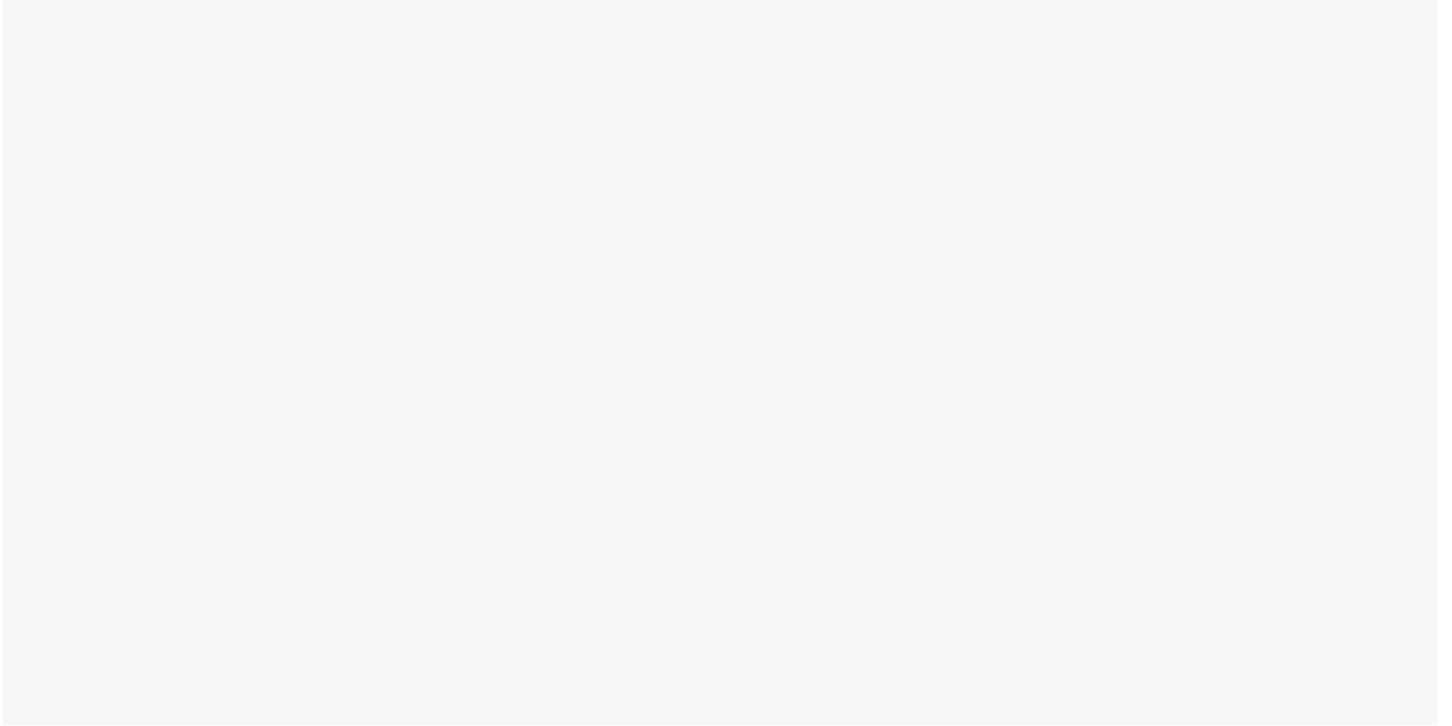

## Features

ATEN PG98 metered-switched-by-outlet 3-Phase PDU series ships with 6 x IEC 60320 C19 and 24 x IEC 60320 C13 outlets along with a 0U rack enclosure. Containing an ARM Cortex-A8 processor, the PG98 series delivers flexible control methods through its LAN / COM / USB / environmental sensor ports, while being able to power up all connected equipment in less than 10 seconds once plugged in. For cost-saving and space-efficient setup purposes, PG98 series can be cascaded to connect up to 64 PDU units. As a result, these PDUs accommodate the increasing demand for power to high-density IT devices in server rooms and [data centers](#).

In terms of hardware design, these PDUs have built-in energy-saving relays, a subtype of electromagnetic switch, to help operators control large amounts of current flow, which results in lower energy consumption compared to relay models incapable of energy saving.

With five colors (yellow, red, purple, blue, and green) of LCD console panel stickers available for users to choose from, differentiating between power feed settings and speeding up troubleshooting are made easier. Plus, the LCD console panel is hot-swappable and can be removed, replaced, or repaired without powering down a mission-critical connected load.

Ideal for enterprise servers, network closets, and [data centers](#), the PG98 series is an intelligent power distribution and management solution that supports high-density IT applications while minimizing the overall cost.

- ARM Cortex-A8 processor for flexible control methods via LAN / COM / USB / environmental sensor ports and enhanced monitoring via LCD console
- **Advantageous hardware / network specifications**
  - 1 Gbps Ethernet Interface
  - Auto Ping & Reboot
  - [Remote Management](#) Protocols: TCP/IP, UDP, HTTP, HTTPS, SSL, DHCP, SMTP, ARP, NTP, DNS, Auto Sense, Ping, SNMP V1&V2&V3, Telnet, Modbus (over TCP/IP), Wi-Fi, 802.11 a/b/g/n network protocols, IPv6, and SMS
  - Alerts / Alarms: receives alarms via SNMP, SMTP, SMS<sup>1</sup>, and syslog
  - Scripting: JSON-RPC (Remote Procedure Call) protocol and Python scripting to control specified PDU unit (e.g. Switch On / Off)<sup>1</sup>
  - Security: 2-level account / password login access, and IP / MAC filter, TLS 1.2, SMTP / SMTPS protocols
  - Authentication: LDAP, RADIUS, TACACS+
- **Expandable installation**
  - Allows for connecting up to 64 PDU units with cascading
  - Up to 16 PDU units can be daisy chained via LAN port connection and PON port connection to ATEN's KN series KVM over IP Switches<sup>2</sup>
- Energy-efficient relays allow operators to control large amounts of current flow for lower energy consumption
- Precise kWh metering (+/-1% ) for better power consumption habits, baselines, and initiative tracking
- Environmental sensor port enables RJ-45 connectivity to connect or daisy-chain up to 8 environmental sensors for monitoring and management of temperature, humidity, airflow, differential air pressure, and leaks<sup>3</sup>
- Real-time LCD Alert sends warnings to alert users of unusual power state
- An adjustable power cord is built in to the unit cable of 90-degree rotation to allow flexible in-rack installation, resulting in better cable organization
- Secure locking enhancement prevents power cords from becoming unplugged due to vibration or human error
- Supports ATEN's [eco DC](#) (Energy & DCIM Management Web GUI) for monitoring power distribution, energy, and environmental data from PDUs and connected devices

### Note:

1. To be included in a future firmware release.
2. Firmware upgrade of the KN series is required.
3. Please contact the local sales representative for further information on the environmental sensor.



**Specifications**

Function	PG98230B	PG98230B2	PG98230G
<b>Electrical</b>			
Nominal Input Voltage	208V 3PH (Delta)	208V 3PH (Delta)	400/230V 3PH (Star)
Maximum Input Current	20A Max 16A(UL de-rated)	20A Max 16A(UL de-rated)	16A Max
Input Frequency	50-60 Hz	50-60 Hz	50-60 Hz
Input Connection	NEMA L21-20P	NEMA L15-20P	IEC 309 16/20A Red 3P+N+PE
Input Power	7205VA(Max), 5764VA(UL de-rated)	7205VA(Max), 5764VA(UL de-rated)	11084VA(Max)
Outlet Type	(6) IEC 320 C19, (24) IEC 320 C13	(6) IEC 320 C19, (24) IEC 320 C13	(6) IEC 320 C19, (24) IEC 320 C13
Nominal Output Voltage	208 VAC	208 VAC	230 VAC
Maximum Output Current (Outlet)	C13: 15A(Max),12A(UL de-rated) C19: 20A(Max),16A (UL de-rated)	C13: 15A(Max),12A(UL de-rated) C19: 20A(Max),16A (UL de-rated)	C13:10A(Max), C19:16A(Max),
Breakers	NA	NA	NA
Metering	Outlet level Current, Voltage , PF and KWh Monitoring	Outlet level Current, Voltage , PF and KWh Monitoring	Outlet level Current, Voltage , PF and KWh Monitoring
Outlet Switching	Yes	Yes	Yes
Environment Sensor Ports	Yes	Yes	Yes
Metering Accuracy	1%	1%	1%
<b>Physical Properties</b>			
Dimensions (L x W x H)	179.00 x 5.60 x 6.80 cm (70.47 x 2.2 x 2.68 in.)	179.00 x 5.60 x 6.80 cm (70.47 x 2.2 x 2.68 in.)	179.00 x 5.60 x 6.80 cm (70.47 x 2.2 x 2.68 in.)
Weight	7.36 kg ( 16.21 lb )	7.36 kg ( 16.21 lb )	7.36 kg ( 16.21 lb )
Power Cord Length	3m	3m	3m
<b>Environmental</b>			
Temperature (Operating / Storage)	0 - 60°C / -20 - 60°C	0 - 60°C / -20 - 60°C	0 - 60°C / -20 - 60°C
Humidity (Operating & Storage)	0 - 80% RH, Non-Condensing	0 - 80% RH, Non-Condensing	0 - 80% RH, Non-Condensing
<b>Compliance</b>			
EMC Verification	FCC	FCC	CE, EMC
Safety Verification	UL, PSE	UL, PSE	CE
Warranty	3 years	3 years	3 years
Note	For some of rack mount products, please note that the standard physical dimensions of WxDxH are expressed using a LxWxH format.		

Diagram

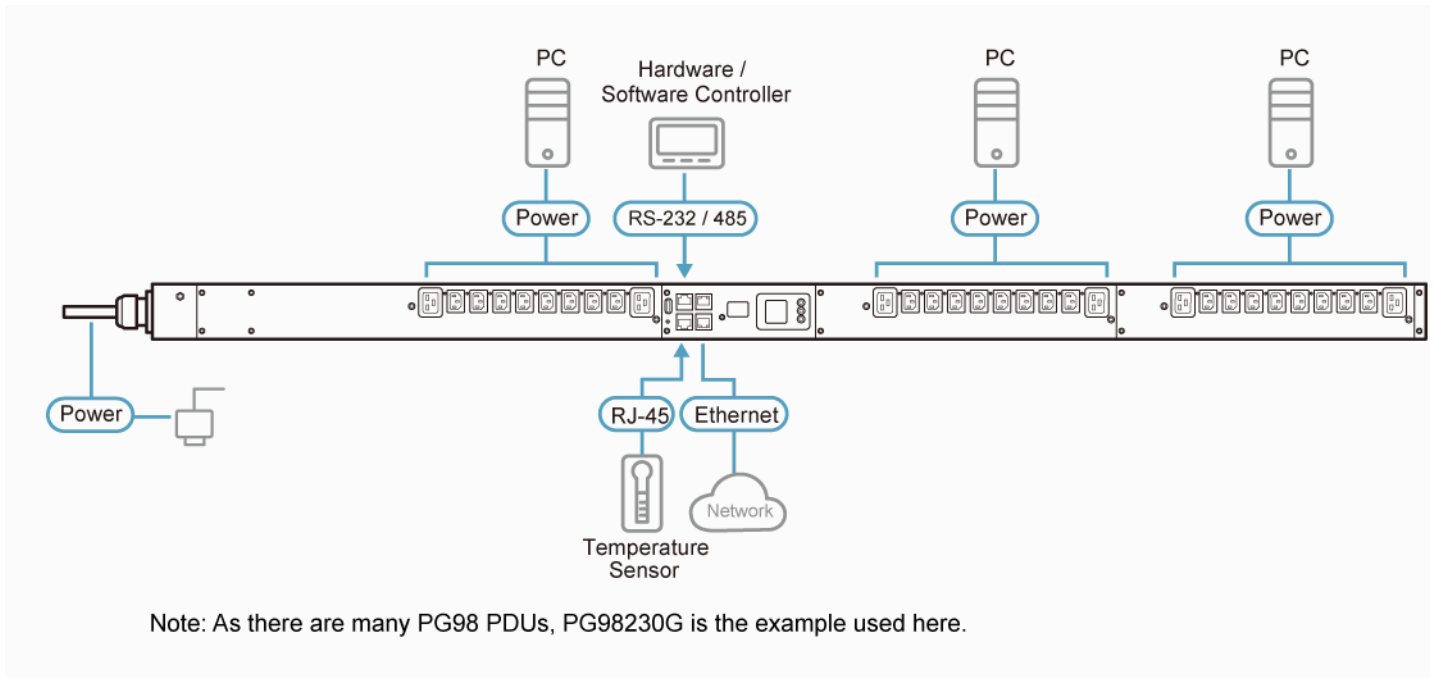

Note: As there are many PG98 PDUs, PG98230G is the example used here.

**ATEN International Co., Ltd.**

3F., No.125, Sec. 2, Datong Rd., Sijhih District., New Taipei City 221, Taiwan  
Phone: 886-2-8692-6789 Fax: 886-2-8692-6767  
www.aten.com E-mail: marketing@aten.com



© Copyright 2015 ATEN® International Co., Ltd.  
ATEN and the ATEN logo are trademarks of ATEN International Co., Ltd.  
All rights reserved. All other trademarks are the property of their respective owners.