

peerless-AV[®]

MOD-FCSKIT300 MOD-FCSKIT300-B

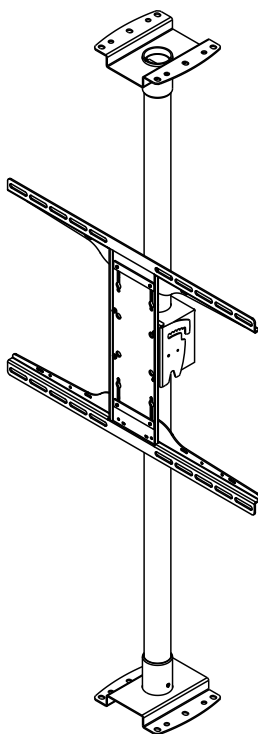

ENG	Compatible model/series*	MOD-ACF
ESP	Modelo/serie compatible*	
FRN	Modèle/gamme compatible*	
DEU	Kompatible Modelle/Serien*	
NEL	Compatibel model/serie*	
ITL	Modello/serie* compatibile	
ČES	Kompatibilní Model/série*	
SLK	Kompatibilný Model/séria*	
POR	Modelos/séries compatíveis	
TÜR	Uyumlu modeller/ seriler*	

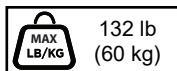
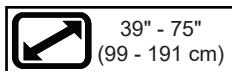

▲ WARNING

ENG - This product is designed to be installed on wood joist/beam or solid concrete ceilings. Hardware is included for wood joist/beam and solid concrete installation. Before installing make sure the supporting surface will support the combined load of the equipment and hardware. Screws must be tightly secured. Do not overtighten screws or damage can occur and product may fail. Never exceed the Maximum Load Capacity. Always use an assistant or mechanical lifting equipment to safely lift and position equipment. This product is intended for indoor use only. Use of this product outdoors could lead to product failure or personal injury. Be careful not to pinch fingers when operating the mount. For support please call customer care at 1-800-865-2112.

▲ ADVERTENCIA

ESP - Este producto está diseñado para ser instalado en techos de viguetas / vigas de madera y en techos de concreto macizo. Se incluyen los accesorios para la instalación en viguetas / vigas de madera y concreto macizo. Antes de instalarlo, asegúrese de que la superficie de apoyo sostendrá la carga combinada del equipo y los fijadores. Los tornillos se tienen que fijar firmemente. No apriete los tornillos en exceso, ya que se pueden dañar y el producto podría fallar. Nunca exceda la Capacidad Máxima de Carga. Siempre cuente con la ayuda de un asistente o utilice un equipo mecánico de izar para levantar y colocar el equipo con más seguridad. Este producto está diseñado para uso en interiores solamente. Utilizar este producto en exteriores podría causar fallas del producto o lesiones a individuos. Tenga cuidado de no pincharse los dedos cuando mueva el soporte. Si necesita ayuda, por favor, llame a Servicio al Cliente de Peerless al 1-800-865-2112.

▲ ADVERTISSEMENT

FRN - Ce produit est conçu pour une installation sur des plafonds à solives/montants en bois ou en béton plein. Les pièces de fixation nécessaires à l'installation sur des solives/montants en bois et du béton plein sont incluses. Avant de procéder à l'installation, assurez-vous que la surface de support peut soutenir la charge totale de l'équipement ainsi que des pièces de fixation. Les vis doivent être serrées au maximum. Ne serrez pas trop les vis pour éviter tout risque d'endommager le produit et de causer sa défaillance. Ne dépassez jamais la capacité de charge maximale. Pour lever et positionner l'équipement en toute sécurité, faites-vous toujours aider par une autre personne ou utilisez un dispositif de levage mécanique. Ce produit est conçu uniquement pour un usage intérieur. L'utilisation de ce produit à l'extérieur peut causer une défaillance du produit ou des blessures corporelles. Prenez garde à ne pas vous pincer les doigts lorsque vous manipulez le support. Pour toute assistance, veuillez contacter le service à la clientèle au 1-800-865-2112.

▲ ACHTUNG

DEU - Dieses Produkt ist für die Anbringung an Holzträger-/Holzbalken- oder Massivbetondecken ausgelegt. Die Befestigungsteile zur Anbringung an Holzträgern/-balken oder Massivbeton sind im Lieferumfang enthalten. Vergewissern Sie sich vor der Anbringung, dass die tragende Fläche das Gesamtgewicht der Geräte und der Befestigungsteile tragen kann. Die Schrauben müssen sicher angezogen werden. Ziehen Sie die Schrauben nicht zu fest an, damit es nicht zu Beschädigungen und Versagen des Produkts kommt. Die maximale Tragfähigkeit darf niemals überschritten werden. Ziehen Sie immer eine zusätzliche Person heran oder verwenden Sie mechanische Hebegeräte, um Geräte sicher zu heben und zu positionieren. Dieses Produkt ist nur für den Gebrauch innerhalb von Gebäuden bestimmt. Eine Verwendung dieses Produkts im Freien kann zu Produktausfall oder Personenschaden führen. Achten Sie beim Umgang mit dem Halter darauf, dass die Finger nicht eingeklemmt werden. Falls Sie Unterstützung benötigen, wenden Sie sich bitte an den Kundendienst unter der Telefonnummer 1-800-865-2112 (innerhalb der USA).

▲ WAARSCHUWING

NEL - Dit product is ontworpen voor installatie op plafonds met houten balken/dwarsbalken of plafonds van massief beton. De hiervoor benodigde hardware is meegeleverd. Vóór de installatie dient u zich ervan te overtuigen dat het dragende oppervlak het totaalgewicht van de apparatuur en de hardware aankan. Alle schroeven moeten stevig vastzitten. Draai de schroeven niet te strak aan, want dit zou kunnen resulteren in schade en/of falen van het product. Het maximale draagvermogen mag nooit worden overschreden. Belangrijke veiligheidstip: zorg er tijdens het optillen en plaatsen van de apparatuur altijd voor dat u een helper of een mechanische hefinrichting ter beschikking hebt. Dit product is uitsluitend bedoeld voor gebruik binnenshuis. Als dit product buitenshuis wordt gebruikt, zijn falen van het product en letsel bij personen mogelijk. Let er tijdens het gebruiken van de bevestiging op dat uw vingers niet beklemd raken. Voor ondersteuning kunt u terecht bij de afdeling Klantenzorg op +1-800-865-2112 (in de VS).

▲ AVVERTENZA

ITL - Questo prodotto è indicato per l'installazione su soffitti in calcestruzzo solido o a travi/traverse di legno. Sono compresi i dispositivi di fissaggio per l'installazione su calcestruzzo solido e a travi/traverse di legno. Prima di iniziare l'installazione, accertarsi che la superficie di supporto sia in grado di sorreggere il carico combinato unità/dispositivi di fissaggio. Le viti devono essere strette in maniera ben salda. Non serrare le viti oltre il necessario, altrimenti si rischiano danni o guasti al prodotto. Non superare mai la capacità massima di carico. Per sollevare e posizionare senza rischi il prodotto, farsi aiutare da un'altra persona o usare un'unità meccanica di sollevamento. Questo prodotto è indicato esclusivamente per uso all'interno. L'uso di questo prodotto all'esterno potrebbe causare il malfunzionamento del prodotto o danni fisici alla persona. Fare attenzione a non schiacciarsi le dita durante l'uso del sostegno. Per assistenza, chiamare il servizio clienti al numero 1-800-865-2112.

▲ VÝSTRAHA

ČEŠ - Tento produkt je určen pro instalaci na stropy z dřevěné stropnice/trámy nebo masivního betonu. Přibalené je technické vybavení pro instalaci na dřevěné stropnice/trámy a masivní beton. Před instalací se ujistěte, že nosná plocha unese kombinované zatížení zařízení a technického vybavení. Šrouby musí být pevně zajištěny. Šrouby přilíši neutahujte, nebo může dojít k poškození a produkt se může poškodit. Nikdy nepřekročte maximální nosnost. Na bezpečné zvedání a umísťování zařízení vždy používejte asistenta nebo mechanické zvedací zařízení. Tento produkt je určen pouze pro použití v interiéru. Použití tohoto produktu v exteriéru by mohlo způsobit selhání produktu nebo zranění osob. Při práci s držákem dávejte pozor, abyste si nesevěřili prsty. Pro podporu volejte oddělení péče o zákazníky na čísle 1-800-865-2112.

▲ VÝSTRAHA

SLK - Tento produkt je určený na inštaláciu na stropy z drevených nosníkov/trámov alebo masívneho betónu. Príbalené je technické vybavenie pre inštaláciu na stropy z drevených nosníkov/trámov alebo masívneho betónu. Pred montážou overte, či nosný povrch unesie kombinované zaťaženie zariadenia a vybavenia. Skrutky je potrebné pevne utiahnuť. Skrutky nedoťahujte príliš silno, inak môže dôjsť k poškodeniu a poruche zariadenia. Nikdy neprekračujte maximálnu nosnosť. Na bezpečné zdvíhanie a umiestňovanie zariadení vždy použite pomocníka alebo mechanické zdvíhacie zariadenie. Tento produkt je určený len na použitie v interiéri. Pri použití tohto produktu v exteriéri by mohlo dôjsť k jeho poruche alebo osobnému poraneniu. Pri práci s držiakom dávajte pozor, aby ste si nezovreli prsty. Podporu získate v centre na podporu zákazníkov na čísle 1-800-865-2112.

▲ AVISO

POR - Este produto foi concebido para ser instalado em traves/vigas de madeiras ou em tetos de betão. São incluídas ferragens para a instalação em traves/vigas de madeira e tetos de betão. Antes de instalar, certifique-se de que a superfície de apoio suporta a carga combinado do equipamento e das ferragens. Os parafusos devem ser bem apertados. Não aperte demasiado os parafusos, pois podem ocorrer danos ou falhas do produto. Nunca exceder a Capacidade de carga máxima. Utilize sempre um assistente ou equipamento de elevação mecânica para elevar e posicionar o equipamento em segurança. Este produto destina-se a utilização exclusivamente em zonas interiores. A utilização deste produto em espaços exteriores poderá conduzir à falha do produto ou ferimentos pessoais. Atenção para não prender os dedos ao utilizar o suporte. Para obter assistência, contacte a equipa de apoio ao cliente através do número 1-800-865-2112.

▲ UYARI

TUR - Bu ürün aışşap kiriş veya masif beton tavanlara takılmak üzere tasarlanmıştır. Aışşap kirişin ve masif beton üstüne takılması için gereken aksesuar mevcuttur. Montaja başlamadan önce taşıyıcı yüzeyin hem takacağıınız donanımı hem de aksesuarı birlikte taşıyacağıından emin olunuz. Vidalar sağlam bir şekilde sıkıştırılmalıdır. Vidaları aşırı sıkımanız durumunda vidalara hasar verebilirsiniz ve ürün arızalanabilir. Azami Yük Kapasitesini asla aşmayınız. Ekipmanı güvenli bir şekilde kaldırmak ve yerleştirmek için her zaman başka birinden yardım alınız veya mekanik bir kaldırma donanımı kullanınız. Bu ürün yalnızca iç mekânlarda kullanılmak üzere imal edilmiştir. Bu ürünün dış mekânda kullanılması ürün arızalarına veya yaralanmalara sebep olabilir. Montaj sırasında parmaklarınızı sıkıştırmamaya dikkat ediniz. Destek almak için lütfen 1-800-865-2112 numaralı telefondan müşteri hizmetlerini arayınız.

ENG	Symbols
ESP	Símbolos
FRN	Symboles
DEU	Symbole
NEL	Symbolen
ITL	Simboli
ČEŠ	Symboly
SLK	Symboly
POR	Símbolos
TÜR	Semboller



ENG	WARNING
ESP	ADVERTENCIA
FRN	ADVERTISSEMENT
DEU	ACHTUNG
NEL	WAARSCHUWING
ITL	AVVERTENZA
ČEŠ	VÝSTRAHA
SLK	VÝSTRAHA
POR	AVISO
TÜR	UYARI



ENG	Skip to step.
ESP	Continúe con el paso.
FRN	Passez à l'étape.
DEU	Weiter mit Schritt.
NEL	Ga door naar stap.
ITL	Vai al passo.
ČEŠ	Přeskočte na krok.
SLK	Preskočte na krok.
POR	Saltar para o passo.
TÜR	Su adima geç.



ENG	Screws must get at least three full turns and fit snug.
ESP	Los tornillos tienen que dar, por lo menos, tres vueltas completas y quedar ajustados.
FRN	Il faut effectuer au moins trois tours de vis complets et bien serrer les vis.
DEU	Schrauben sind mindestens drei volle Umdrehungen einzudrehen und müssen fest anliegen.
NEL	De schroeven moeten ten minste drie hele slagen worden aangedraaid en stevig vastzitten.
ITL	Girare tre volte le viti che devono risultare aderenti.
ČEŠ	Šrouby se musí otočit minimálně tři plné otáčky a plně dosednout.
SLK	Skrutky sa musia otočiť aspoň tri celé otáčky a tesne dosadnúť.
POR	Os parafusos devem completar, no mínimo, três voltas completas e ajustar-se no local.
TÜR	Vidalara en az üç tam dönüş yapmalı ve sıkı oturmalıdır.

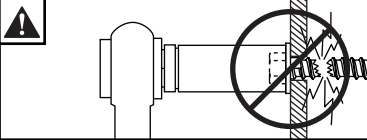

ENG	Do not overtighten screws.
ESP	No apriete de más los tornillos.
FRN	Ne pas trop serrer les vis.
DEU	Ziehen Sie die Schrauben nicht zu fest an.
NEL	Draai de schroeven niet te strak aan.
ITL	Non stringere troppo le viti.
ČEŠ	Šrouby neutahujte příliš silně.
SLK	Skrutky neutahujte príliš silno.
POR	Não apertar demasiado os parafusos.
TÜR	Vidaları gereğinden fazla sıkmayın.

ENG	Tools Needed for Assembly.
ESP	Herramientas necesarias para el ensamblaje.
FRN	Outils nécessaires au montage.
DEU	Für den Zusammenbau erforderliche Werkzeuge.
NEL	Voor montage benodigd gereedschap.
ITL	Attrezzi necessari per l'assemblaggio.
ČES	Nástroje potřebné k montáži.
SLK	Nástroje potrebné na montáž.
POR	Ferramentas necessárias para a montagem.
TÜR	Montaj İçin Gerekli Aletler.

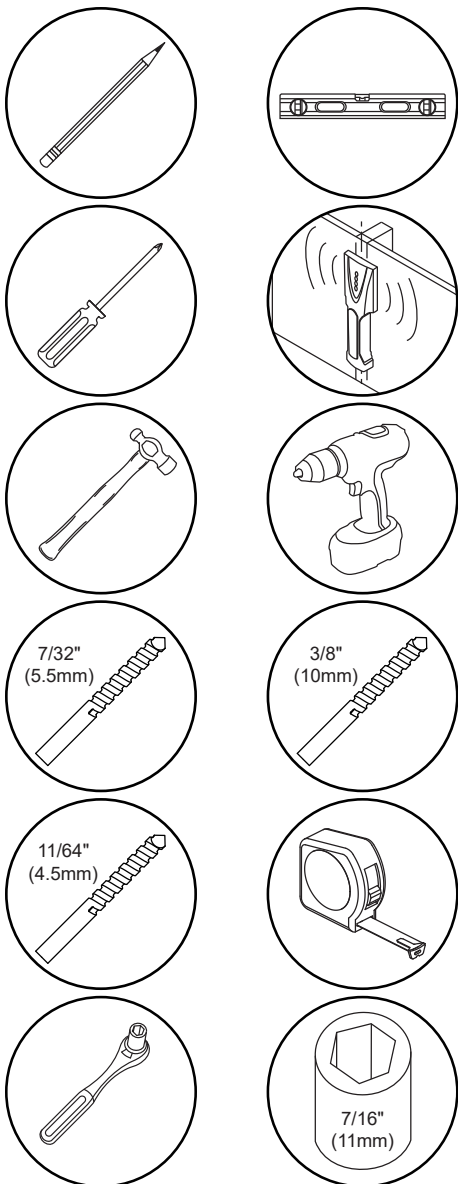

ENG	To properly tighten screws: Tighten until screw head makes contact, then tighten another 1/2 turn. Do not overtighten screws.
ESP	Apriete adecuado de los tornillos: Apriete hasta que la cabeza del tornillo haga contacto y luego apriete otra 1/2 vuelta. No apriete de más los tornillos.
FRN	Pour bien serrer les vis : Serrez jusqu'à ce que la tête de la vis entre en contact, puis serrez encore d'un 1/2 tour. Ne serrez pas trop les vis.
DEU	Korrektes Festziehen der Schrauben: Ziehen Sie die Schrauben fest, bis der Schraubenkopf Kontakt hat, und dann um eine weitere 1/2 Umdrehung. Ziehen Sie die Schrauben nicht zu fest an.
NEL	Ga als volgt te werk om de schroeven naar behoren aan te draaien: Draai de schroef aan totdat de kop het oppervlak raakt; maak daarna nog een halve slag. Draai de schroeven niet te strak aan.
ITL	Per stringere correttamente le viti: stringere fino a quando la testa della vite fa contatto, quindi stringere di un altro 1/2 giro. Non stringere eccessivamente.
ČES	Správné utažení šroubů: Utahujte, dokud se šroub nedostane do kontaktu, poté utáhněte ještě půl otočky. Šrouby neutahujte příliš silně.
SLK	Správne utiahnutie skrutiek: Utahujte, kým sa skrutka nedostane do kontaktu, potom utiahnite ešte pol otočky. Skrutky neutahujte príliš silno.
POR	Para apertar correctamente os parafusos: aperte até que a cabeça do parafuso esteja em contacto e, em seguida, aperte mais 1/2 volta. Não aperte demasiado os parafusos.
TÜR	Vidaları doğru bir şekilde sıkılmak için: Vida başı temas edene kadar döndürün, sonra yarım tur daha döndürün. Vidaları gereğinden fazla sıkılmayın.

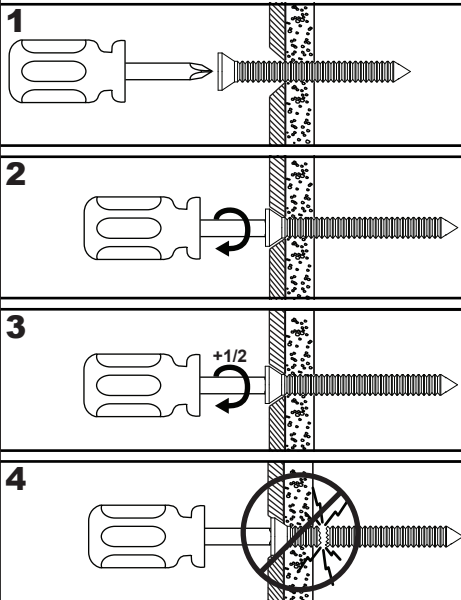

ENG	Parts (Before beginning, make sure you have all parts shown below).
ESP	Piezas (antes de iniciar, asegúrese de tener todas las piezas siguientes).
FRN	Pièces (avant de commencer, assurez-vous d'avoir toutes les pièces illustrées ci-dessous).
DEU	Teile (Achten Sie vor Beginn der Arbeiten darauf, dass alle unten abgebildeten Teile vorhanden sind).
NEL	Onderdelen (hoort u zich ervan te overtuigen dat u alle onderdelen hebt, die hieronder te zien zijn).
ITL	Parti (prima di iniziare, accertarsi di disporre tutte le parti sotto indicate).
ČES	Díly (předtím, než začnete, připravte si všechny díly zobrazené níže).
SLK	Diely (predtým, ako začnete, pripravte si všetky diely zobrazené nižšie).
POR	Peças (antes de iniciar, certifique-se de que tem todas as peças apresentadas em baixo).
TÜR	Parçalar (Başlamadan önce, aşağıda gösterilen bütün parçaların elinizde olduğundan emin olun).

Parts List		MOD-FCSKIT300 MOD-FCSKIT300-B
Description	Qty	Part #
A mounting plate	2	100-1120
B pole	1	100-5144 100-1068
C 5mm allen wrench	1	560-9640
D concrete anchor	8	590-0321
E wood screw	8	520-1243
F M8 x 55mm socket screw	2	520-1748
G M10 x 10mm set screw	2	520-0850
H 4mm allen wrench	1	560-9646
I pole clamp	2	100-1131
J M5 x 10mm socket pin screw	2	520-1164
K M5 x 16mm socket pin screw	2	520-1161
L tilt box	1	100-1069
M tilt plate	1	100-1047
N vertical plate	1	096-1437
O horizontal plate	2	096-1439
P plate nut	2	096-1440
Q M5 x 10mm socket pin screw	8	520-1063
R M5 x 10mm self-tapping phillips screw	1	520-9250
AA M4 x 12mm socket pin screw	4	520-1079
BB M4 x 25mm socket pin screw	4	520-1082
CC M6 x 12mm socket pin screw	4	520-1050
DD M6 x 25mm socket pin screw	4	520-1211
EE M8 x 12mm socket pin screw	4	520-1724
FF M8 x 25mm socket pin screw	4	520-1101
GG M4 washer	4	540-9400
HH M6/M8 washer	8	540-9406
II spacer	8	600-1215
JJ M8 x 50mm	4	521-1013

A (2)

mounting plate

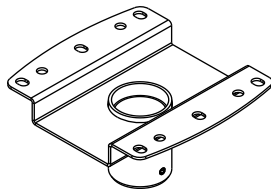

M (1)

tilt plate

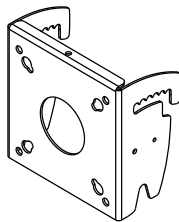

I (2)

pole clamp

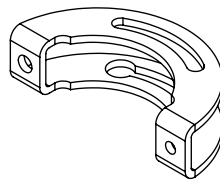

L (1)

tilt box

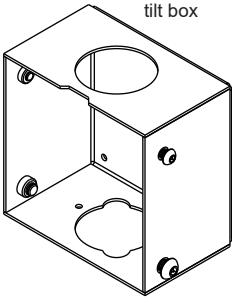

B (1)

pole

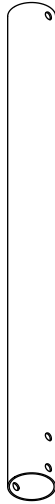

N (1)

vertical plate

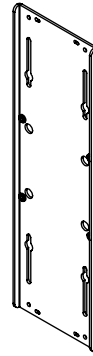

O (2)

horizontal plate

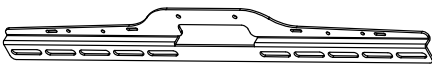

P (2)

plate nut



D (8)

10mm concrete anchor

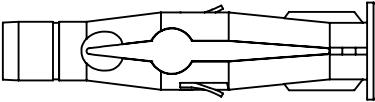

E (8)

3" wood screw

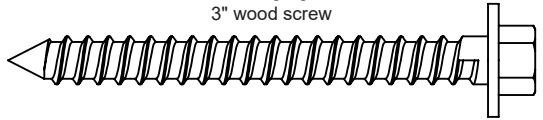

J (2)

M5 x 10mm

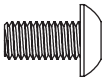

R (1)

M5 x 10mm
self-tapping

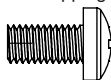

G (2)

M10 x 10mm

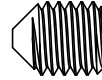

Q (8)

M5 x 10mm

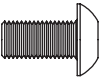

K (2)

M5 x 16mm



H (1)

4mm allen
wrench



F (2)

M8 x 55mm

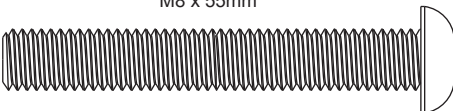

C (1)

5mm allen wrench

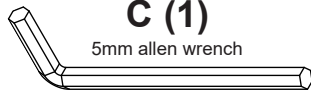

AA (4)
M4 x 12mm

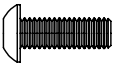

BB (4)
M4 x 25mm



CC (4)
M6 x 12mm

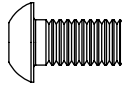

DD (4)
M6 x 25mm



EE (4)
M8 x 12mm

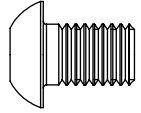

FF (4)
M8 x 25mm

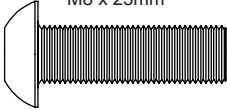

GG (4)
M4 washer

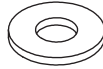

HH (8)
M6/M8 washer

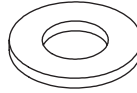

II (8)
spacer

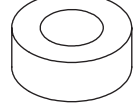

JJ (4)
M8 x 50mm

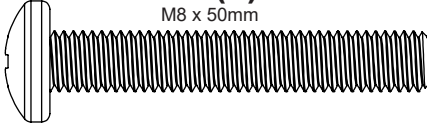

1-1

ENG	Optional: Cut pole to desired length. Cut end must be perpendicular to pole within 1/16" (1.5mm). Must use drill template MOD-ADF (sold separately) to drill new holes in pole. Refer to accompanying instructions.
ESP	Opcional: Corte el poste a la longitud deseada. El extremo cortado tiene que quedar perpendicular al poste a 1/16" (1.5mm). Tiene que utilizar la plantilla para taladro MOD-ADF (vendida por separado) para hacer los agujeros en el poste. Consulte las instrucciones incluidas.
FRN	Facultatif: Coupez le montant à la longueur souhaitée. L'extrémité coupée doit être perpendiculaire au montant, à 1/16 po (1,5mm) près. Vous devez utiliser le gabarit de perçage MOD-ADF (vendu séparément) pour percer de nouveaux trous dans le montant. Veuillez vous reporter aux instructions ci-jointes.
DEU	Facultativ: Schneiden Sie die Stange auf die gewünschte Länge zu. Das abgeschnittene Ende muss bis auf 1,5mm (1/16 Zoll) senkrecht zur Stange sein. Zum Bohren neuer Löcher in die Stange muss die (separat verkaufte) Bohrschablone MOD-ADF verwendet werden. Weiteres ist der beiliegenden Anleitung zu entnehmen.
NEL	Facultatief: Zaag de stang op de gewenste lengte. Het gezaagde uiteinde moet loodrecht zijn met een tolerantie van 1,5mm (1/16 inch). Voor het boren van de nieuwe gaten in de stang moet het boorsjabloon MOD-ADF (apart verkocht) worden gebruikt. Zie de bijgeleverde instructies.
ITL	Opzionale: Tagliare l'asta alla lunghezza desiderata. L'estremità tagliata deve essere perpendicolare all'asta entro 1.5mm. Per perforare nuovi fori nell'asta, è necessario usare la sagoma di perforazione MOD-ADF (venduta a parte). Vedere le istruzioni allegate.
ČES	Volitelné: Odřízněte tyč na požadovanou délku. Okraj řezu musí být kolmý k tyči s přesností 1,5mm. Na vrtání nových otvorů do tyče musíte použít vrtací šablonu MOD-ADF (prodává se samostatně). Viz příložený návod.
SLK	Voliteľné: Odrežte tyč na požadovanú dĺžku. Okraj rezu musí byť kolmý na tyč s presnosťou 1,5mm. Na vrtanie nových otvorov do tyče musíte použiť vrtaciu šablónu MOD-ADF (predáva sa samostatne). Rádte sa podľa priložených pokynov.
POR	Opcional: Corte o poste ao comprimento desejado. A extremidade deve ficar perpendicular ao poste a 1,5mm. Utilize o molde MOD-ADF (vendido em separado) para perfurar novos furos no poste. Consulte as instruções incluídas.
TÜR	İsteğe bağlı: Boruyu istenen uzunlukta kesiniz. Kesilen uç, boruya 1.5mm dikey gelmelidir. Boruda yeni delikler delmek için (ayrıca satılan) MOD-ADF delik delme şablonunu kullanmalısınız. Şablonla birlikte verilen talimatlara bkz.

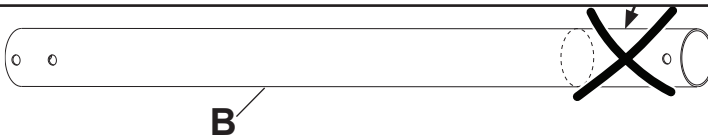

1-2

ENG	X = Distance from floor to ceiling.
ESP	X = Distancia desde el suelo hasta el techo.
FRN	X = Distance entre le plancher et le plafond.
DEU	X = Abstand vom Boden zur Decke.
NEL	X = Afstand van vloer tot plafond.
ITL	X = Distanza dal pavimento al soffitto.
ČEŠ	X = Vzdálenost od podlahy po strop.
SLK	X = Vzdialenosť od podlahy po strop.
POR	X = Distância do chão ao teto.
TÜR	X = Yerden tavana kadar mesafe.

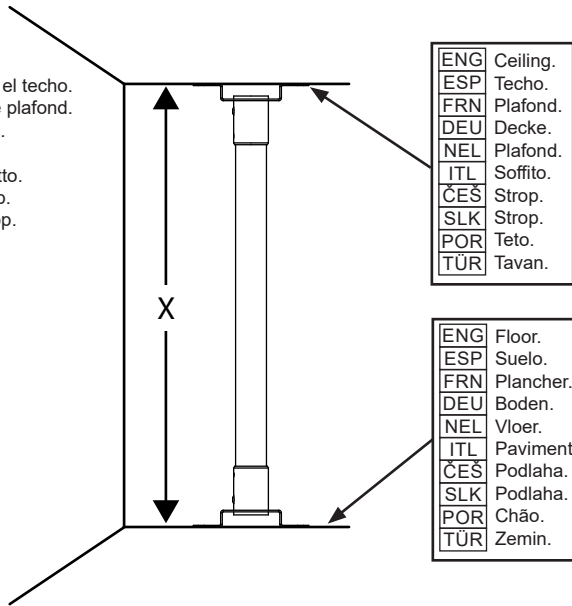

ENG	Ceiling.
ESP	Techo.
FRN	Plafond.
DEU	Decke.
NEL	Plafond.
ITL	Soffitto.
ČEŠ	Strop.
SLK	Strop.
POR	Teto.
TÜR	Tavan.

ENG	Floor.
ESP	Suelo.
FRN	Plancher.
DEU	Boden.
NEL	Vloer.
ITL	Pavimento.
ČEŠ	Podlaha.
SLK	Podlaha.
POR	Chão.
TÜR	Zemin.

1-3

ENG	Measure distance from floor to ceiling (X), subtract 4-1/8" (105mm) then mark pole and cut away excess material.
ESP	Mida la distancia desde el suelo hasta el techo (X), reste 4-1/8" (105mm), marque el poste y corte el exceso.
FRN	Mesurez la distance entre le plancher et le plafond (X), soustrayez 4-1/8 po (105 mm), puis marquez le montant et coupez l'excédent de longueur.
DEU	Messen Sie den Abstand vom Boden zur Decke (X), ziehen Sie 105 mm (4-1/8 Zoll) ab, markieren Sie dann die Stange und schneiden Sie überschüssiges Material ab.
NEL	Meet de afstand van vloer tot plafond (X), trek hiervan 105 mm af, markeer de paal en verwijder het overtollige materiaal.
ITL	Misurare la distanza dal pavimento al soffitto (X), sottrarre 105 mm, quindi contrassegnare il paletto e tagliare il materiale in eccesso.
ČEŠ	Odměřte vzdálenost od podlahy po strop (X), odpočítejte 4-1/8" (105 mm), potom poznačte tyč a odřežte nadbytečný materiál.
SLK	Odmerajte vzdialenosť od podlahy po strop (X), odpočítajte 4-1/8" (105 mm), potom poznačte tyč a odrežte nadbytočný materiál.
POR	Meça a distância do chão ao teto (X), subtraia 105 mm e, em seguida, marque o poste e corte o excesso.
TÜR	Yerden tavana kadar mesafeyi (X) ölçün, 4-1/8 inç (105mm) çıkarın, sonra direği işaretlemek ve fazla malzemeyi kesin.

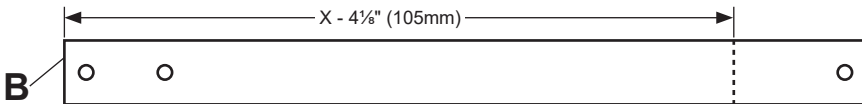

ENG	Reference MOD-P instructions for additional information
ESP	Consulte las instrucciones de los MOD-P para obtener más información
FRN	Reportez-vous aux instructions des modèles MOD-P pour plus de renseignements
DEU	Weitere Informationen können der Anleitung für die MOD-P entnommen werden
NEL	Zie de instructies voor MOD-P voor verdere informatie
ITL	Per ulteriori informazioni, vedere le istruzioni della piastra adattatore universale per schermi MOD-P
ČEŠ	V případě potřeby dalších informací si projděte pokyny MOD-P
SLK	Ak potrebujete ďalšie informácie, pozrite si pokyny MOD-P
POR	Consulte as instruções da MOD-P para obter informações adicionais
TÜR	Daha fazla bilgi için MOD-P talimatlarını bkz

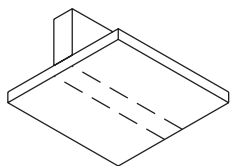
2

ENG	Wood joist/beam
ESP	Vigueta de madera
FRN	Solive de bois
DEU	Holz balken
NEL	Houten dwarsbalk
ITL	Travetto di legno
ČEŠ	Dřevěný nosník
SLK	Drevený nosník
POR	Trave de madeira
TÜR	Ahşap kiriş

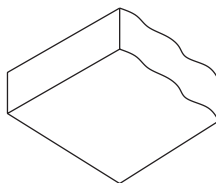
**2a**

ENG	Concrete Ceiling
ESP	Techo de concreto
FRN	Plafond en béton
DEU	Betondecke
NEL	Plafond van beton
ITL	Soffitto in calcestruzzo
ČEŠ	Betonový strop
SLK	Betónový strop
POR	Teto em betão
TÜR	Beton tavan

**2b****2a****▲ WARNING**

ENG - When installing Peerless ceiling mounts on a wood joist/beam covered with gypsum board (drywall), verify that the joists or beams are a minimum of 2" x 4" nominal size. Do not install over gypsum board thicker than 5/8".

▲ ADVERTENCIA

ESP - Cuando vaya a instalar soportes de techo de Peerless en viguetas / vigas de madera recubiertas con yeso-cartón (gypsum board) verifique que todos las viguetas / vigas tengan un tamaño mínimo de 2" x 4". No instale en yeso-cartón (gypsum board) de más de 5/8" de grosor.

▲ ADVERTISSEMENT

FRN - Lors de l'installation de supports de plafond Peerless sur des solives ou montants en bois recouverts de plaque de plâtre (cloison sèche), assurez-vous que ceux-ci ont une taille nominale d'au moins 2 po x 4 po (5 cm x 10 cm). Ne pas installer sur une plaque de plâtre dont l'épaisseur est supérieure à 5/8 po (16 mm).

▲ ACHTUNG

DEU - Bei der Anbringung von Peerless-Deckenhaltern an Holzträgern oder -balken mit Gipsplattenverkleidung (Trockenwand) muss darauf geachtet werden, dass die Träger bzw. Balken über eine Nenngröße von mindestens 51 x 102 mm (2 x 4 Zoll) verfügen. Das Produkt darf nicht an einer Gipsplatte mit einer Dicke von mehr als 15,9 mm (5/8 Zoll) angebracht werden.

▲ WAARSCHUWING

NEL - Als de Peerless-plafondbevestiging op een plafond bestaand uit houten balken/dwarsbalken en gipsplaat wordt geïnstalleerd, horen deze balken/dwarsbalken een afmeting van ten minste 5 x 10 cm te hebben. De plafondbevestiging mag niet worden geïnstalleerd op gipsplaat met een dikte van meer dan 15,88 mm.

▲ AVVERTENZA

ITL - In sede d'installazione dei sostegni Peerless su travi/traverse di legno ricoperte con muro a secco (cartongesso), verificare che le travi o le traverse abbiano una dimensione nominale minima di 5 cm x 10 cm. Non installare su cartongesso spesso più di 1,60 cm.

▲ VÝSTRAHA

ČEŠ - Při instalaci stropních držáků Peerless na dřevěný nosník/trám pokrytý sádrokartonovou deskou (sádrokartónem) zkontrolujte, zda nosníky nebo trámy mají minimální jmenovitý rozměr 5 x 10 cm. Nemontujte na sádrokartonovou desku hrubší než 1,6 cm.

▲ VÝSTRAHA

SLK - Pri montáži stropných držiakov Peerless na drevený nosník alebo trám pokrytý sadrovou doskou (sádrokartónom) skontrolujte, či nosníky alebo trámy majú minimálny menovitý rozmer 5 x 10 cm. Nemontujte na sádrokartón hrubší ako 1,6 cm.

▲ AVISO

POR - Ao instalar suportes para teto Peerless numa trave ou viga de madeira cobertas com painéis de gesso, verifique se as travessas ou vigas têm um tamanho nominal mínimo de 50,8 mm x 101,6 mm. Não instale em painéis de gesso com mais de 170 mm.

▲ UYARI

TÜR - Peerless tavan kaidelerini alçı panelle (alçıpan) kaplı ahşap bir kirişe monte ederken söz konusu kirişin nominal ebadının en azından 2" x 4" olmasına dikkat ediniz. 5/8" den daha kalın alçı panellerin üzerine monte etmeyiniz.

2a-1

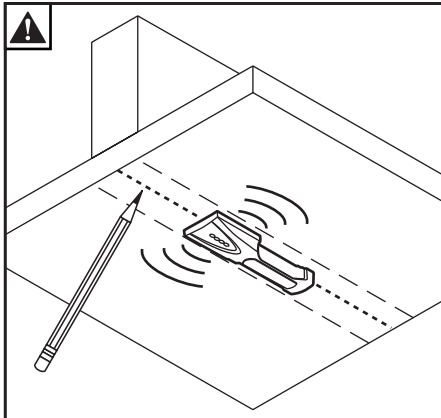
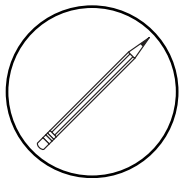
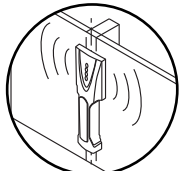

ENG Use stud finder to locate and mark stud center lines.

ESP Marque las líneas centrales del montante.

FRN Marquez la ligne médiane du montant.

DEU Markieren Sie die Ständer-Mittellinien.

NEL Markeer het midden van de balken.

ITL Contrassegna le linee centrali dei montanti.

ČES Vyznačte střední linii stěny.

SLK Vyznačte stredné čiary steny.

POR Marque as linhas centrais da escora.

TÜR Direk merkez hatlarını işaretleyin.

2a-2

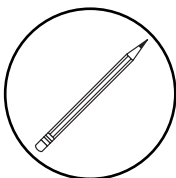
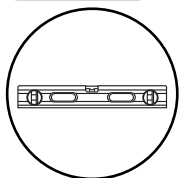

ENG Mark mounting holes on stud center lines.

ESP Marque los orificios de montaje en las líneas centrales del montante.

FRN Marquez les trous de fixation le long de la ligne médiane du montant.

DEU Markieren Sie die Montagelöcher auf den Ständer-Mittellinien.

NEL Markeer montagegaten op het midden van de balken.

ITL Contrassegna i fori di montaggio sulle linee centrali dei montanti.

ČES Na střední linii stěny vyznačte montážní otvory.

SLK Na stredné čiary steny vyznačte montážne otvory.

POR Marque os furos de montagem nas linhas centrais da escora.

TÜR Direk merkez hatları üzerinde montaj deliklerini işaretleyin.

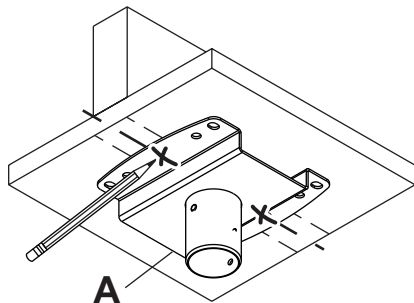

2a-3



- ENG** Drill mounting holes into supporting surface (3" (76mm) minimum depth required).
- ESP** Taladre los agujeros de montaje en la superficie de apoyo; se requiere una profundidad mínima de 3" (76mm).
- FRN** Percez les trous de fixation dans la surface de support, une profondeur minimale de 3 po (76mm) est requise.
- DEU** Bohren Sie Montagelöcher in die Montagefläche; Mindesttiefe von 76mm (3 Zoll) erforderlich.
- NEL** Boor montagegaten in het ondersteunende oppervlak met een diepte van ten minste 76mm.
- ITL** Trapanare I fori di sostegno nella superficie di supporto; profondità minima richiesta 76mm (3").
- ČES** Vytvřte montážní otvory do nosné plochy, minimální požadovaná hloubka je 76mm (3").
- SLK** Navŕtajte montážne otvory do nosnej plochy, minimálna vyžadovaná hĺbka je 76mm (3").
- POR** Perfure os furos de montagem na superfície de apoio, 76mm de profundidade mínima necessária.
- TÜR** Montaj deliklerini destekleyici yüzeye delin, 76mm (3 inç) minimum derinlik gereklidir.

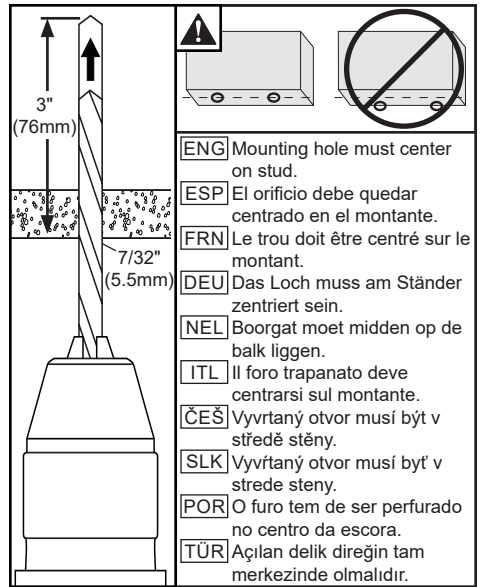

- ENG** Mounting hole must center on stud.
- ESP** El orificio debe quedar centrado en el montante.
- FRN** Le trou doit être centré sur le montant.
- DEU** Das Loch muss am Ständer zentriert sein.
- NEL** Boorgat moet midden op de balk liggen.
- ITL** Il foro trapanato deve centrarsi sul montante.
- ČES** Vytvřtaný otvor musí být v středě stěny.
- SLK** Vytvřtaný otvor musí byť v strede steny.
- POR** O furo tem de ser perfurado no centro da escora.
- TÜR** Açılan delik direğin tam merkezinde olmalıdır.

2a-4

- ENG** Install using wood screws provided.
- ESP** Nivele e instale.
- FRN** Mettez à niveau et procédez au montage.
- DEU** Waagrecht ausrichten und anbringen.
- NEL** Installeer de schroeven waterpas.
- ITL** Livella e installa.
- ČES** Vyrovnějte a namontujte.
- SLK** Vyrovnajte a namontujte.
- POR** Nivelar e instalar.
- TÜR** Dengeleyin ve takın.

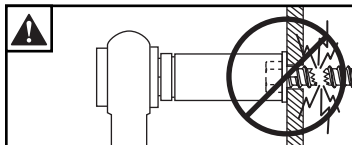
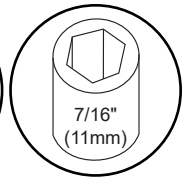
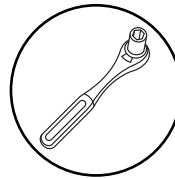

- ENG** Maximum 80 in. • lb (9 N.M.).
- ESP** Máxima 80 in. • lb (9 N.M.).
- FRN** Maximum 80 in. • lb (9 N.M.).
- DEU** Maximum 80 in. • lb (9 N.M.).
- NEL** Maximaal 80 in. • lb (9 N.M.).
- ITL** Massima 80 in. • lb (9 N.M.).
- ČES** Maximum 80 in. • lb (9 N.M.).
- SLK** Maximum 80 in. • lb (9 N.M.).
- POR** Máxima 80 in. • lb (9 N.M.).
- TÜR** Maksimum 80 in. • lb (9 N.M.).

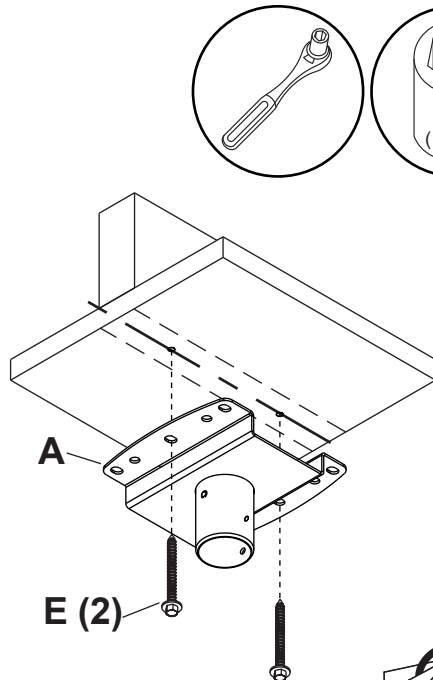

3-1

▲ WARNING

ENG - When installing Peerless ceiling mounts on a concrete ceiling, the ceiling must be at least 8" thick with a minimum compressive strength of 2000 psi. Never attach concrete expansion anchors to concrete covered with plaster, drywall, or other finishing material.

▲ ADVERTENCIA

ESP - Cuando vaya a instalar soportes de techo de Peerless en techos de concreto, los techos tienen que tener, por lo menos, 8" de grosor con una resistencia a la compresión de 2000 psi como mínimo. Nunca fije los anclajes de expansión para concreto a superficies de concreto recubiertas con yeso, yeso-cartón u otro material de acabado.

▲ ADVERTISSEMENT

FRN - Lors de l'installation de supports de plafond Peerless sur un plafond en béton, celui-ci doit avoir au moins 8 po (20 cm) d'épaisseur et une résistance à la compression d'au moins 2 000 psi. Ne fixez jamais des chevilles à expansion pour béton à du béton recouvert d'une couche de plâtre, d'une cloison sèche ou de tout autre matériau de finition.

▲ ACHTUNG

DEU - Werden Peerless-Deckenhalter an einer Betondecke angebracht, so muss deren Dicke mindestens 203 mm (8 Zoll) und ihre Druckfestigkeit mindestens 13,8 N/mm² (2000 psi) betragen. Betonspreizdübel dürfen auf keinen Fall an Beton befestigt werden, der mit Verputz, Trockenwand- oder anderem Deckschichtmaterial bedeckt ist.

▲ WAARSCHUWING

NEL - Als de Peerless-plafondbevestiging op een betonnen plafond wordt geïnstalleerd, moet dit plafond een dikte van ten minste 20 cm hebben en een druksterkte van ten minste 2000 psi. Gebruik nooit expansie-ankers voor beton bij installatie op een betonnen plafond bedekt met gips, gipsplaat of ander afwerkingsmateriaal.

▲ AVVERTENZA

ITL - In sede d'installazione dei sostegni Peerless su un soffitto in calcestruzzo solido, il soffitto deve avere uno spessore minimo di 20 cm, con una resistenza alla compressione di almeno 2000 psi (140 kg/cm²). Non attaccare mai ancoranti a espansione per calcestruzzo su calcestruzzo ricoperto con intonaco, cartongesso o altro materiale di finitura.

▲ VÝSTRAHA

ČEŠ - Při instalaci stropních držáků Peerless na betonový strop musí být tento strop hrubý minimálně 20 cm s minimální pevností v tlaku 2000 psi. Expanzní kotvy do betonu nikdy nepřipojujte do betonu pokrytého omítkou, sádkkartonem nebo jiným dokončovacím materiálem.

▲ VÝSTRAHA

SLK - Pri montáži stropných držiakov Peerless na betónový strop musí mať tento strop hrúbku minimálne 20 cm s minimálnou tlakovou pevnosťou 2000 psi. Expanzné kotvy do betónu nikdy nenasadzujte do betónu pokrytého omietkou, sadrokartónom či iným finalizačným materiálom.

▲ AVISO

POR - Ao instalar os suportes para o teto Peerless em tetos de betão, o teto deve ter, no mínimo, 203 mm de espessura e uma força de compressão mínima de 2000 psi. Nunca instale âncoras de expansão para betão em superfícies cobertas com estuque, gesso ou outros materiais de acabamento.

▲ UYARI

TÜR - Peerless tavan kaidelerini beton duvara monte ettiğinizde, tavan en azından 2000 psi asgari basınç dayanımına sahip olmalı ve kalınlığı da en azından 8" olmalıdır. Beton dübelleri hiç bir zaman alçı, alçıpan veya başka bir bitirme materyali ile kaplı betona takmayınız.

2b-1

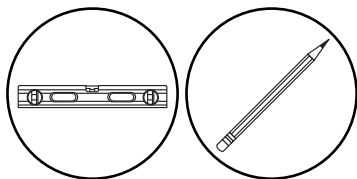

- ENG** Mark mounting holes.
ESP Marque los orificios de montaje.
FRN Marquez les trous de fixation.
DEU Markieren Sie die Montagelöcher.
NEL Markeer montagegaten.
ITL Contrassegna I fori di montaggio.
ČES Vyznačte montážní otvory.
SLK Vyznačte montážne otvory.
POR Marque os furos de montagem.
TÜR Montaj deliklerini işaretleyin.

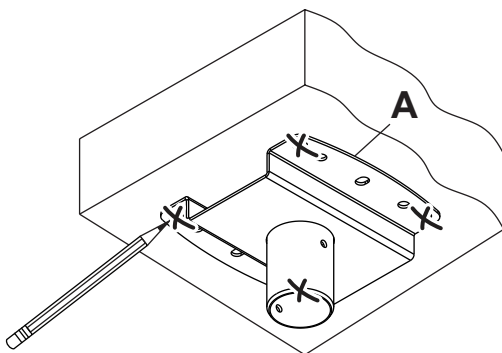

2b-2

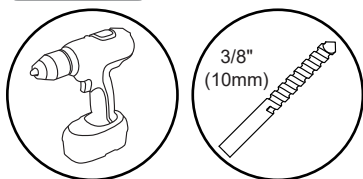

- ENG** Drill mounting holes into supporting surface (3" (76mm) minimum depth required).
ESP Taladre los agujeros de montaje en la superficie de apoyo; se requiere una profundidad mínima de 3" (76mm).
FRN Percez les trous de fixation dans la surface de support, une profondeur minimale de 3 po (76mm) est requise.
DEU Bohren Sie Montagelöcher in die Montagefläche; Mindesttiefe von 76mm (3 Zoll) erforderlich.
NEL Boor montagegaten in het ondersteunende oppervlak met een diepte van ten minste 76mm.
ITL Trapanare I fori di sostegno nella superficie di supporto; profondità minima richiesta 76mm (3").
ČES Vyrtejte montážní otvory do nosné plochy, minimální požadovaná hloubka je 76mm (3").
SLK Navrtajte montážne otvory do nosnej plochy, minimálna vyžadovaná hĺbka je 76mm (3").
POR Perfure os furos de montagem na superfície de apoio, 76mm de profundidade mínima necessária.
TÜR Montaj deliklerini destekleyici yüzeye delin, 76mm (3 inç) minimum derinlik gereklidir.

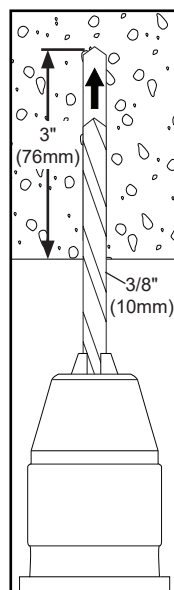

2b-3

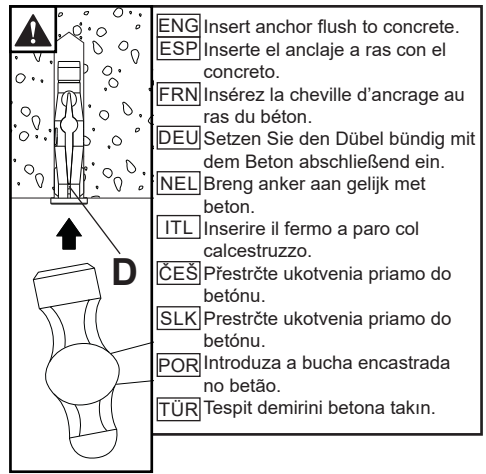
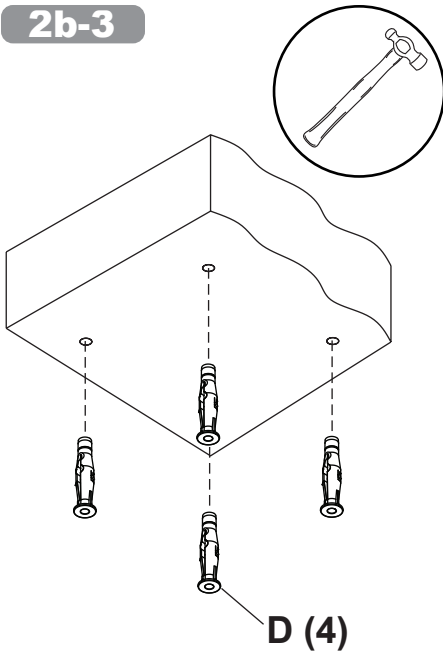

- | | |
|-----|---|
| ENG | Insert anchor flush to concrete. |
| ESP | Inserte el anclaje a ras con el concreto. |
| FRN | Insérez la cheville d'ancrage au ras du béton. |
| DEU | Setzen Sie den Dübel bündig mit dem Beton abschließend ein. |
| NEL | Breng anker aan gelijk met beton. |
| ITL | Inserire il fermo a paro col calcestruzzo. |
| ČES | Přestrčte ukotvení přímo do betónu. |
| SLK | Přestrčte ukotvení přímo do betónu. |
| POR | Introduza a bucha encastrada no betão. |
| TÜR | Teşpit demirini betona takın. |

D (4)

2b-4

- | | |
|-----|--|
| ENG | Install using concrete anchors and wood screws provided. |
| ESP | Nivele e instale. |
| FRN | Mettez à niveau et procédez au montage. |
| DEU | Waagrecht ausrichten und anbringen. |
| NEL | Installeer de schroeven waterpas. |
| ITL | Livella e installa. |
| ČES | Vyrovnejte a namontujte. |
| SLK | Vyrovnajte a namontujte. |
| POR | Nivelar e instalar. |
| TÜR | Dengeleyin ve takın. |

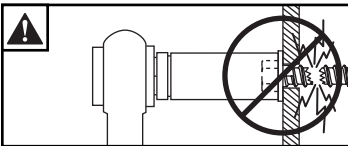
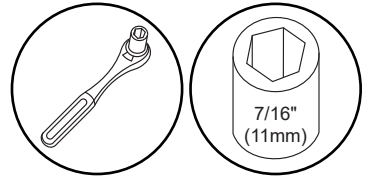

- | | |
|-----|--------------------------------|
| ENG | Maximum 80 in. • lb (9 N.M.). |
| ESP | Máxima 80 in. • lb (9 N.M.). |
| FRN | Maximum 80 in. • lb (9 N.M.). |
| DEU | Maximum 80 in. • lb (9 N.M.). |
| NEL | Maximaal 80 in. • lb (9 N.M.). |
| ITL | Massima 80 in. • lb (9 N.M.). |
| ČES | Maximum 80 in. • lb (9 N.M.). |
| SLK | Maximum 80 in. • lb (9 N.M.). |
| POR | Máxima 80 in. • lb (9 N.M.). |
| TÜR | Maksimum 80 in. • lb (9 N.M.). |

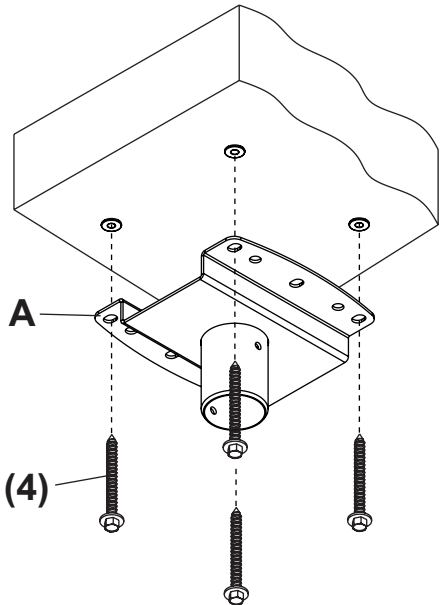

E (4)

3-1

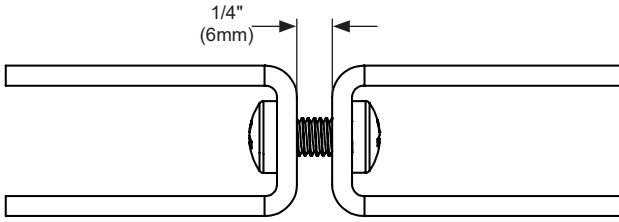
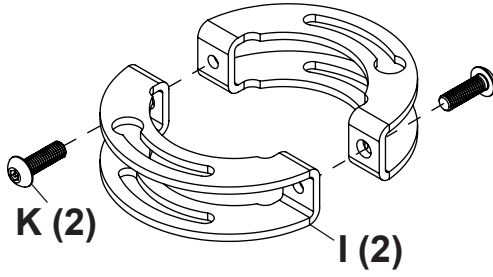

3-2

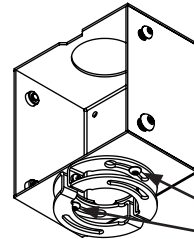
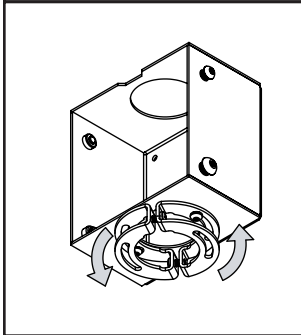
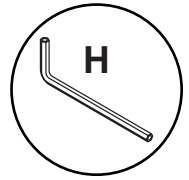
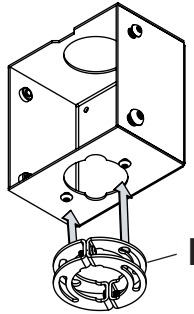
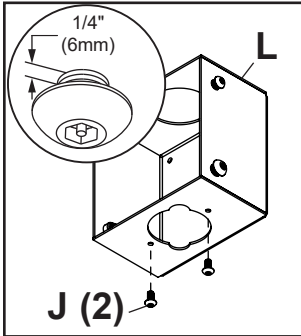

ENG	Tighten.
ESP	Apretar.
FRN	Serrer.
DEU	Anziehen.
NEL	Aandraaien.
ITL	Stringere.
ČES	Utáhněte.
SLK	Utiahnite.
POR	Apertar.
TÜR	Sıkmağ.

4

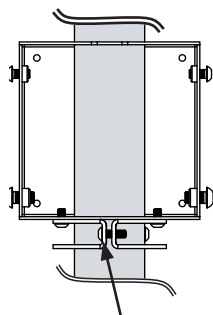
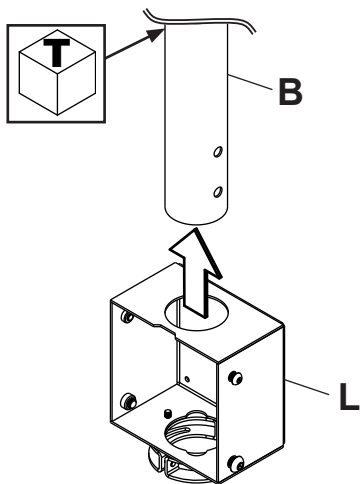

ENG	Tighten.
ESP	Apretar.
FRN	Serrer.
DEU	Anziehen.
NEL	Aandraaien.
ITL	Stringere.
CES	Utáhněte.
SLK	Utiahňte.
POR	Apertar.
TÜR	Sıkmak.

5-1

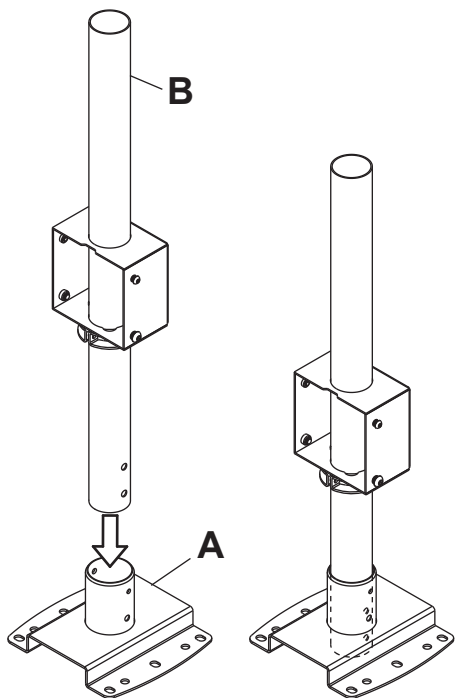

5-2

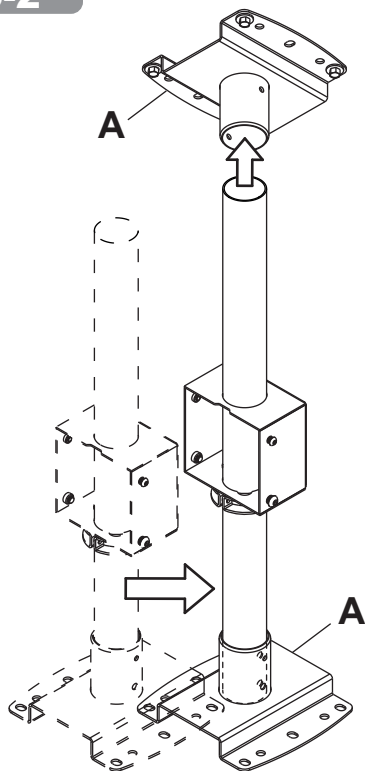

5-3

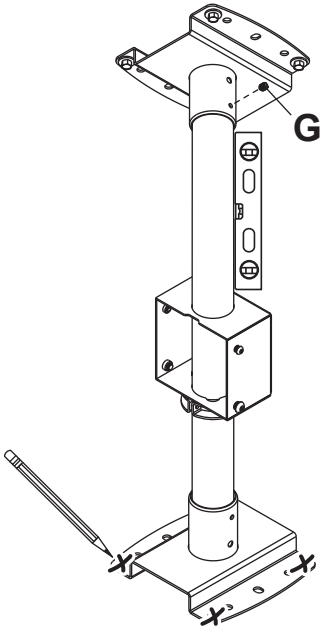

- ENG** Level, mark mounting holes then refer to step 2a or 2b to secure mounting plate to floor.
- ESP** Nivele, marque los agujeros de montaje y consulte el paso 2a o 2b para fijar la placa de montaje en el suelo.
- FRN** Mettez-la à niveau, marquez les trous de fixation, puis reportez-vous aux étapes 2a ou 2b pour fixer la plaque de montage au plancher.
- DEU** Richten Sie die Montageplatte waagrecht aus, markieren Sie die Montagelöcher und fahren Sie dann mit Schritt 2a oder 2b fort, um die Montageplatte am Boden zu befestigen.
- NEL** Zorg ervoor dat het geheel waterpas staat, markeer de montagegaten en zie dan stap 2a of 2b voor de montage van de bevestigingsplaat op de vloer.
- ITL** Livellare, contrassegnare i fori di montaggio, quindi vedere il passo 2a oppure 2b per fissare la piastra di montaggio al pavimento.
- ČEŠ** Vyrovnejte, vyznačte montážní otvory a potom podle kroku 2a anebo 2b zajistěte montážní desku k podlaze.
- SLK** Vyrovnejte, vyznačte montážne otvory a potom podľa kroku 2a alebo 2b zaistite montážnu dosku k podlahe.
- POR** Nivele, marque o furos de montagem e, em seguida, consulte o passo 2a ou 2b para obter a montagem segura da chapa ao chão.
- TÜR** Düzeltin, montaj deliklerini işaretleyin, sonra montaj plakasını yere sabitlemek için 2a veya 2b. adıma başvurun.



5-4

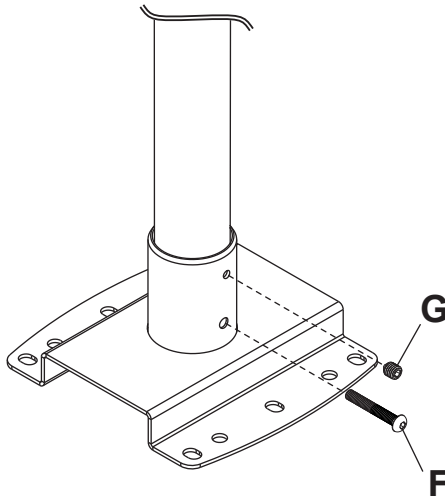
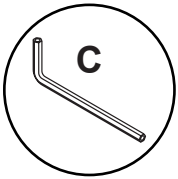

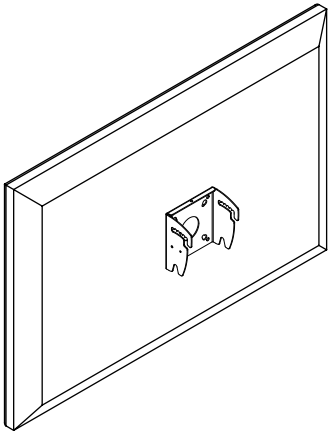
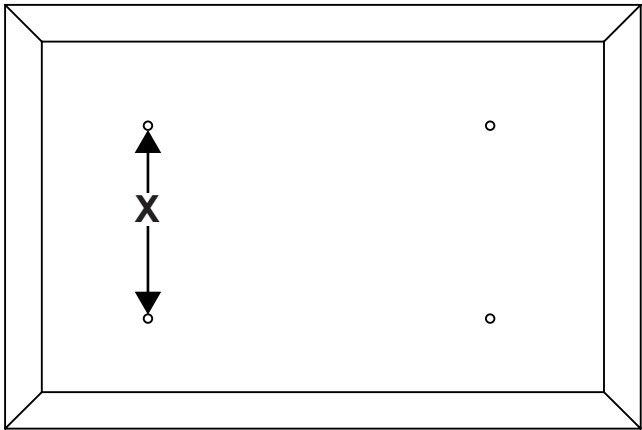

X = 75-100mm

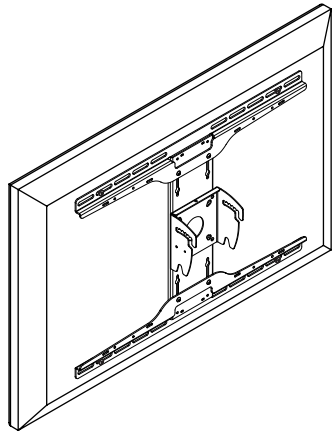

X = 100-200mm



X = 200-300mm



X = 300-400mm



6a

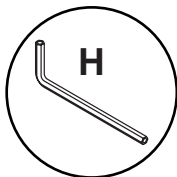

- ENG** Use of spacers and washers is optional.
- ESP** Uso de espaciadores y arandelas opcional.
- FRN** Facultatif utilisation d'entretoises de rondelles.
- DEU** Fakultativ verwendung von abstandhaltern und Waschmaschinen.
- NEL** Facultatief gebruik van tussenringen en ringen.
- ITL** Uso opzionale di distanziatori e rondelle.
- ČES** Voltitelné použití rozpěr distančních podložek.
- SLK** Voltiteľné použitie rozpierok dištančných podložiek.
- POR** Opcional utilize espaçadores e arruelas.
- TÜR** Ayırıcıların isteğe bağlı kullanımı ve yıkayıcı.

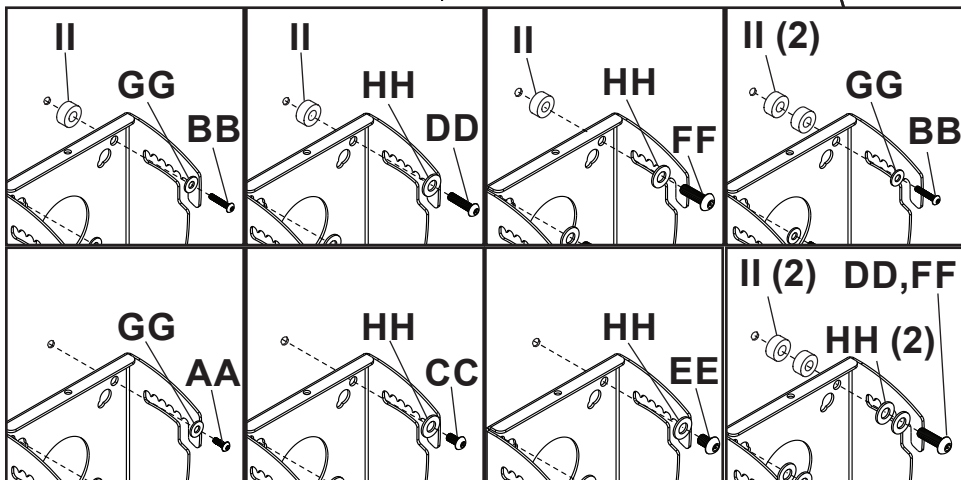
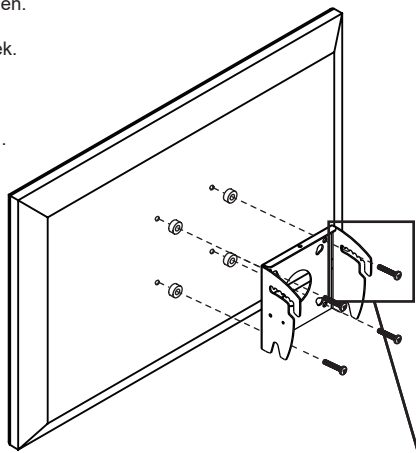

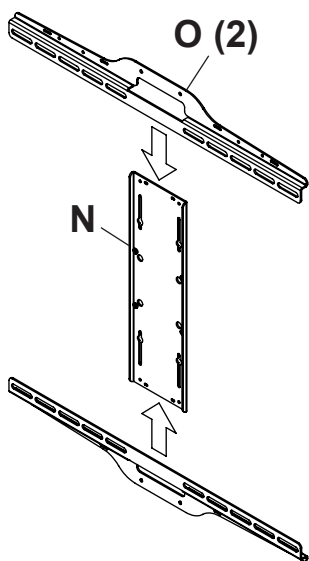
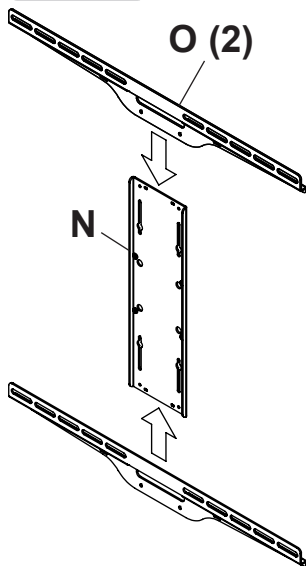
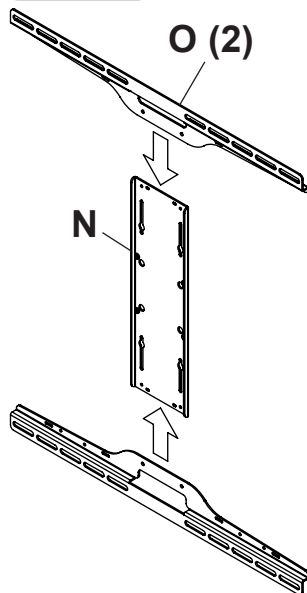
6b-1**6c-1****6d-1****6b-2**

ENG	Do not tighten the screws.
ESP	No apriete los tornillos.
FRN	Ne serrez pas les vis.
DEU	Ziehen Sie die Schrauben nicht an.
NEL	Schroeven niet aandraaien.
ITL	Non stringere le viti.
ČES	Šrouby neutahujte.
SLK	Skrutky neutahujte.
POR	Não apertar os parafusos.
TÜR	Vidaları sıkmayın.

6c-2

ENG	Do not tighten the screws.
ESP	No apriete los tornillos.
FRN	Ne serrez pas les vis.
DEU	Ziehen Sie die Schrauben nicht an.
NEL	Schroeven niet aandraaien.
ITL	Non stringere le viti.
ČES	Šrouby neutahujte.
SLK	Skrutky neutahujte.
POR	Não apertar os parafusos.
TÜR	Vidaları sıkmayın.

6d-2

ENG	Do not tighten the screws.
ESP	No apriete los tornillos.
FRN	Ne serrez pas les vis.
DEU	Ziehen Sie die Schrauben nicht an.
NEL	Schroeven niet aandraaien.
ITL	Non stringere le viti.
ČES	Šrouby neutahujte.
SLK	Skrutky neutahujte.
POR	Não apertar os parafusos.
TÜR	Vidaları sıkmayın.

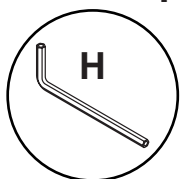
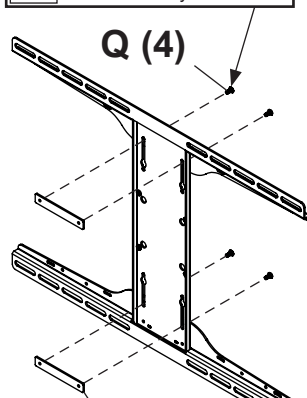
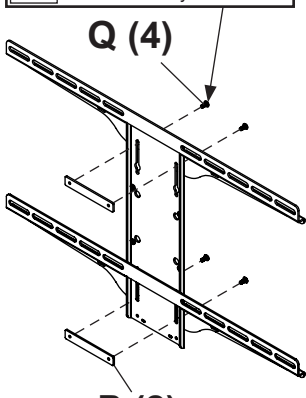
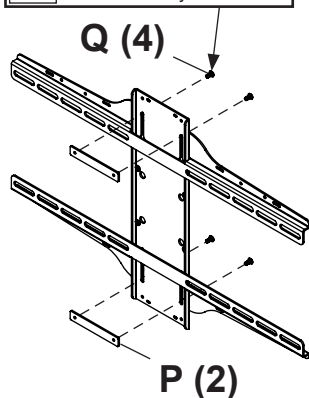

7-1

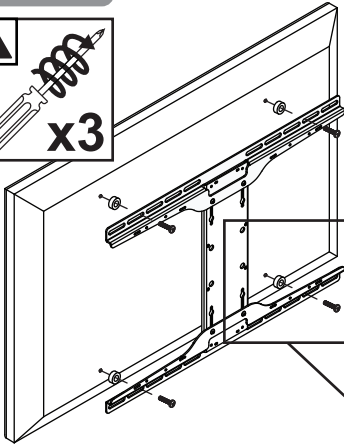
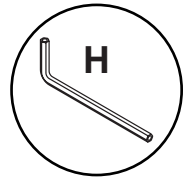

- ENG** Use of spacers and washers is optional.
ESP Uso de espaciadores y arandelas opcional.
FRN Facultatif utilisation d'entretoises de rondelles.
DEU Fakultativ verwendung von abstandhaltern und Waschmaschinen.
NEL Facultatief gebruik van tussenringen en ringen.
ITL Uso opzionale di distanziatori e rondelle.
ČES Volitelné použití rozpěr distančních podložek.
SLK Voliteľné použitie rozpierek distančných podložiek.
POR Opcional utilize espaçadores e arruelas.
TÜR Ayırıcıların isteğe bağlı kullanımı ve yıkayıcı.

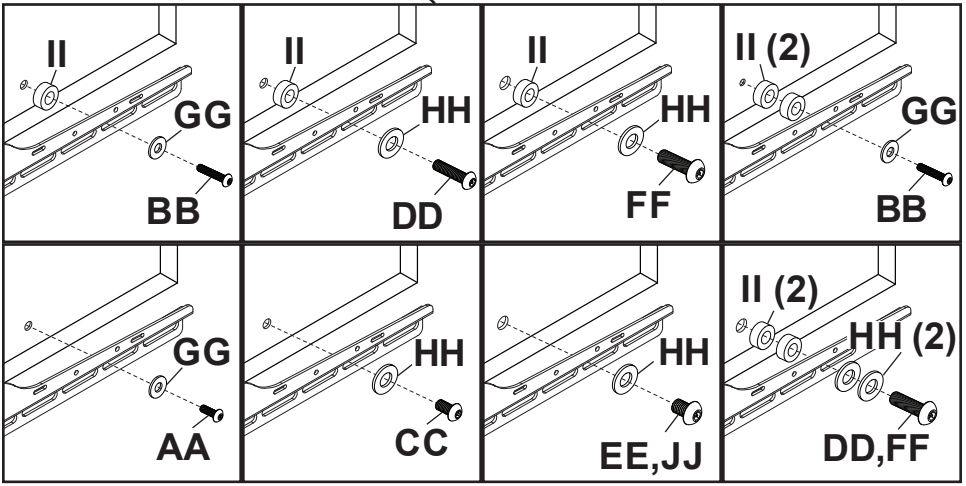

7-2

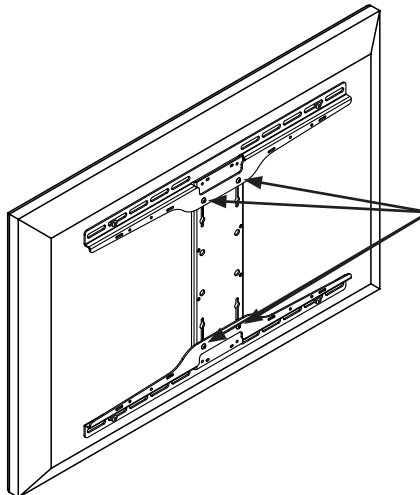
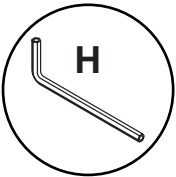

- 
ENG Tighten.
ESP Apretar.
FRN Serrer.
DEU Anziehen.
NEL Aandraaien.
ITL Stringere.
ČES Utáhněte.
SLK Utiahnite.
POR Apertar.
TÜR Sıkma.

7-3

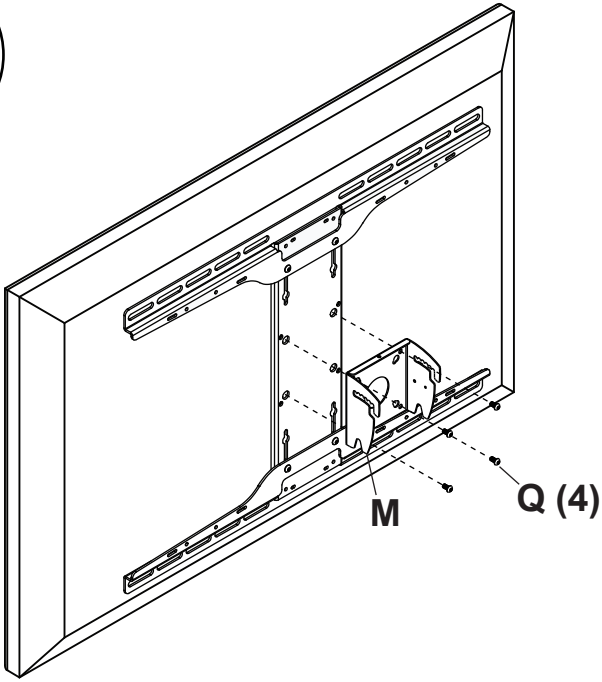
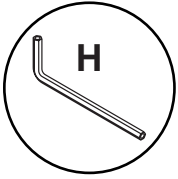

8a-1

ENG	Tilt limited by screen size.
ESP	La inclinación está limitada por el tamaño de la pantalla.
FRN	Inclinaison limitée par la taille de l'écran.
DEU	Die Neigung ist durch die Bildschirmgröße begrenzt.
NEL	Kanteling beperkt op basis van schermafmeting.
ITL	Inclinazione limitata dalla dimensione dello schermo.
ČEŠ	Sklon omezený rozměrem obrazovky.
SLK	Sklon obmedzený veľkosťou obrazovky.
POR	A inclinação é limitada pelo tamanho do ecrã.
TÜR	Dikey çevirme, ekran boyutuyla sınırlıdır.

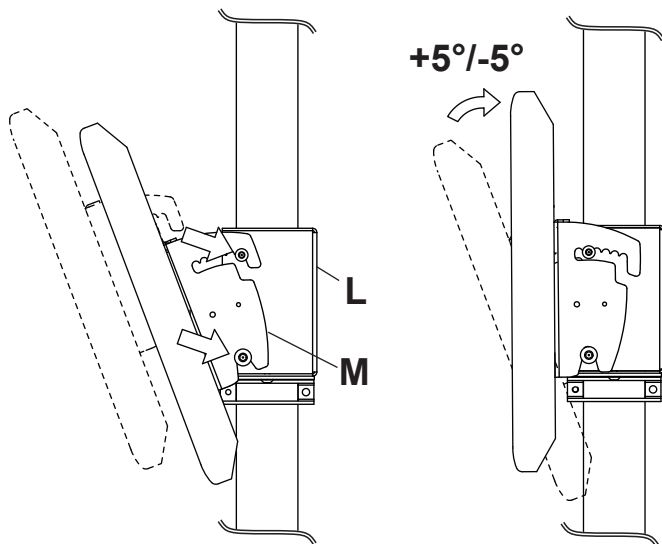

8a-2

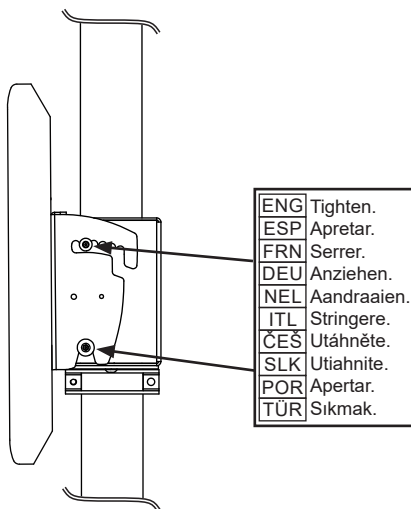
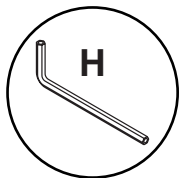

9-1

8b-1

- ENG** Optional. Remove top screws if screen interferes with attaching tilt plate.
- ESP** Opcional. Quite los tornillos superiores si la pantalla interfiere con la fijación de la placa inclinable.
- FRN** Facultatif. Retirez les vis supérieures si l'écran empêche la fixation de la plaque d'inclinaison.
- DEU** Fakultativ. Entfernen sie die oberen schrauben, falls der bildschirm das anbringen der kipplatte behindert.
- NEL** Facultatief. Verwijder de bovenste schroeven als het scherm problemen geeft bij het bevestigen van de kantelplaat.
- ITL** Opzionale. Rimuovere le viti in alto se lo schermo ostacola l'installazione della piastra d'inclinazione.
- ČES** Volitelné. Odstraňte horní šrouby, pokud se obrazovka střetává s přípojní sklopnou deskou.
- SLK** Voliteľné. Ak obrazovka zasahuje do prichytávacej sklopnej dosky, odstráňte vrchné skrutky.
- POR** Opcional. Remover os parafusos superiores se o ecrã interferir com a afixação da chapa de inclinação.
- TÜR** İsteğe bağlı. Ekran, bağılandığı dikey eğme levhasına engel oluyorsa üstteki vidaları çıkarın.

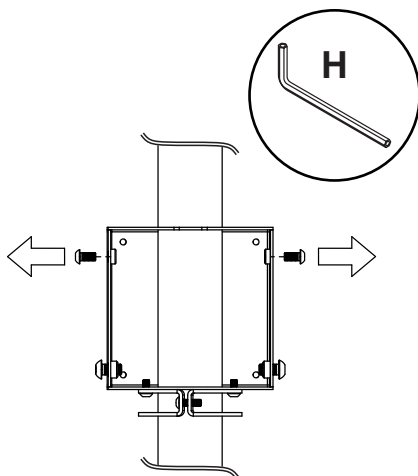

8b-2

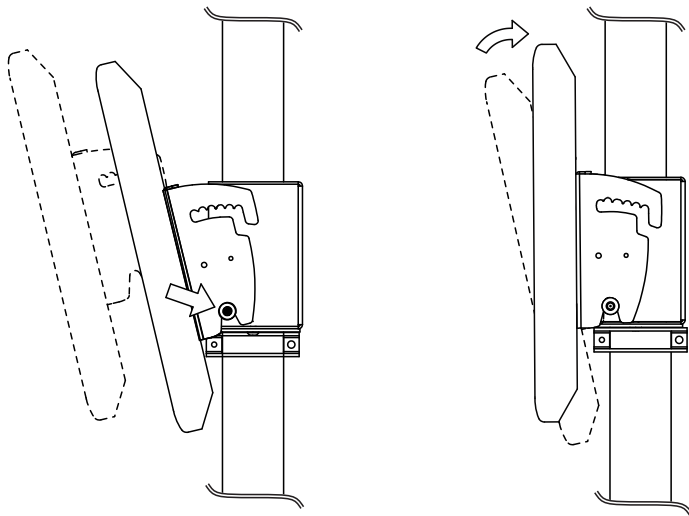

8b-3

- ENG** Tighten all screws.
- ESP** Apriete todos los tornillos.
- FRN** Serrez toutes les vis.
- DEU** Ziehen Sie alle Schrauben an.
- NEL** Alle schroeven aandraaien.
- ITL** Stringere tutte le viti.
- ČES** Přitáhnout všechny šrouby.
- SLK** Pritiahnuť všetky skrutky.
- POR** Aperte todos os parafusos.
- TÜR** Tüm vidaları sıkın.

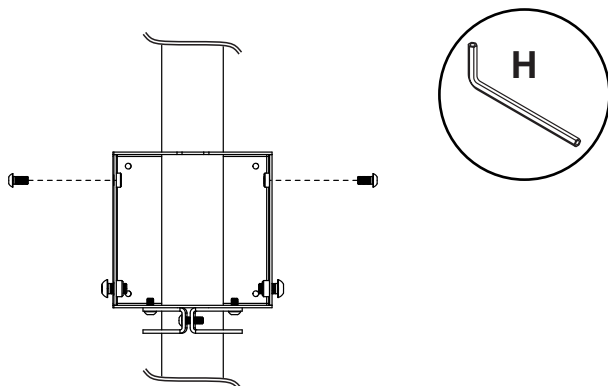

9-1

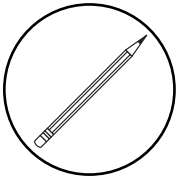

- | | |
|-----|-----------------------------------|
| ENG | Mark drill hole. |
| ESP | Marque los orificios de montaje. |
| FRN | Marquez les trous de fixation. |
| DEU | Markieren Sie die Montagelöcher. |
| NEL | Markeer montagegaten. |
| ITL | Contrassegna i fori di montaggio. |
| ČES | Vyznačte montážní otvory. |
| SLK | Vyznačte montážne otvory. |
| POR | Marque os furos de montagem. |
| TÜR | Montaj deliklerini işaretleyin. |

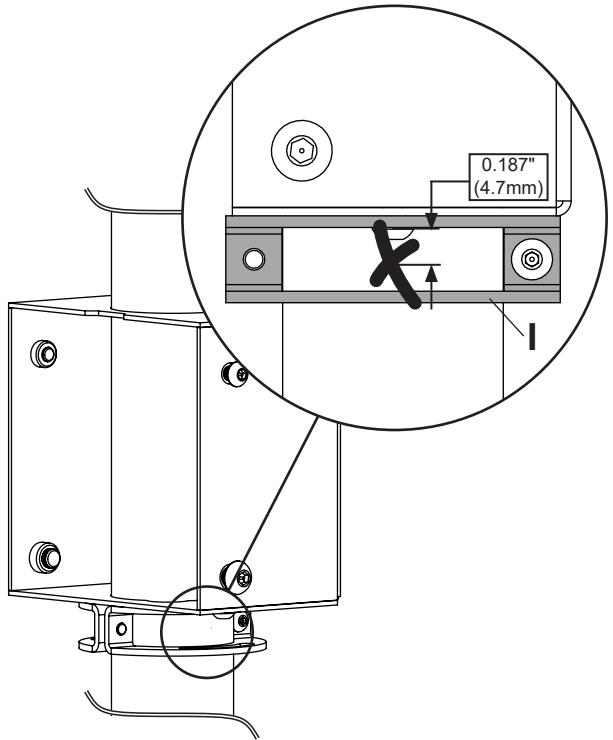

9-2

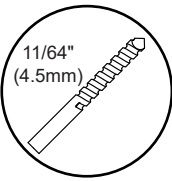

- | | |
|-----|---------------------|
| ENG | Drill hole. |
| ESP | Perforar hoyos. |
| FRN | Percez un trou. |
| DEU | Bohrloch. |
| NEL | Boren gat. |
| ITL | Perforare il pozzo. |
| ČES | Vyvrtaný otvo. |
| SLK | Vyvrtaný otvo. |
| POR | Perfurar buraco. |
| TÜR | Matkap delik. |

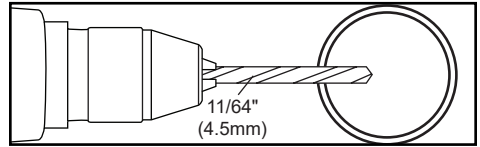

9-3

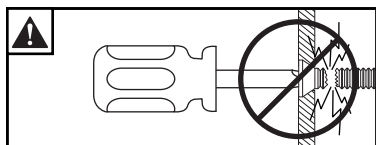
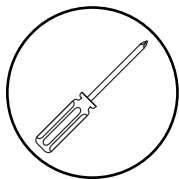

ENG	Do not overtighten screws.
ESP	No apriete de más los tornillos.
FRN	Ne pas trop serrer les vis.
DEU	Ziehen Sie die Schrauben nicht zu fest an.
NEL	Draai de schroeven niet te strak aan.
ITL	Non stringere troppo le viti.
ČES	Šrouby neutahujte příliš silně.
SLK	Skrutky neutahujte príliš silno.
POR	Não apertar demasiado os parafusos.
TÜR	Vidaları gereğinden fazla sıkmayın.

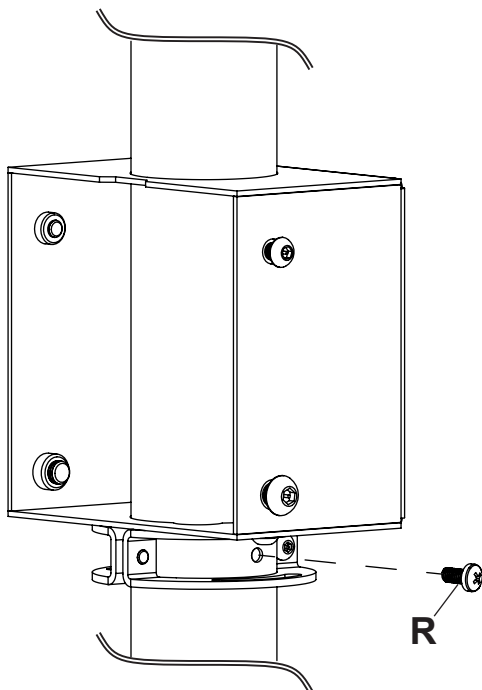

ENG Warranty
ITL Garanzia

ESP Garantía
ČEŠ Záruka

FRN Garantie
SLK Záruka

DEU Garantie
POR Garantia

NEL Garantie
TÜR Garanti

www.peerless-av.com/warranty

peerless-AV[®]

Peerless-AV

2300 White Oak Circle
Aurora, IL 60502
Email: tech@peerlessmounts.com
Ph: (800) 865-2112
Fax: (800) 359-6500
www.peerless-av.com

© 2020, Peerless Industries, Inc.

Peerless-AV Europe

Unit 3 Watford Interchange,
Colonial Way, Watford, Herts,
WD24 4WP, United Kingdom
Customer Care
44 (0) 1923 200 100
www.peerless-av.com

© 2020, Peerless Industries, Inc.

Peerless-AV América Latina

Av. de las Industrias 413
Parque Industrial Escobedo
General Escobedo N.L., México 66062
Servicio al Cliente
01-800-849-65-77
www.peerless-av.com

© 2020, Peerless Industries, Inc.