

*FOR THE WINNERS' CIRCLE*



**ANDASEAT**  
**NOVIS SERIES USER MANUAL**

ASSEMBLY INSTRUCTIONS AND USER GUIDE



Thank you for choosing AndaSeat!  
Before using this product, please read this manual carefully  
and keep it available for future reference.

## PACKAGE CONTENTS

---

- 1X Backrest
- 1X Seatbase
- 1X Wheel Base
- 2X Armrests
- 1X Tilt Mechanism
- 2X Side Covers
- 5X Casters (wheels)
- 12X M8 Screws (2pcs Spare Screws)
- 2X M6 Screws
- 1X Long Allen Key
- 1X Gas Piston+Sleeve

# ASSEMBLY GUIDE

## 1. Install the Casters

Flip the wheelbase over and press the casters into the wheelbase.



## 2. Install the Gas Piston

Turn the wheelbase right side up, then insert the gas piston in the middle and cover it with the sleeve.



## 3. Install the Armrests

Mount the armrests to the seat with M8 screws and washers. Make sure to correctly identify the left and right armrests.



## 4. Unscrew the Backrest

Remove the 4 pre-installed M8 screws from the backrest using the included Allen key.



## 5. Attach the Backrest - Right Side

Slide the backrest into the seat's right recline bracket. Insert the previously removed M8 screws and tighten them halfway.



## 6. Attach the Backrest - Left Side

Align the seat's left recline bracket with the backrest. Insert the previously removed M8 screws and tighten them halfway. Then fully tighten all the screws on both left and right sides.



## 7. Attach the Side Covers

Fix the side covers over the brackets using the M6 screws. Make sure to correctly identify the left and right covers.



## 8. Set the Chair Facing Down

Gently lift the chair and put it facing down.



### 9. Attach the Tilt Mechanism

Align the tilt mechanism with the bottom of the seat base. Insert four M8 screws halfway to hold it in place, then tighten them fully using the Allen key.  
Reminder: Make sure the FRONT sign is aligned with the seat front.



### 10. Attach the Wheelbase

Lift the assembled wheelbase and insert the gas piston into the seat base.



### 11. Put the Chair Up

Carefully turn the chair upright to complete the assembly.



## HOW TO ADJUST

### 155° Backrest Recline

Pull the recline lever fully and hold it, lean back gently to your desired angle, then release the lever to lock in place.



### Armrests

Press and hold the armrest buttons to move up and down.



### Armrest-to-armrest Width

Loosen the M8 screws on the armrest mounts, adjust the armrests to the desired width, then tighten the screws to secure them.



### Tilt Tension

Turn the tension knob clockwise to loosen or counterclockwise to tighten. Adjust based on weight, and avoid turning past its limits.



### Tilt Mechanism

Height Adjustment (While seated): Pull the lever up to adjust the seat height.  
Tilt Lock & Unlock (While seated): Push the lever in to lock and out to unlock the tilt angle.

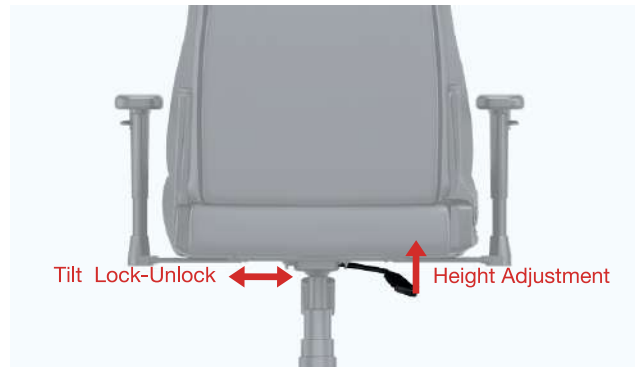

# SAFETY INSTRUCTION

### Recommended Size

Chair Size	L	XL
Recommended Weight	35 - 90kg (77 - 198lbs)	35 - 120kg (77 - 265lbs)
Recommended Height	155 - 190cm (5'1" - 6'3")	165 - 210cm (5'5" - 6'11")

**Failure to follow these instructions may result in serious personal injury or property damage.**

1. Do not use the chair for purposes other than the manufacturer originally intended.
2. Do not stand on the chair as a ladder.
3. Do not have more than one person on the seat.
4. Do not sit on the edge of the seat.
5. Do not place the chair near flammables.
6. Place it in a dry and cool place.
7. Avoid exposing the chair to direct sunlight or other heat sources.
8. It is recommended to mount the chair on a soft surface to avoid damage to the upholstery.
9. Use soft and dry cloth for general cleaning and maintenance of the chair. Do not apply corrosive chemicals on the chairs.
10. When transporting the product, proceed with caution.
11. Any modifications and changes of product components that could void your warranty.



Sit in the center of the chair.



Do not stand on the chair.



Do not use the chair with more than one person.



Do not use rocking mode over weight limit.



Do not push the chair around when a person is sitting in it.



Do not push down on the backrest when a person is reclined.



Do not place all your weight on the backrest only.



Do not place your hand or fingers near the recline mechanism.

For warranty information, please visit our Warranty & Return Policy:

<https://www.andaseat.com/pages/warranty>

If you have any questions or need any assistance, please contact: [sales-support@andaseat.com](mailto:sales-support@andaseat.com)