

# W03381

## 3300 Watts Generator

# FIRMAN®

Whisper series

Running / Starting Watts: 3300/3650

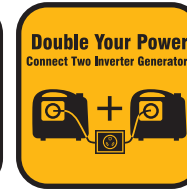
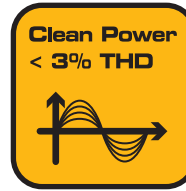

## Features & Benefits

- Fuel Economy Mode - reduces fuel consumption and promotes engine efficiency.
- The FIRMAN 193cc OHV engine (Max-Pro Series) for longer life/higher performance/lower maintenance.
- Cast iron sleeved engine for long durability with automatic low oil shutdown protection.
- Largest tank in industry with extended run-time (less re-fueling).
- Quiet muffler (Whisper Series) with USDA FS certified spark arrester.
- Conveniently located multi-featured control panel with FIRMAN custom designed outlet cover protecting outlets from dirt, dust and debris.
- 3 in 1 Data-Minder monitors running hours, voltage and frequency in conjunction.
- Bonus accessories including engine oil, oil funnel, tool kit and battery charge cable.
- 3 year warranty: best in industry.

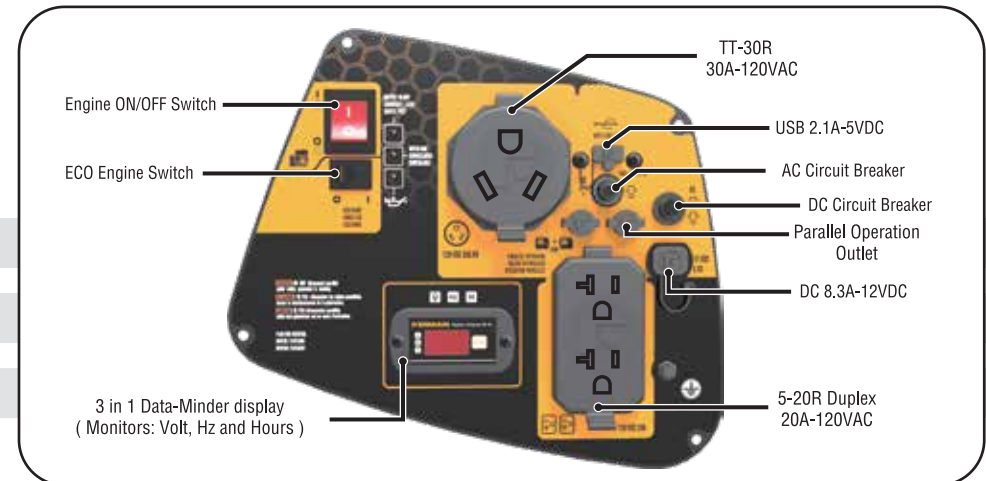

# W03381

## 3300 Watts Generator

# FIRMAN®

### Whisper series

### Specification

Model /Rev Level	W03381 / 00
UPC	840876133811
50 States	Yes
California (CARB)	Yes
Canada (CETL)	Yes
Running Watts	3300
Starting Watts	3650
Voltage (Volts)	120
Frequency (Hz)	60
Engine Displacement (cc)	193
Engine Type	OHV
Starting System	Recoil
Cylinder	Single
Fuel Type	Gasoline
Low Oil Shutdown	Yes
Cast Iron Sleeve	Yes
Brushed or Brushless Alternator	Permanent Magnet
Inverter	Yes
Fuel Tank Volume (Gal)	1.8
Fuel Gauge	No
Runtime @25% load (hours)	9.0
USDA FS Certified Spark Arrester	Yes



Battery	No
Accessories	Oil Bottle-Funnel-Tool Kit -Battery Charger Cable
Warranty Residential / Commercial (years)	3 Yrs Ltd / 90 Days
Carton LxWxH (inch)	26.6 x 18.9 x 19.3
Unit Weight (lbs)	87
Shipping Weight (lbs)	97

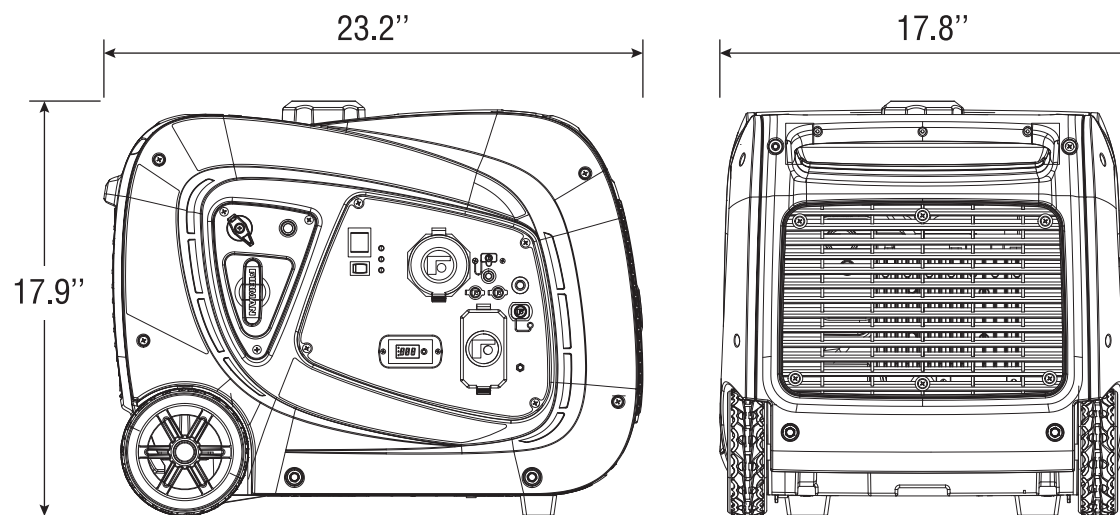

**FIRMAN**

8716 West Ludlow Dr. Suite #6  
Peoria, AZ 85381

1-844-FIRMAN1 (1-844-347-6261)

www.firmanpowerequipment.com