

Table of Contents

Introduction	2
Overview	2
Features	3
Package Contents	4
Specifications	4
Panel Description	8
Installation and Wiring	10
Installation	11
Wiring	11
Auto Switching	13
Button Control	13
RS232 Operation	14
Device Control	14
Control 3rd-party Device	15
TCP to RS232 routing	16
LAN Control	16
Obtain the IP Address of the Device	16
Telnet	17
Log in to the Web UI	17
Reset password and IP mode	18
Web UI	18
Dante Introduction	36

Introduction

Overview

This product is a 4x2 conference presentation switcher, it is specially designed for conference room scenarios, featuring various models and specifications to meet diverse user needs. It supports 4x2 matrix switching and optional long-distance video, audio, and USB transmission via HDBT 3.0 technology.

Equipped with dual USB-C full-featured and dual HDMI+USB 3.0 inputs, it can connect multiple laptops or desktop computers. It supports 4 local USB 3.0 device ports, enabling connection to various USB conference devices such as USB cameras, audio-bars, and USB speakers, and can extend USB connectivity over long distances via HDBT.

The presentation switcher offers flexible audio configuration, allowing HDMI audio, USB audio, and Dante audio to be output through a local balanced audio output port, also with the option to output conference audio to remote Dante-supported devices through the Dante port.

The presentation switcher supports multiple control interfaces, including RS232, GPIO, RELAY, and Sensor interfaces, for seamless integration with various controlled devices. With complete network functionality, it provides 2 independent RJ-45 interfaces and supports USB-to-Ethernet functions.

Through the VLAN division and 802.1x, switcher and USB networks can be separated to meet security requirements. The presentation switcher provides multiple switching options, including automatic switching, manual switching, and configuration priority switching. It also supports HTTP and HTTPS configuration, 802.1x security, CEC and RS232 configuration, customized GPIO function, and comes with built-in Web UI and API control.

It can be utilized either as a standalone device or connected to third-party control systems, making it easy for users to integrate into their system solutions.

Features

- 4x2 conference presentation switch, integrating video, audio, USB, control and ethernet.
- Inputs and outputs support resolutions up to 5120x2160@30Hz and 5120x1440@60Hz.
- Dual USB-C and dual HDMI + USB 3.2 inputs, and all ports support cable lock connections.
- Full-featured USB-C inputs, supports 5120x2160@30Hz and 5120x1440@60Hz video, USB 3.2 data, USB ethernet and 60W charging.
- One USB-C input supports MST for dual-screen conferencing applications.
- Supports automatic switching, USB and video independent switching, priority switching, and other switching methods.
- Provides 4 USB 3.2 device ports for connecting conference equipment, such as cameras and speakerphone.
- Provides one balanced audio out port for connecting audio equipment, supports audio de-embedding, UAC, and Dante.
- Provides 100m HDBT 3.0 output for video and USB extension applications in medium and large conference rooms.
- Provides RS232, GPIO, RELAY, and OCS Sensor ports to connect various control and controlled devices.
- One USB charge-only port is connected to the conference table to provide a charging function for mobile phones.
- Each input port provides an independent USB to Ethernet bridge, providing a 1G ethernet connection to the connected computer.
- Provides two independent RJ-45 ports for ethernet switch or VLAN Setting.
- Supports one RJ-45 port for 2x2 Dante.
- Supports ethernet control, supports HTTP and HTTPS, and supports 802.1x authentication.

Package Contents

- 1 x Matrix Switcher
- 1 x DC 20V/10A Power Adapter
- 1 x AC Power Cord with US Pins
- 2 x USB 3.2 Type-C to Type-C Cable (L = 2m)
- 2 x USB 3.0 Type-A to Type-B Cable (L = 1.8m)
- 1 x 3.5mm 3-Pin Phoenix Male Connector
- 2 x 3.5mm 3-Pin Phoenix Male Connector (Double Layer)
- 1 x 3.5mm 5-Pin Phoenix Male Connector
- 1x 3.5mm 6-Pin Phoenix Male Connector
- 4 x Mounting Brackets (with Screws)

Specifications

Technical	
Input/Output Port	2 x HDMI IN, 2 x USB-C IN, 2 x HDMI OUT, 1 x HDBT, 2 x USB HOST (USB Type-B), 1 x AUDIO OUT (3.5mm, 5-pin phoenix connector), 4 x USB DEVICE (USB Type-A), 2 x RS232, 1 x GPIO (3.5mm, 6-pin phoenix connector), 2 x RELAY, 1 x SENSOR, 2 x ETHERNET (RJ45), 1 x DANTE (RJ45), 1 x DC 20V
Input/Output Signal Type	HDMI with 5K Ultrawide Resolutions (5120x2160@30Hz) and 5K Super-wide Resolutions (5120x1440@60Hz), HDCP 2.2/1.4.
USB HOST IN 1 & 2	Supports USB 3.2 Gen 2x1 standard, up to 10Gbit/s
USB-C IN 3&4	USB-C IN 3: USB-C supports USB 3.2 Gen 2x1 standard, and supports: <ul style="list-style-type: none"> • Video: DP alt mode, SST only, up to 5120x2160@30Hz and 5120x1440@60Hz. • USB data: Up to 10Gbit/s. • Charging: 60W.

Technical	
	USB-C IN 4: USB-C supports USB 3.2 Gen 2x1 standard, and supports: <ul style="list-style-type: none"> • Video: DP alt mode, MST dual output, up to 5120x2160@30Hz and 5120x1440@60Hz. • USB data: Up to 10Gbit/s. • Charging: 60W.
USB DEVICE	Maximum supports USB 3.2 Gen 2x1 standard, up to 10Gbit/s. 5V/1.5A output per port.
Input/Output Resolution Supported	VESA: 800 x 6006, 1024 x 7686, 1280 x 7686, 1280 x 8006, 1280 x 9606, 1280 x 10246, 1360 x 7686, 1366 x 7686, 1440 x 9006, 1600 x 9006, 1600 x 12006, 1680 x 10506, 1920 x 12006, 2048 x 11526, 2560 x 14406, 3440 x 14406, 5120x14403,6, 5120x21603
	CTA: 1280x720P5,6, 1920x1080P1,2,3,4,5,6 , 3840x2160P1,2,3,4,5,6, 4096x2160P1,2,3,4,5,6 1 = at 24 (23.98) Hz, 2 = at 25 Hz, 3 = at 30 (29.97) Hz, 4 = at 48 Hz, 5 = at 50 Hz, 6 = 60 (59.94) Hz
HDR	All HDR formats, including HDR 10, HLG, HDR 10+ and Dolby Vision

Audio Format	<ul style="list-style-type: none"> • USB-C IN/HDMI IN/ HDMI OUT: Up to 7.1ch, including PCM 2.0/5.1/7.1ch, Dolby Digital, Dolby Digital Plus, Dolby TrueHD, Dolby Atmos, DTS 5.1, DTS-HD Master Audio and DTS:X. • Audio de-embedding: Stereo only. • Dante: Stereo only.
ETHERNET	1000M/100M adaptive network
Maximum Data Rate	USB-C IN: 10Gbit/s (per lane) HDMI: 18Gbps USB 3.2: 10Gbit/s
Control Method	Front Panel Buttons, RS232, LAN (Telnet & Web UI)

General	
Operating Temperature	0°C to 45°C (32°F to 113°F)
Storage Temperature	-20°C to 70°C (-4°F to 158°F)
Humidity	10% to 90%, non-condensing
ESD Protection	Human-body Model: ±8kV (Air-gap discharge)/

General	
	±4kV (Contact discharge)
Power Supply Power	DC 20V, 10A
Consumption (Max)	Without USB and Charging: 13.1W With USB + Charging: 155.6W
Device Dimension (W x H x D)	325mm x 25mm x 180.2mm / 12.80" x 0.98" x 7.09" (without mounting brackets)
Product Weight	1.45kg/3.20lbs

Transmission Distance

Note:

- T568B straight-through category cable is recommended.
- Please use F/FTP or U/FTP cable, and don't use UTP, F/UTP, or U/UTP cables.

Cable Type	Range	Supported Video
Cat 5e/6	70m/230ft	4K@60Hz 4:2:0 24bpp 4K@30Hz 1080P@60Hz
	40m/131ft	4K@60Hz 4:4:4 24bpp 4K@60Hz 4:2:2 36bpp 5120x2160@60Hz 4:2:0 5120x1440@60Hz 4:4:4
Cat 6A (U/FTP)	100m/330ft	4K@60Hz 4K@30Hz 1080P@60Hz 5120x2160@60Hz 4:2:0 5120x1440@60Hz 4:4:4

Use Patches

Note:

Patches may be used in the installation, and the patches will obviously affect the transmission distance. Limits and distances are as follows:

- Support up to 2 patch cables, each not exceeding 5m.
- Patches must be installed on both ends of the device, refer to the following pictures:

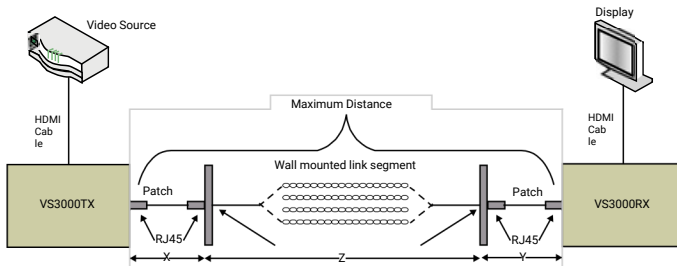

The standard specifies the following lengths for the three-segment cable installation:

- X = Left-side patch cable length ≤ 5 [meter]
- Y = Right-side patch cable length ≤ 5 [meter]
- Z = Wall segment \leq Maximum Distance - X - Y [meter]

Cable Type	Range	Supported Video
Cat 5e/6	70m/230ft (with Patches)	4K@60Hz 4:2:0 24bpp 4K@30Hz 1080P@60Hz
	30m/100ft (with Patches)	4K@60Hz 4:4:4 24bpp 4K@60Hz 4:2:2 36bpp
Cat 6A (U/FTP)	70m/230ft (with Patches)	4K@60Hz 4:4:4 24bpp 4K@60Hz 4:2:2 36bpp
	100m/330ft (with Patches)	4K@60Hz 4:2:0 24bpp 4K@30Hz 1080P@60Hz

Cable Type	Range	Supported Video
USB Type-C to USB Type-C Cable (USB 3.2 Gen 2, 10Gbps per lane)	2m/7ft	1080P@60Hz 24bpp 4K@30Hz 4:4:4 24bpp 4K@60Hz 4:2:0 24bpp 4K@60Hz 4:4:4 24bpp
HDMI	Input/Output: 10m/33ft	1080P@60Hz 24bpp 4K@30Hz 4:4:4 24bpp 4K@60Hz 4:2:0 24bpp
	Input/Output: 5m/16ft	4K@60Hz 4:4:4 24bpp

Panel Description

Front Panel

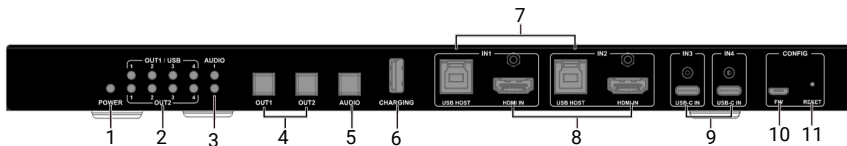

ID	Name	Description
1	POWER LED	<ul style="list-style-type: none"> On: The device is powered on. Off: The device is powered off.
2	OUTPUT 1 / USB LEDs and OUTPUT 2 LEDs	<ul style="list-style-type: none"> Red: USB devices are connected to the corresponding USB host. Green: The corresponding video input is selected or the corresponding video input and USB host are selected. Off: The corresponding input are not selected.
3	AUDIO 1&2 LEDs	<ul style="list-style-type: none"> On: The corresponding de-embedded audio from HDMI OUT 1/2 is selected as source. Off: The corresponding de-embedded audio from HDMI OUT 1/2 is not selected as source for AUDIO OUT.
4	OUTPUT 1&2 Selection Button	Press the button to select input source for HDMI OUT 1/2.

5	AUDIO OUT Selection Button	Press the button to switch the audio source between the de-embedded audio from HDMI OUT 1 and HDMI OUT 2 for AUDIO OUT port.
6	Charging	USB 2.0 Type-A port. 5V/2A USB charging.
7	USB HOST 1&2	<p>USB 3.2 type-B ports. Connect to USB HOST devices.</p> <ul style="list-style-type: none"> • USB HOST 1 and USB HOST 2 are bound with HDMI IN 1 and HDMI IN 2 respectively. • The two ports support Ethernet bridge, the laptop connected to the two ports can

ID	Name	Description
		access the network the ETHERNET ports connected. The two USB Host ports and two USB type-C ports share 1G network.
8	HDMI IN	Connect to HDMI sources.
9	INPUT 3&4 (USB-C IN)	<p>USB 3.2 type-C ports. Connect to USB-C sources.</p> <p>The two full-featured USB-C ports support the following three functions:</p> <ul style="list-style-type: none"> • Supports audio, video and USB signal transmission, maximum 10Gbit/s data rate. • USB-C IN 3 and 4 support DP SST, one video output with 4K signal transmission; • USB-C IN 4 supports DP MST, two video outputs with 4K signal of each channel transmission; • Supports PD 3.0, and can supply up to 60W power for the connected device; • Supports 1G network connection, the laptop connected with these ports can access the Ethernet the matrix connected; <p>The following cable are recommended to use: USB Type-C to Type-C cable (USB 3.2 Gen 1x1 or above)</p>
10	FW	Micro-USB port. For ARM firmware upgrade.
11	RESET	<p>Insert a tool such as a needle.</p> <ul style="list-style-type: none"> • Press and hold it for about 5s: Reset the IP settings, including reset the IP mode to DHCP, and reset the login password to "admin". • Press and hold it for about 15s: Reset the device to factory defaults.

Rear Panel

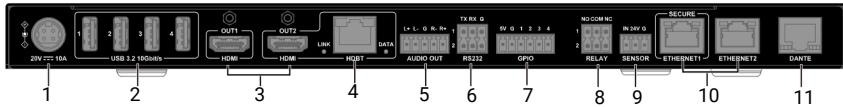

ID	Name	Description
1	20V/10A	Connect to the power adapter provided.
2	USB DEVICE	USB 3.2 type-A ports, 5V/1.5A output per port. Connect to USB devices such as camera and speakerphone.
3	HDMI OUT (1~2)	Connect to the HDMI display devices. HDMI OUT 2 is mirrored with HDBT port.
4	HDBT	Connect to an HDBT 3.0 receiver such as EX0101-N628-000.
5	AUDIO OUT	Connect to an audio receiver.
6	RS232 1 & 2	<ul style="list-style-type: none"> RS232 1: Connect to a RS232 control device for API control or connect to a 3rd party device for RS232 routing. RS232 2: Connect to a RS232 3rd party device for RS232 routing.
7	GPIO	Connect to GPIO devices. The device supports connecting to 6 GPIO devices.
8	RELAY 1 & 2	Connect to relay devices for relay control.
9	SENSOR	Connect to OCS sensor.
10	ETHERNET 1 (SECURE) & 2	Connect to a network device (e.g., network switch, router, computer, etc.) for LAN control (Web UI & Telnet). VLAN function can be configured via API commands and web UI, please refer to the separate document "API Command Set_MS0402-N011-000" or " Network " part in "Web UI" section.
11	Dante	Connect to the network for Dante audio connection.

Installation and Wiring

Warnings:

- Before installation and wiring, disconnect power from the device.
- During wiring, connect and disconnect the cables gently.

Installation

1. Attach the bracket to one side of the enclosure using the screws provided. The bracket is attached to the enclosure as shown.

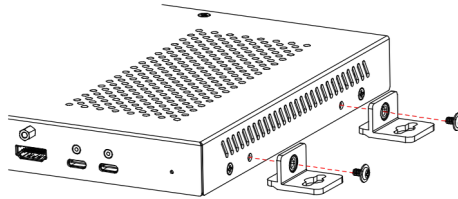

2. Repeat step 1 for the other side of the enclosure.
3. Attach the brackets to the surface or location desired using screws (not included in the package).

Wiring

Wiring 1: 4x2 Presentation Switch with Dual Screen mode

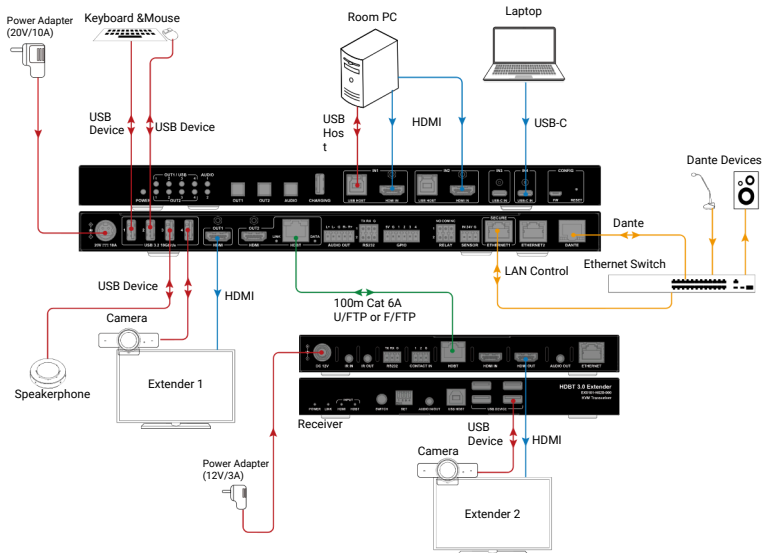

Note: By default, USB-C IN 4 is in DP SST mode, use the command “SET USB4_DM MST<CR><LF>” or refer to web UI page (see the separate document “API Command Set_MS0402-N011-000” or refer to “Switch” part in “Web UI” section) to set the USB-C IN 4 to MST mode. In this mode, the USB-C IN 3 is disabled, and the USB-C IN 4’s source can transmit two video signals with 4K each to the two HDMI outputs respectively.

Wiring 2: 4x2 Presentation Switch with matrix mode

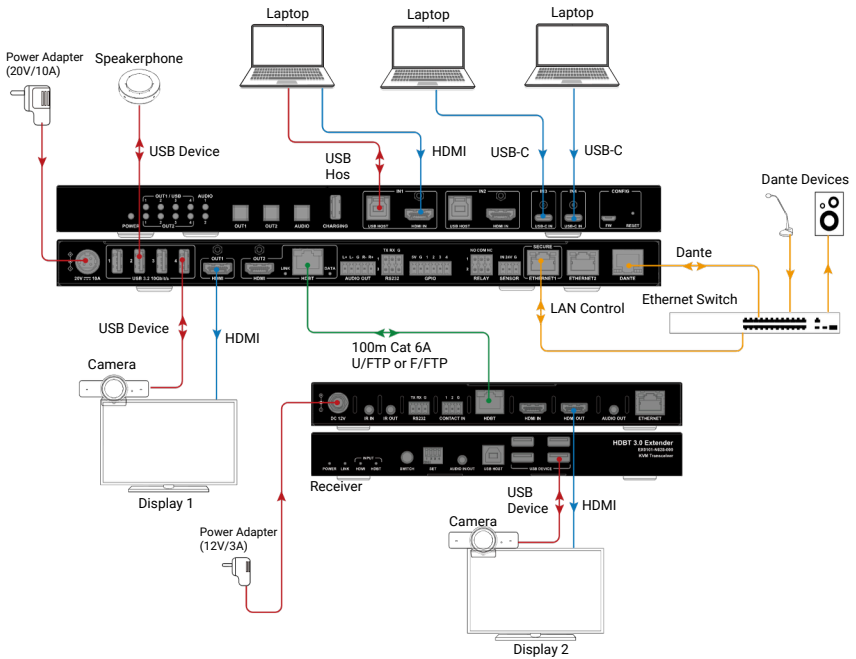

Auto Switching

The device supports automatic switching (HDMI and USB-C video and USB) and provides two modes:

- LIFO mode.
- Priority mode.

This function can be enabled/disabled through Web UI or API Commands.

Note:

1. Please refer to “Switch” part in the “Web UI” section or separate document “API Command Set_MS0402-N011-000” to get detailed configuration information.
2. Video switching to detect valid signals, and USB switching to detect VBUS.

Button Control

Users can perform basic switching of input sources to outputs and audio source selection.

- **OUT 1** button: Press the button continuously to switch the input source for **HDMI 1** output. The LED will light when the corresponding source is selected.

Note: The default mode of the USB switch is "**Follow video out 1**", using the "**OUT 1**" button will switch the video out 1 and the USB device at the same time.

- **OUT 2** button: Press the button continuously to switch the input source for output 2, including HDMI 2 and HDBT 3.0 outputs. The LED will light when the corresponding source is selected.
- **AUDIO** button: Select the audio de-embedding from which output,

OUT 1 or **OUT 2**. The LED will light when the corresponding audio source is selected. Note: Audio routing can be set via the Web UI and API, refer to the separate document "*API Command Set_MS0402-N011-000*" or "**Audio Routing**" part in "Web UI" section for details.

RS232 Operation

The device provides two RS232 ports for device control or control of 3rd-party devices.

Supported functions are as follows:

- **RS232-1:**
 - Device control (API).
 - Control 3rd-party device.
 - TCP to RS232 routing.
- **RS232-2:**
 - Control 3rd-party device.
 - TCP to RS232 routing.

Device Control

Users may need to control the device via API commands. Connect an RS232-enabled device (such as a PC) to the **RS232-1** port. For detailed command information, please refer to the separate document "*API Command Set_MS0402-N011-000*". Before sending API commands to control the device, ensure the serial ports between this device and the PC are configured correctly. A professional RS232 serial interface software (e.g., Serial Assist) may be needed as well.

Parameters	Default Value
Baud Rate	115200 bps
Data bits	8 bits
Parity	None
Stop bits	1 bit
Flow control	None

Control 3rd-party Device

Advanced users may need to control the 3rd-party device perform automated operations, such as automatically turning the projector on/off. MS0402-N011 provides "**RS232 automatic/manual control**".

RS232 automatic/manual control

RS232 control is performed by pre-stored instructions in the device. When the trigger condition is met, the configuration command is automatically sent out through the RS232 port.

Users can store the following instructions in settings:

- Display ON/OFF.
- Volume MUTE/UNMUTE.
- Volume UP/DOWN.

Users can set these instructions through the Web UI or API and turn on the **Auto-RS232** function to automatically execute, or perform these operations by manually sending APIs.

Auto-RS232 conditions:

- **Display ON:** When any active source is connected to the device.
- **Display OFF:** When all sources are disconnected from the device and after the "**Delay Time**" set.

Please refer to the "RS232" part in the "Web UI" section or separate document "API Command Set_MS0402-N011-000" to get detail command information.

TCP to RS232 routing

The TCP to RS232 routing function provides a tunnel from the network to the RS232 port, which can bypass the network control commands to the RS232 port. This function makes it easier for third-party devices such as a central-control device to control other devices connected to MS0402-N011.

TCP port number:

- **RS232-1**:5000;
- **RS232-2**:5001;
- **RS232-HDBT**: 5002.

LAN Control

Obtain the IP Address of the Device

The default IP mode of the MS0402-N011 device is: **DHCP**.

The user can obtain an IP address in the following ways:

1. Send API command via RS232-1 port.

Send API command "**GET IPADDR**<CR><LF>" to get the IP address, for example:

Input:

GET IPADDR<CR><LF>

Response:

IPADDR 172.16.18.173 MASK 255.255.255.0 GATEWAY 172.16.18.1

2. Use the tool "SmartSetGUI" to search the IP address.
3. Check the IP address in the DHCP server.

Telnet

Telnet port: 23.

Log in to the Web UI

The Web UI designed for this device allows for basic controls and settings. It can be accessed through a modern browser with latest version, e.g., Chrome, Safari, Firefox, IE10+, etc.

[To get access the Web UI:](#)

1. Connect one of the two ETHERNET ports of the device to a local area network. (Ensure there's a DHCP server in the network so that the device can obtain a valid IP address.)

Note: When VLAN is set to "Separate", please connect **ETHERNET-1** to the local area network for web UI control.

2. Connect the PC to the same network.
3. Input the device's IP address in the browser and press Enter, the following window will pop up. (Refer to [Obtain IP Address of the Device](#) section to get the device's IP address quickly).
4. The following window pops up. Input the password (default password: admin) and click "Login".



MS42 Switcher

Username

Password

Login

- Input a new password in the dialog box and click “Apply” to enter the main page. The password must be 4 to 16 characters long, alphanumeric, and include at least one uppercase letter, one lowercase letter, and one number.

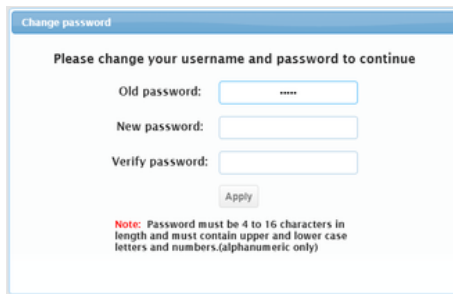

Change password

Please change your username and password to continue

Old password:

New password:

Verify password:

Note: Password must be 4 to 16 characters in length and must contain upper and lower case letters and numbers.(alphanumeric only)

Reset password and IP mode

If users forget the login password, the following ways can be used to restore the default password:

- Hold the “**RESET**” hole on the front panel for about 5s to reset the IP mode to DHCP and login password to “admin”.
- Hold the “**RESET**” hole on the front panel for about 15s to reset the device to factory defaults, which includes resetting the password.
- Send the API command “**RESET<CR><LF>**” to reset the device to factory defaults, which includes resetting the password.

Web UI

The main page consists of five tabs: Switch, General, Control, Network and System.

MS42 Switcher

Switch
AV Setting
Control
Network
System
Web: V1.1.2

Video & USB

OUT \ IN	IN 1 (HDMI)	IN 2 (HDMI)	IN 3 (USB-C)	IN 4 (USB-C)
VIDEO OUT 1				
VIDEO OUT 2				
ALL				

USB Mode: Follow VIDEO OUT 1 Apply

OUT \ IN	IN 1 (USB-B)	IN 2 (USB-B)	IN 3 (USB-C)	IN 4 (USB-C)
USB DEVICE				

Audio

FROM \ TO	USB HOST	AUDIO DE-EMBED (VIDEO OUT 1)	AUDIO DE-EMBED (VIDEO OUT 2)

Switch

1. Video& USB

Video & USB

OUT \ IN	IN 1 (HDMI)	IN 2 (HDMI)	IN 3 (USB-C)	IN 4 (USB-C)
VIDEO OUT 1				
VIDEO OUT 2				
ALL				

USB Mode: Follow VIDEO OUT 1 Apply

OUT \ IN	IN 1 (USB-B)	IN 2 (USB-B)	IN 3 (USB-C)	IN 4 (USB-C)
USB DEVICE				

This section allows users to switch video/USB input for output, and set USB mode.

- **VIDEO OUT 1/2:** Click the button in the table to switch one input source for VIDEO OUT 1 / VIDEO OUT 2 (button turns from white to green when the selection is done).
- **ALL:** Click to select one input for all Video outputs (button turns from white to green when the operation is done).
- **USB Mode:** Click to select USB-A devices switching mode (Follow VIDEO OUT 1, Follow VIDEO OUT 2, and Independently), and click "Apply" to take effect.

Default setting: Follow VIDEO OUT1, the USB-A devices switching follows the VIDEO OUT 1 switching. When set USB Mode to “Independent”, users can manually switch the USB host for the USB devices to be connected to by clicking the corresponding button in the table

USB Mode:

OUT \ IN	IN 1 (USB-B)	IN 2 (USB-B)	IN 3 (USB-C)	IN 4 (USB-C)
USB DEVICE				

2. Audio

Audio

FROM \ TO	USB HOST	AUDIO DE-EMBED (VIDEO OUT 1)	AUDIO DE-EMBED (VIDEO OUT 2)
AUDIO OUT / DANTE OUT			

Allow DANTE IN audio pass through to USB HOST ON OFF

Audio Mute

All:

HDMI OUT 1: HD8T OUT 2:

HDMI OUT 2: ANALOG OUT:

DANTE OUT:

This section allows users to switch audio input to output.

- **AUDIO OUT/DANTE OUT:** Three audio sources can be selected.
- Default Setting: AUDIO DE-EMBED (VIDEO OUT 1).
- **Allow DANTE IN audio pass-through to USB HOST:** Set whether enable DANTE IN audio to pass-through to USB HOST. Default setting: ON, the DANTE IN audio can be transmitted to the laptop the USB HOST port connected.
- **Audio Mute (ON/OFF):** Click to set the corresponding audio output to mute/unmute.
All: Click to set all audio to mute/unmute.
 Default Setting: Unmute.

3. USB MST

USB-C MST

USB-C IN 4 MST ON OFF

→ Only USB-C IN 4 support MST.
→ Enable the USB-C IN 4 MST function will occupy another input, which can be selected through the settings below.

Disabled USB-C IN 3 Input
 Disabled HDMI IN 2 Input

This section allows users to enable the **USB-C IN4 MST** function.

- **USB-C IN 4 MST:** Click to enable the MST function of USB-C IN 4 to ON/OFF. Default setting: OFF. When enabling this function, the USB-C IN 4 will occupy another input channel, check the box from the following inputs to set which input channel is occupied.

USB-C MST

USB-C IN 4 MST ON OFF

→ Only USB-C IN 4 support MST.
→ Enable the USB-C IN 4 MST function will occupy another input, which can be selected through the settings below.

Disabled USB-C IN 3 Input
 Disabled HDMI IN 2 Input

4. Auto-Switch

Auto-Switching

Auto-Switch ON OFF

LIFO Mode
→ Last in first out.

Priority Mode

Priority Setting

VIDEO OUT 1: USB-C IN 4 > USB-C IN 3 > HDMI IN 2 > HDMI IN 1

HDMI IN 1: <input type="text" value="4"/>	HDMI IN 2: <input type="text" value="3"/>	
USB-C IN 3: <input type="text" value="2"/>	USB-C IN 4: <input type="text" value="1"/>	<input type="button" value="Apply"/>

VIDEO OUT 2: USB-C IN 4 > USB-C IN 3 > HDMI IN 2 > HDMI IN 1

HDMI IN 1: <input type="text" value="4"/>	HDMI IN 2: <input type="text" value="3"/>	
USB-C IN 3: <input type="text" value="2"/>	USB-C IN 4: <input type="text" value="1"/>	<input type="button" value="Apply"/>

USB: USB-C IN 4 > USB-C IN 3 > HDMI IN 2 > HDMI IN 1

USB-B IN 1: <input type="text" value="4"/>	USB-B IN 2: <input type="text" value="3"/>	
USB-C IN 3: <input type="text" value="2"/>	USB-C IN 4: <input type="text" value="1"/>	<input type="button" value="Apply"/>

Note: 1 - Highest priority 4 - Lowest priority 0 - Ignored

This section allows users to set the auto-switch function to ON/OFF, and select auto-switching mode. Default: ON.

When the function is set to on, users can select auto switch mode between LIFO Mode and Priority Mode.

- **LIFO Mode (Default):** When inserting a new active input, all outputs will switch to this input automatically. When removing the current selected input, all outputs will switch to the previously active input.
- **Priority Mode:** When set to this mode, users can set input switching priority for **VIDEO OUT1, VIDEO OUT 2** and **USB** from each zone.

Note:

- "1" indicates the highest priority, "4" indicates the lowest priority, and "0" means this port will be ignored in automatic switching
- When two inputs are set to the same priority, will follow thesequence of priority is **USB IN 4 > HDMI IN 1 > USB IN 3 > HDMI IN 2.**
- When the USB Switch mode is set to follow video out 1/2, it will follow the corresponding video output to switch.
- When the USB Switch mode is set to independently, USB device switching also follows LIFO mode, and can set priority.

AV Setting

1. Down-Scaler

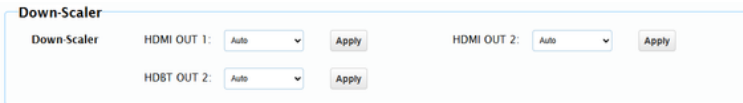

Down-Scaler

Down-Scaler

HDMI OUT 1: Auto Apply

HDMI OUT 2: Auto Apply

HDST OUT 2: Auto Apply

- This section allows users to set the down-scaler function for each output.
- **Down-Scaler:** Select the mode from the drop-down menu, and click "Apply" to take effect.
- **Auto (Default):** Automatically convert 4K resolution to 1080P when connected to a 1080P display.
- **Forced 1080P:** Forcely converts the input 4K resolution to 1080P regardless of the connected display's capabilities.
- **OFF:** Disabled down-scaler function.

2. EDID

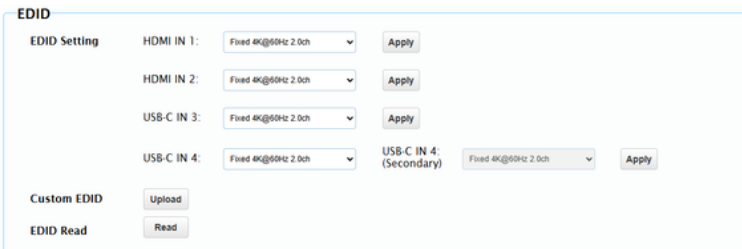

EDID

EDID Setting

HDMI IN 1: Fixed 4K@60Hz 2.0ch Apply

HDMI IN 2: Fixed 4K@60Hz 2.0ch Apply

USB-C IN 3: Fixed 4K@60Hz 2.0ch Apply

USB-C IN 4: Fixed 4K@60Hz 2.0ch

USB-C IN 4 (Secondary): Fixed 4K@60Hz 2.0ch Apply

Custom EDID: Upload

EDID Read: Read

This section allows users to set the EDID for each input and read the EDID of each output.

EDID Setting: Select EDID for the input port, and click “Apply” to take effect. The default setting for all inputs: Fixed 4K@60Hz 2.0ch.

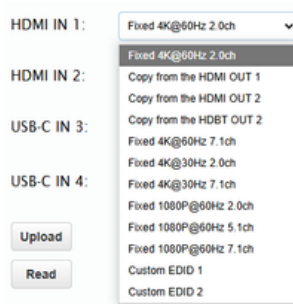

The screenshot shows a configuration interface with the following elements:

- HDMI IN 1:** Fixed 4K@60Hz 2.0ch
- HDMI IN 2:** Copy from the HDMI OUT 1
- USB-C IN 3:** Copy from the HDBT OUT 2
- USB-C IN 4:** Fixed 4K@30Hz 2.0ch

Buttons: Upload, Read

Dropdown menu options:

- Fixed 4K@60Hz 2.0ch
- Copy from the HDMI OUT 1
- Copy from the HDMI OUT 2
- Fixed 4K@60Hz 7.1ch
- Fixed 4K@30Hz 2.0ch
- Fixed 4K@30Hz 7.1ch
- Fixed 1080P@60Hz 2.0ch
- Fixed 1080P@60Hz 5.1ch
- Fixed 1080P@60Hz 7.1ch
- Custom EDID 1
- Custom EDID 2

- **Custom EDID:** Click “Upload” to enter the following page:

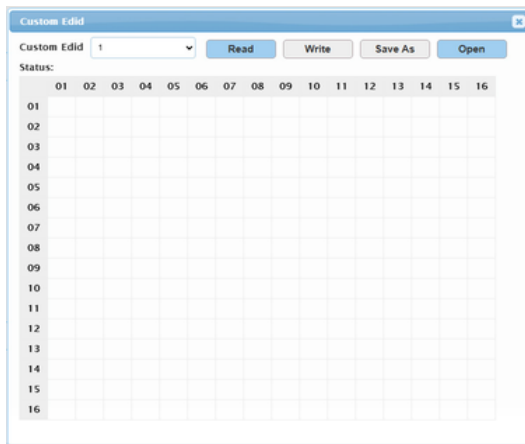

The screenshot shows the "Custom Edid" window with the following details:

- Window title: Custom Edid
- Custom Edid: 1
- Buttons: Read, Write, Save As, Open
- Status: Shows the status of reading selected customized EDID.
- Table with 16 columns (01-16) and 16 rows (01-16).

	01	02	03	04	05	06	07	08	09	10	11	12	13	14	15	16
01																
02																
03																
04																
05																
06																
07																
08																
09																
10																
11																
12																
13																
14																
15																
16																

- **Custom EDID:** Select a customized EDID from the drop-down menu (1 or 2).
- **Read:** Click to read the selected customized EDID. The result is shown on the table of the page.
- **Write:** Click to write the opened EDID to the selected customized EDID space.
- **Save As:** Click to save the customized EDID to the local PC.
- **Open:** Click to select an EDID bin file from the local PC.
- **Status:** Shows the status of reading selected customized EDID.

- **EDID Read:** Read the EDID of the output port and save it. Click “Read” button to enter the following page:

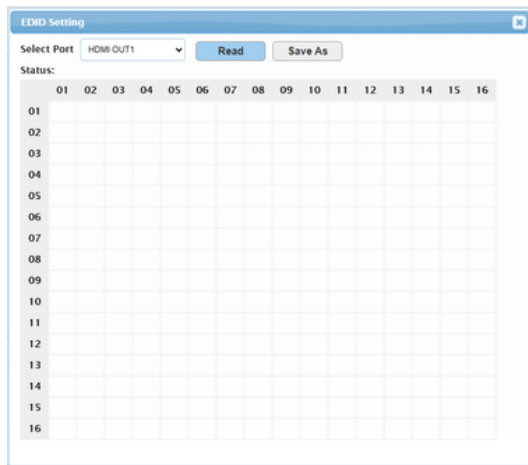

EDID Setting

Select Port: HDMI OUT1 [Read] [Save As]

Status:

	01	02	03	04	05	06	07	08	09	10	11	12	13	14	15	16
01																
02																
03																
04																
05																
06																
07																
08																
09																
10																
11																
12																
13																
14																
15																
16																

- **Select Port:** Select an output port from the drop-down menu.
- **Read:** Click to read the EDID of the selected output. The result is shown on the table of the page.
- **Save As:** Click to save the EDID as a bin file to the local PC.
- **Status:** Shows the status of reading EDID.

3. HDCP

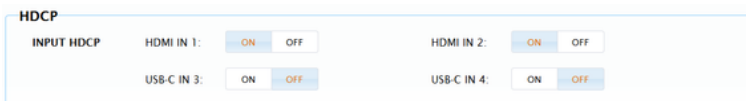

HDCP

INPUT HDCP: ON OFF

HDMI IN 1: ON OFF

HDMI IN 2: ON OFF

USB-C IN 3: ON OFF

USB-C IN 4: ON OFF

This section allows users to enable/disable the HDCP capability of inputs.

Default setting: HDMI IN 1/2: ON; USB-C IN 3/4: OFF.

Control

1. CEC

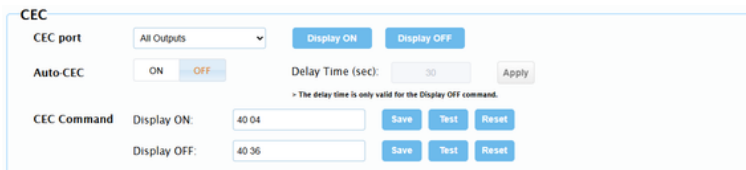

CEC

CEC port: All Outputs [Display ON] [Display OFF]

Auto-CEC: ON OFF Delay Time (sec): 30 [Apply]

-> The delay time is only valid for the Display OFF command.

CEC Command

Display ON: 40 04 [Save] [Test] [Reset]

Display OFF: 40 36 [Save] [Test] [Reset]

This section allows users to control the connected CEC-enabled displays to power on/off and set the Auto-CEC function.

- **CEC port:** Select the output port to control.
- **Display ON/OFF:** Click to control the corresponding CEC-enabled display to power on/off immediately.
- **Auto-CEC:** Enable/disable the auto-CEC function of the selected output. Default setting: OFF.
- **Delay Time:** Delay time for CEC "Display OFF" command. When the CEC display-off conditions are met, the command will not be issued until the set time arrives. Default setting: 30s. Range: 30s~1800s.
- **CEC Command:** Input the display on/off command to control the corresponding display.
 - **Save:** Click to save the input command.
 - **Test:** Click to send the input command test the input command.
 - **Reset:** Click to reset the command to default value.

Note: Please get the commands from the display's manufacturer, supplier or user manual.

2. RS232

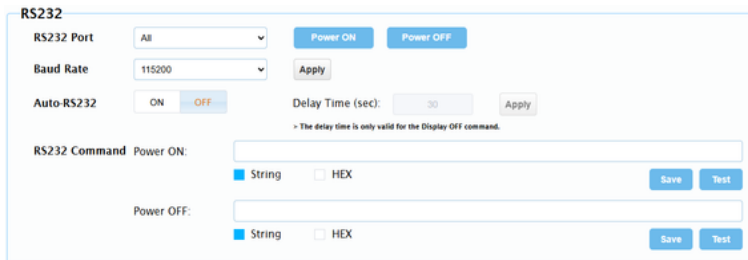

The screenshot shows the RS232 configuration interface. It includes a title 'RS232' and several control elements:

- RS232 Port:** A dropdown menu set to 'All' and two buttons: 'Power ON' and 'Power OFF'.
- Baud Rate:** A dropdown menu set to '115200' and an 'Apply' button.
- Auto-RS232:** Two radio buttons, 'ON' and 'OFF', with 'OFF' selected.
- Delay Time (sec):** A text input field containing '30' and an 'Apply' button. Below it is a note: '> The delay time is only valid for the Display OFF command.'
- RS232 Command:** Two sections, 'Power ON:' and 'Power OFF:'. Each has a text input field and radio buttons for 'String' (selected) and 'HEX'. 'Save' and 'Test' buttons are located to the right of each section.

This section allows users to set parameters for the RS232 port, set the **Auto-RS232** function and set the RS232 pre-stored command.

- **RS232 Port:** Select RS232 port to set from the drop-down menu.
- **Power ON/OFF:** Click to send the saved display on/off command to power on/off the 3rd device connected to the selected RS232 port.
- **Baud Rate:** Select the baud rate from the drop-down menu and click "Apply" to take effect.
- Default setting: 115200.
- **Auto-RS232:** Enable/disable the auto-RS232 function of the selected output.
- Default setting: OFF.
- **Delay Time:** Delay time for RS232 "Power OFF" command.
- When the RS232 display-off conditions are met, the command will not be issued until the set time arrives.
- Default setting: 30s. Range: 30s~1800s.

- **RS232 Command:** Input the Display ON/OFF commands for the 3rd party device in the corresponding field. The serial commands for displays and projectors are provided by their manufacturer and can be found in the instructional documentation.
- **String/HEX:** If the command for display on/off is only available in Hex format, check the “HEX” button and input the Hex command in the field, otherwise, check the “String” button.
- **Save:** Click to save the input command to the matrix.
- **Test:** Click to send the input command to the 3rd device directly to test it.
- **Note:** The RS232 command must be set before use, otherwise the RS232 port will not send anything.

3. RELAY

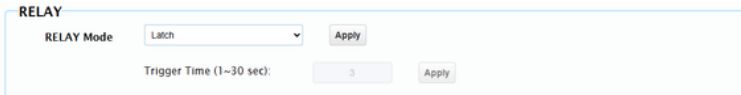

This section allows users to configure the RELAY.

- **RELAY Mode:** Select relay mode from the drop-down menu (Latch or Momentary), and click “Apply” to take effect.
- Default setting: Latch.
- **Latch:** Level mode.
- **Momentary:** Pulse mode.
- **Trigger Time:** When setting relay mode to momentary, input the trigger time in this field, and click “Apply” to take effect. Default setting: 3s. Range: 1s~30s.

4. SENSOR

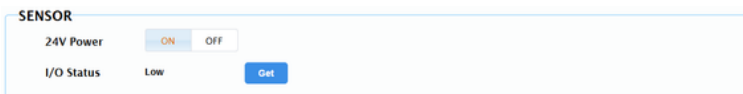

This section allows users to set 24V output voltage of the sensor to on/off and get I/O status.

- **24V Power:** Enabled/disable the 24V power out for the sensor port.
- **I/O Status:** Click “Get” to get the current I/O status of the sensor port.

5. USB Device

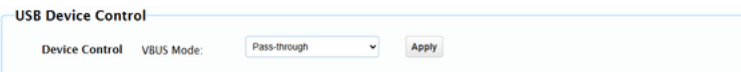

This section allows users to set VBUS mode for USB device ports.

- **VBUS Mode:** Select VBUS mode.

- **Pass-through (default):** If the selected USB Host is not connected, all USB device ports will have no VBUS output.
- **Always High:** The USB device ports always provide VBUS output.

6. GPIO

GPIO

GPIO: All

GPIO Setting

I/O: Output Apply

Pull-up Resistor: Connected Apply

State: High Apply

GPIO Status:

GPIO 1:	Input - Low	GPIO 2:	Input - Low
GPIO 3:	Input - Low	GPIO 4:	Input - Low

- This section allows users to configure GPIO.
- **GPIO:** Select the GPIO port from the drop-down menu to configure.
- **GPIO Settings:**
- **I/O:** Select the GPIO type between “Output” and “Input”, and click “Apply” to take effect.

When select "Output":

- **Pull-up Resistor:** Enable/disable the Pull-up Resistor.
- **State:** Set GPIO output state to “High” or “Low”.

When select "Input":

GPIO

GPIO: All

GPIO Setting

I/O: Input Apply

GPIO Status:

GPIO 1:	Input - Low	GPIO 2:	Input - Low
GPIO 3:	Input - Low	GPIO 4:	Input - Low

- **GPIO Status:** Shows the current GPIO type and status.

Network

1. Network Setting

Network Setting

IP Type: Static DHCP

IP Address: 192.168.1.117

Subnet Mask: 255.255.240.0

Default Gateway: 192.168.2.1 Apply

Note: After changing network configuration, please reopen the web page with the new network settings.

The network is used to set the IP mode.

Note:

- When "Static" is selected, please ensure your PC is in the same network segment as the Matrix.
- Please wait for 2-3 minutes for the LAN module to reboot and reconnect after the network setting is changed.

2. Service Capability

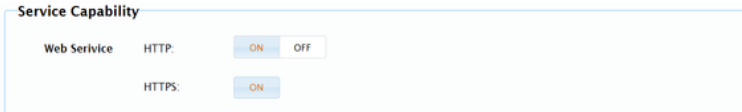

The screenshot shows the 'Service Capability' section with two rows of toggle switches. The first row is for 'Web Service HTTP' with 'ON' selected and 'OFF' unselected. The second row is for 'HTTPS' with 'ON' selected.

This section allows users to set HTTP and HTTPS.

- **HTTP:** Enable/disable the HTTP connection. Default Setting: ON.
- **HTTPS:** HTTPS is supported and CAN NOT disabled.

3. USB to Ethernet Bridge

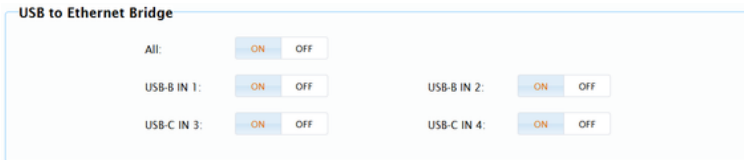

The screenshot shows the 'USB to Ethernet Bridge' section with five rows of toggle switches. The first row is 'All' with 'ON' selected. The second row is 'USB-B IN 1' with 'ON' selected. The third row is 'USB-C IN 3' with 'ON' selected. The fourth row is 'USB-B IN 2' with 'ON' selected. The fifth row is 'USB-C IN 4' with 'ON' selected.

USB Bridge refers to the USB Network Card.

The device provides four USB network cards on USB-C and USB-B ports. This section allows users to enable/disable the USB bridge function for each port. Default setting: On. When it is set to on, the device connected to the USB-B 1/2 or USB-C 3/4 can access to the network the ETHERNET ports connected.

4. VLAN



The screenshot shows the 'VLAN Mode' section with a dropdown menu set to 'Transparent' and an 'Apply' button. Below the dropdown, there are two lines of small text: '-> Transparent: Network interconnection of all devices.' and '-> Separated: The secure network port (Ethernet 1) is only used to log in to the Web UI. Other networks are connected to Ethernet 2.'

VLAN settings can help administrators isolate the internal network and the guest network to protect the network security.

The device provides **TWO** Ethernet ports, which can be used for VLAN settings.

- **VLAN Mode:** Select VLAN mode from the drop-down menu, and click "Apply" to take effect.
- **Transparent:** Network interconnection of all devices.

VLAN Setting -- Transparent

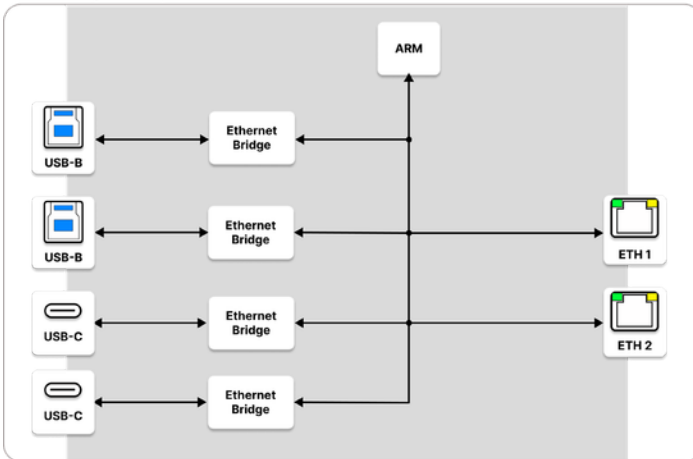

- **Separated:** Isolate the device network from the USBNIC network. Only the secure network port, **Ethernet 1**, can access the device's Web UI. Other USB NIC devices are connected to **Ethernet 2**.

VLAN Setting -- Separated

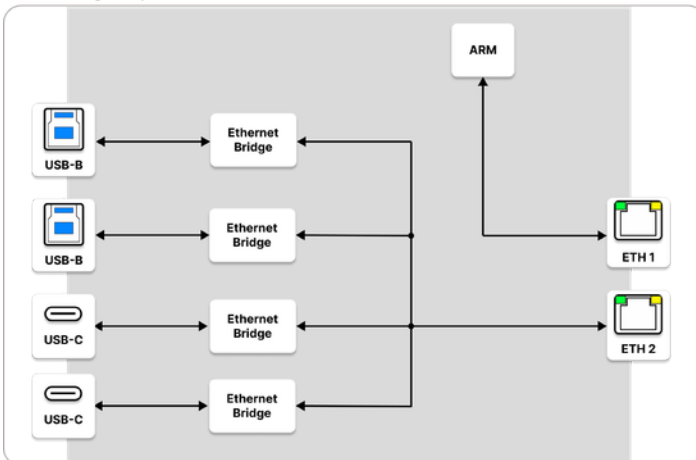

5. 802.1x

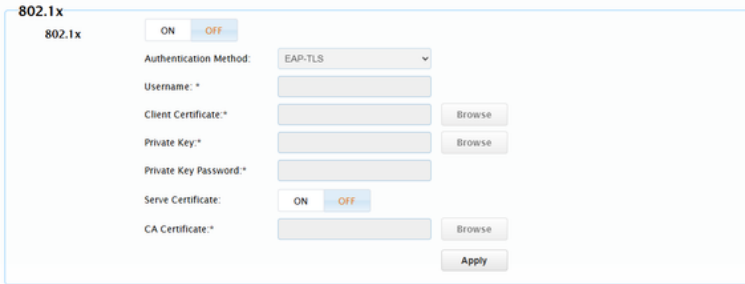

802.1x

802.1x ON OFF

Authentication Method: EAP-TLS

Username: *

Client Certificate:*

Private Key:*

Private Key Password:*

Serve Certificate: ON OFF

CA Certificate:*

Browse

Browse

Browse

Browse

Apply

- **802.1x:** Click to enable/disable 802.1x Authentication service. The device supports "EAP-TLS" and "EAP-MSCHAP V2" two mode. Default setting: OFF.

When set 802.1x to ON:

802.1x supports authentication based on port and MAC address.

The two following authentication methods are offered:

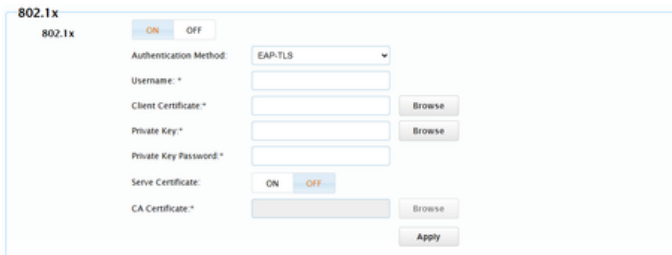

802.1x

802.1x ON OFF

Authentication Method: EAP-TLS

Username: *

Client Certificate:*

Private Key:*

Private Key Password:*

Serve Certificate: ON OFF

CA Certificate:*

Browse

Browse

Browse

Browse

Apply

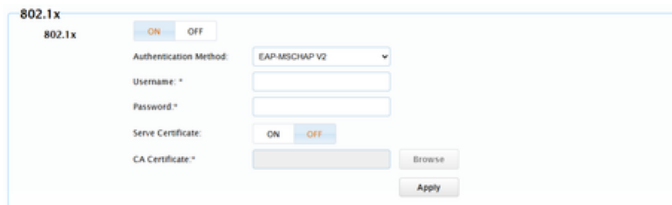

802.1x

802.1x ON OFF

Authentication Method: EAP-MSCHAP V2

Username: *

Password:*

Serve Certificate: ON OFF

CA Certificate:*

Browse

Apply

- **EAP-TLS:** This method requires to submit username,CA certificate, Client Certificate, private key and privatekey password for authentication.
- Username require alphanumeric, "-", "_" and characters within length of 1 to 24 characters, "-" and "_" cannot be at beginning or end.
- Private Key Password require printable ASCII characters within length of 1 to 24 characters.

- **EAP-MSCHAP V2:** This method requires to submit username and password for authentication.
- Username require alphanumeric, "-", "_" and characters within length of 1 to 24 characters, "-" and "_" cannot be at the beginning or end.
- Password require printable ASCII characters within length of 1 to 24 characters.
- **Server Certificate:** Click to set server certificate to on/off. Default setting: OFF.
- When it is set to on, users need to submit a CA certificate for authentication.
- **Apply:** Click to perform above settings and reboot the device.

System

1. Login Password

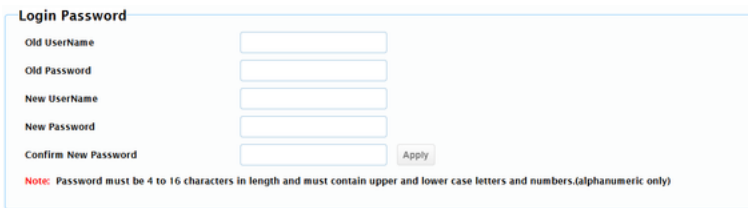

Login Password

Old UserName

Old Password

New UserName

New Password

Confirm New Password

Note: Password must be 4 to 16 characters in length and must contain upper and lower case letters and numbers.(alphanumeric only)

Default Username&Password: "admin"

Note: The password must be 4 to 16 characters long, alphanumeric, and include at least one uppercase letter, one lowercase letter, and one number.

2. FW Update



FW Update

File:

- Click "Browse" to select the update file from local PC.



FW Update

File:

- Click "Upgrade" to start the upgrading.

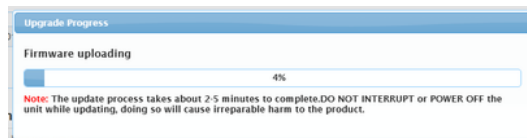

Upgrade Progress

Firmware uploading

Note: The update process takes about 2-5 minutes to complete.DO NOT INTERRUPT or POWER OFF the unit while updating, doing so will cause irreparable harm to the product.

- When the upgrade is success, the following windowpops up. Click "OK" and refresh the web page to re-login web UI.

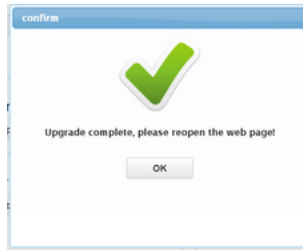

Note: DO NOT power off the device during the updating process.

3. Configuration Import and Export

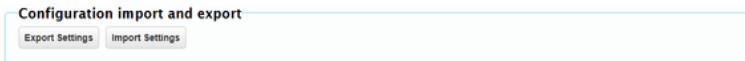

- **Export Settings:** Click to export the settings file to the local PC.
- **Import Settings:** Click to import the settings file from the local PC and apply the imported settings.

4. Restore Factory

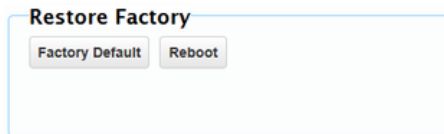

- **Factory Default:** Click to set the device to factory defaults.
- **Reboot:** Click to reboot the device.

5. Version

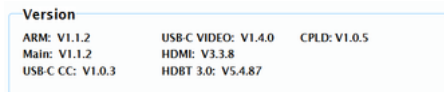

This section shows the device's firmware version information.

6. Log

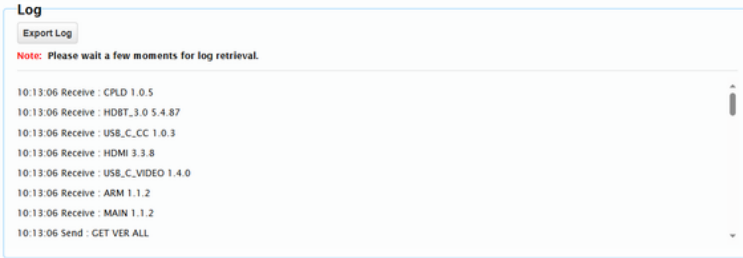

This section displays system setting change records.

Export Log: Click to download the log file to the local PC.

Note: Please wait for a few moments for log retrieval.

Dante Introduction

The MS0402-N011 supports a 2x2 Dante audio transmission. Before using the Dante function, please:

1. Connect all Dante devices to the same network.
2. Use "**Dante Controller**" to pair Dante devices.
(<https://www.audinate.com/products/software/dante-controller>)

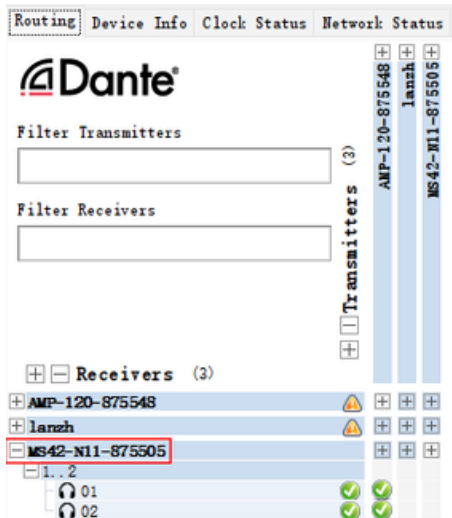

Note: Some network switches may cause "**Dante controller**" to be unable to recognize Dante devices. Please replace the switch.