

**H180 Top Pivot**

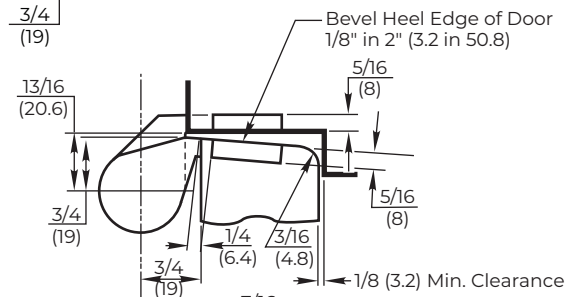

**M-190 Side Jamb Pivot**  
(Minimum of Two (2) Required)

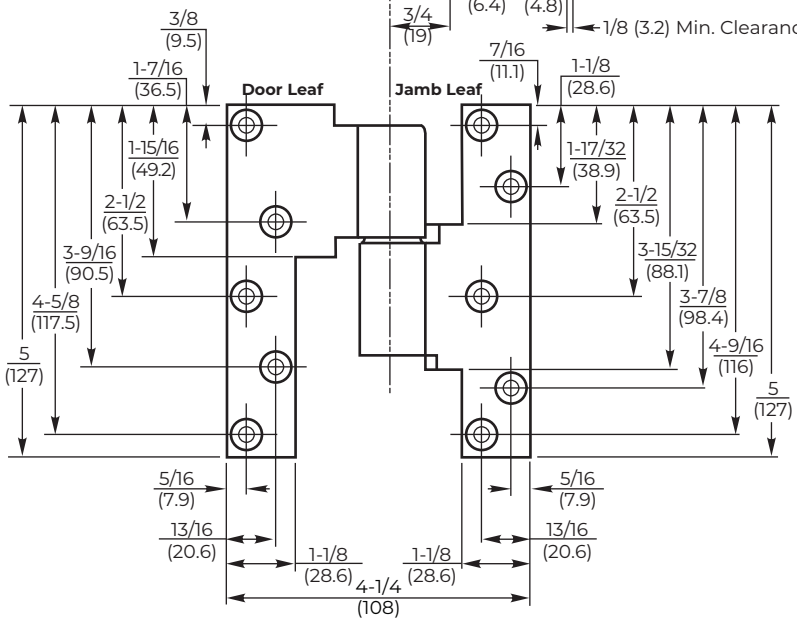

**165 Pivot Set**  
**3/4" Offset**

**NOTES:**

1. Do not scale drawing.
2. Right hand shown.
3. Top and side jamb pivots are drilled for 1/4-20 x 5/8" FHMS or #14 x 1-1/2" FHWS.
4. Revision History

Rev 1 - Document ccreation



TEMPLATE NUMBER	REV	DATE
IS-165	4	12/25