

# SEC 25 & 27 Security Floor Closer

## 3/4" Offset Pivoted - Handed 180 Top Pivot - Non Handed Installation Instructions

### **! WARNING**

This product can expose you to lead which is known to the state of California to cause cancer and birth defects or other reproductive harm. For more information go to [www.P65warnings.ca.gov](http://www.P65warnings.ca.gov).

### **Note:**

1. Do not scale drawing.
2. Right hand shown.
3. If vertical adjustment is required two 1/16" shims are provided. Place shims between arm and arm bearing washer.
4. Furnished for doors set back 1/16". For other door conditions specify set back.
5. All dimensions given in inches. Metric = inch x 25.4.

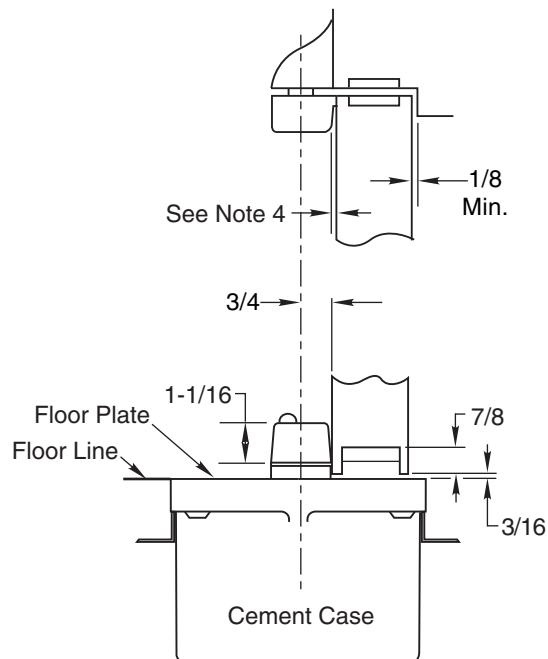
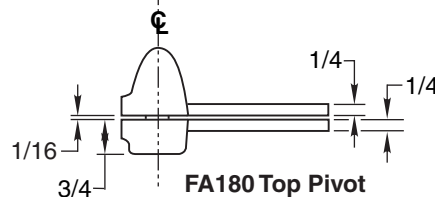
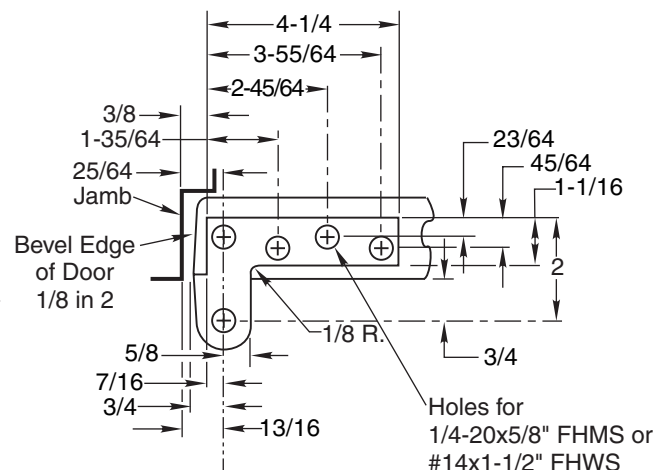
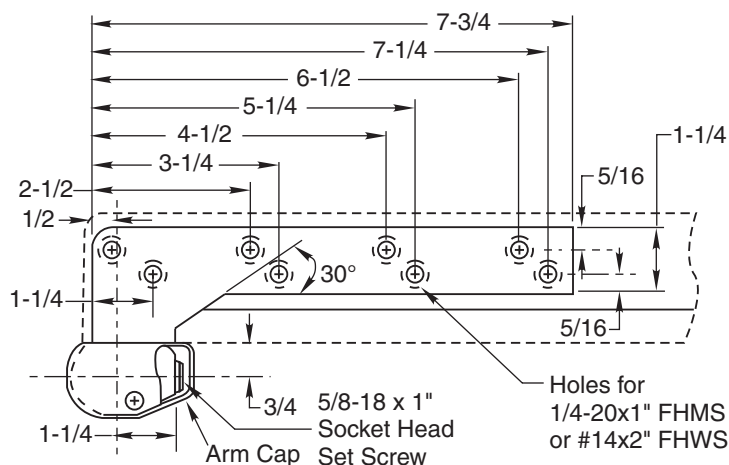
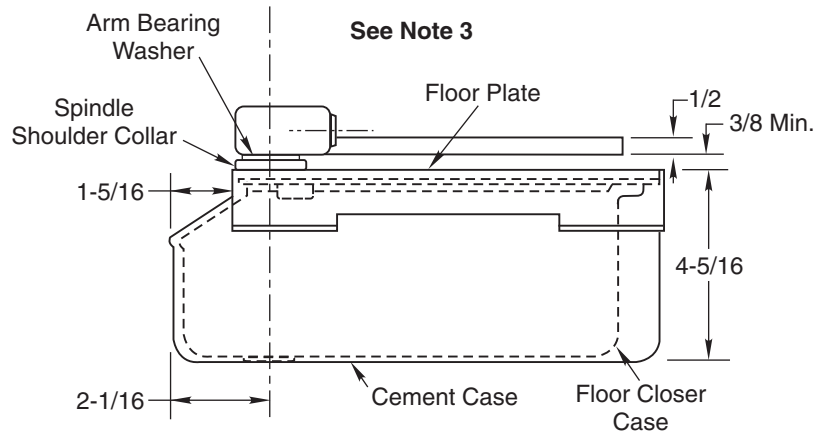
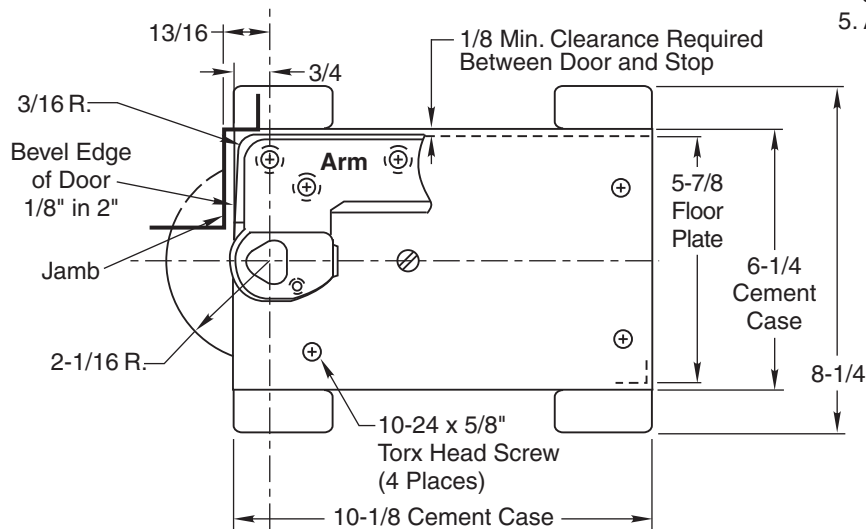

**How To Determine  
Hand of Door**

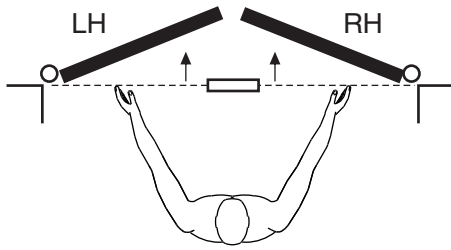

Face a door swinging open away from you. If it opens to the right, it is right hand. If it opens to the left, it is left hand.

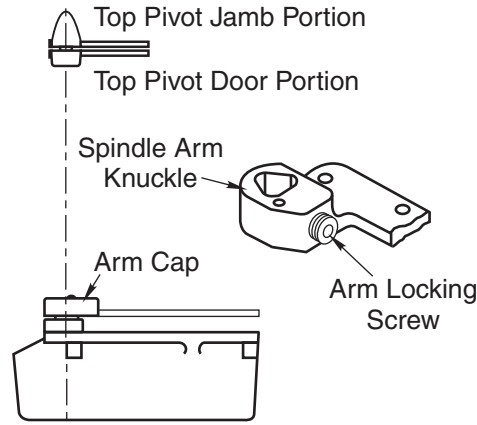

**RIGHT HAND installation**

**IMPORTANT:**

Use plumb line to make sure that center line of top pivot pin lines up with center line of closer spindle.

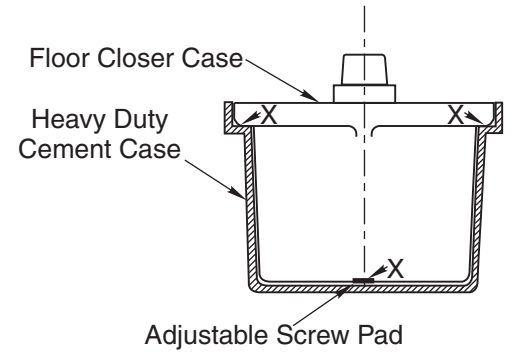

**CAUTION:**

An adjustable screw pad is provided in this heavy duty cement case for better load distribution. This pad is adjusted so the heavy duty closer case is equally supported by the adjustable pad and the case flange pads at outer corners of case as shown by "X". Pad is staked to keep from coming loose.

**1. Locating Closer**

For accurate installation see your dealer for a 185 Quickspotter Kit.

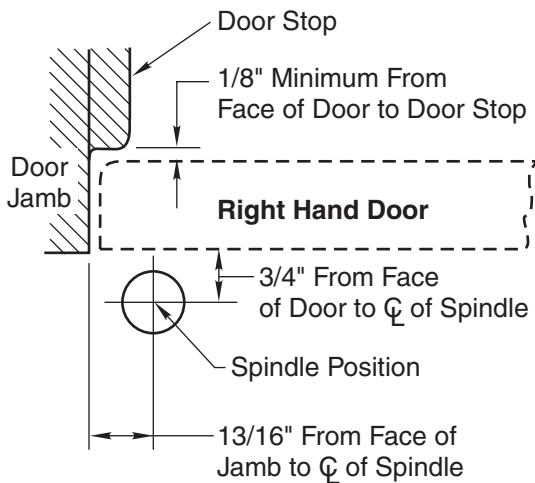

- A. Measure 13/16" out from door jamb.
- B. Allow 1/8" minimum clearance from door stop to door face. Measure door thickness. Add 3/4".
- C. Where lines meet determines center line of closer.

**2. Install Cement Case in Floor**

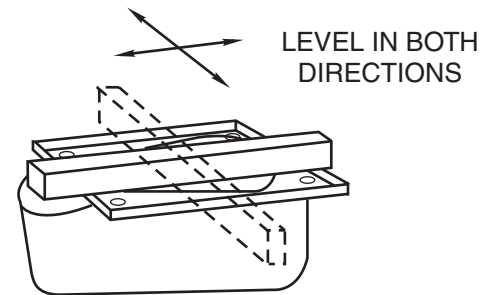

- A. For floor plate application: Cement case is set 1/8" (3.2mm) below floor level.
- B. For threshold application: Cement case is set flush with floor.
- C. Set cement case in floor and block in position.
- D. Case should be parallel with center line of door.
- E. **CEMENT CASE SHOULD BE LEVEL.** Place levels per illustration.
- F. Grout in cement case with closer. Cement should not get between closer and case.

**3. Install Top Pivot & Closer Arm**

- A. Install top pivot in door per template.
- B. Install top pivot in frame per template.
- C. Center line of pivot should line up with center line of closer. Use plumb line as illustrated.
- D. If side pivot is used, see template for intermediate pivot.
- E. Install door closer arm in bottom of door per template.

## 4. Hang Door

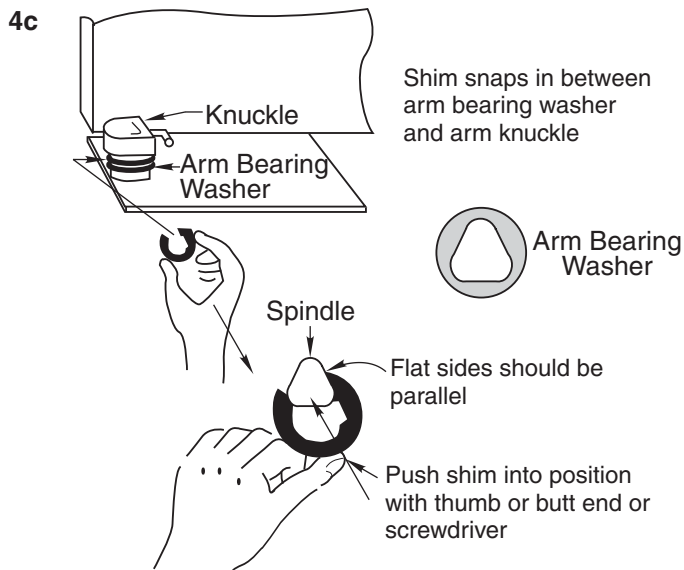
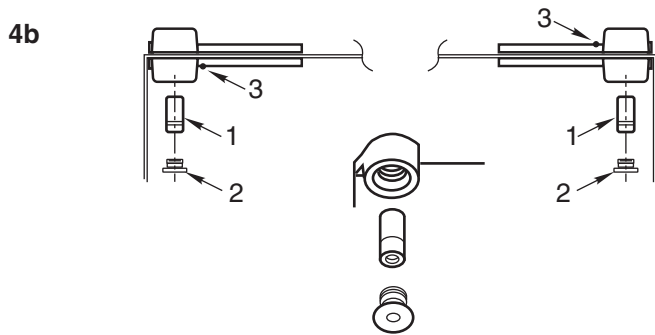
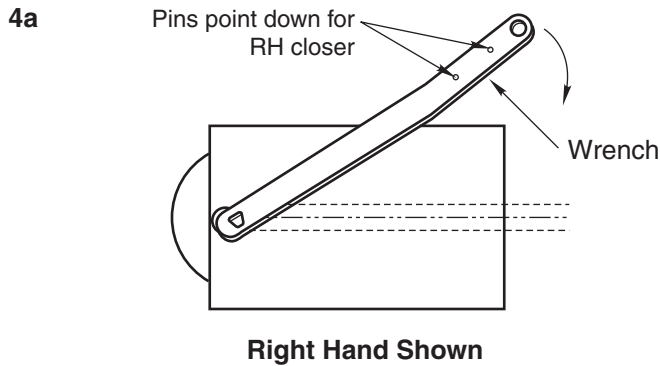

- CAUTION:** Closer is shipped with Closing Speed valve down. **DO NOT FORCE VALVE DOWN.**
- Using wrench, turn spindle until wrench is parallel with center line of closer. (Illustration 4a)
  - Insert arm bearing washer over spindle then set door on closer spindle. **DO NOT FORCE DOOR CLOSED WHILE "CLOSING SPEED" VALVE IS TURNED DOWN.**  
NOTE: You may have received two different styles of top pivots. Check the pivot pins. If the pivot pin has an O-ring, see instruction C. If no O-ring, see instruction D.
  - Push item 1 "top pivot pin" into place. NOTE: Key on pin **MUST ALIGN WITH KEYWAY**. Keyway is towards face of door. Slot in pin is parallel to face of door. Attach "cap" item 2. (Illustration 4b) **CAP MUST BE TIGHTENED SECURELY.**
  - Close door to 60° or more and turn valve screw counterclockwise. Door will then close.
  - Open "closing speed" valve (counterclockwise) one turn.
  - If door drags at floor (or threshold, if used), raise door to desired clearance and insert one or more 1/16" shims. (Illustration 4c)
  - While working door back and forth **TIGHTEN ARM LOCKING SCREW SECURELY** with wrench furnished.
  - Put arm cap on closer spindle and secure **TIGHTLY** with cap screw furnished.

The ASSA ABLOY Group is the global leader in access solutions. Every day we help people feel safe, secure and experience a more open world.

## Closer Adjustment

### SEC25

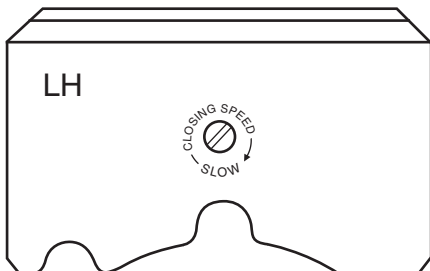

Closing speeds can be adjusted to suit local conditions and requirements. With a screw driver turn the adjustment screw that projects through the floor plate or threshold, either in or out as the case may be until the desired action is attained. Turn this valve

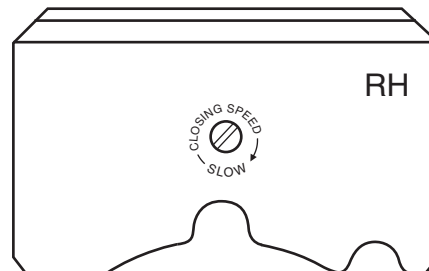

screw to the right, clockwise, to decrease closing speed and to the left to increase the closing speed. **FORCING THIS SCREW DOWN WILL IMPAIR ITS OPERATION.** Important: Spindle centerline must be maintained.

### SEC27

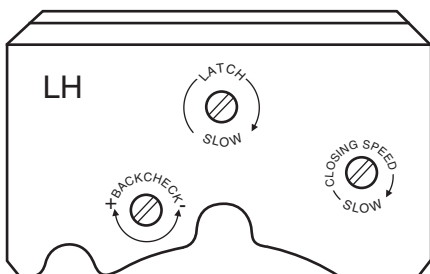

Closing speeds can be adjusted to suit local conditions and requirements. Label on closer face designates the purpose of each adjustment screw. Adjustments are for speed control.

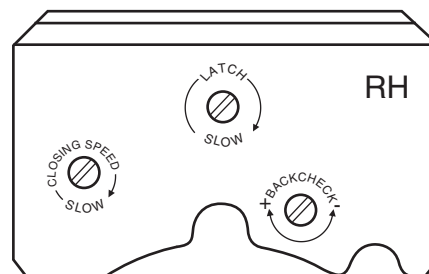

- A. The Closing Speed valve allows adjustment from full open to 15°.
- B. The Closing Speed valve allows adjustment from 65° to 15° closed position.
- C. Latch valve allows adjustment from 15° to closed position.
- D. Important: Backcheck adjustment must be adjusted to vary resistance from light to firm at 60° of door open. Do not use Backcheck as deadstop. This is an intensity valve not speed control.

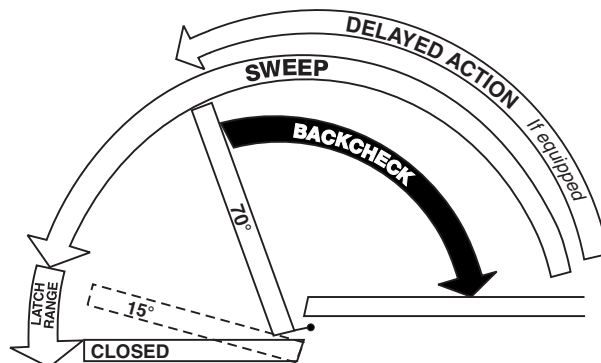

## Spring Power Adjustments

This closer can be adjusted for increased or decreased spring power.

These adjustments if required should be done by an authorized repair agency.

Repairs, parts replacement or internal adjustments must be done by a Norton Rixson authorized repair agency. Consult [NortonRixson.com](http://NortonRixson.com) for an authorized repair agency in your area.

Technical Product Support:  
Monroe, NC 28112 USA  
Phone: 800.438.1951 ext: 6030  
[Techsupport.NortonRixson@assaabloy.com](mailto:Techsupport.NortonRixson@assaabloy.com)  
[NortonRixson.com](http://NortonRixson.com)